

**V600 RFID System**  
**V600-CM1D**

# **Board Type ID Controller**

## **OPERATION MANUAL**

**OMRON**

## **Notice:**

OMRON products are manufactured for use according to proper procedures by a qualified operator and only for the purposes described in this manual.

The following conventions are used to indicate and classify precautions in this manual. Always heed the information provided with them. Failure to heed precautions can result in injury to people or damage to property.

## **OMRON Product References**

All OMRON products are capitalized in this manual. The word "Unit" is also capitalized when it refers to an OMRON product, regardless of whether or not it appears in the proper name of the product.

The abbreviation "Ch," which appears in some displays and on some OMRON products, often means "word" and is abbreviated "Wd" in documentation in this sense.

The abbreviation "PLC" means Programmable Controller. "PC" is used, however, in some Programming Device displays to mean Programmable Controller.

## **Visual Aids**

The following headings appear in the left column of the manual to help you locate different types of information.

**Note** Indicates information of particular interest for efficient and convenient operation of the product.

**1,2,3...** 1. Indicates lists of one sort or another, such as procedures, checklists, etc.

## **© OMRON, 2003**

All rights reserved. No part of this publication may be reproduced, stored in a retrieval system, or transmitted, in any form, or by any means, mechanical, electronic, photocopying, recording, or otherwise, without the prior written permission of OMRON.

No patent liability is assumed with respect to the use of the information contained herein. Moreover, because OMRON is constantly striving to improve its high-quality products, the information contained in this manual is subject to change without notice. Every precaution has been taken in the preparation of this manual. Nevertheless, OMRON assumes no responsibility for errors or omissions. Neither is any liability assumed for damages resulting from the use of the information contained in this publication.

## Read and Understand this Catalog

Please read and understand this catalog before purchasing the product. Please consult your OMRON representative if you have any questions or comments.

## Warranty and Limitations of Liability

### WARRANTY

OMRON's exclusive warranty is that the products are free from defects in materials and workmanship for a period of one year (or other period if specified) from date of sale by OMRON.

OMRON MAKES NO WARRANTY OR REPRESENTATION, EXPRESS OR IMPLIED, REGARDING NON-INFRINGEMENT, MERCHANTABILITY, OR FITNESS FOR PARTICULAR PURPOSE OF THE PRODUCTS. ANY BUYER OR USER ACKNOWLEDGES THAT THE BUYER OR USER ALONE HAS DETERMINED THAT THE PRODUCTS WILL SUITABLY MEET THE REQUIREMENTS OF THEIR INTENDED USE. OMRON DISCLAIMS ALL OTHER WARRANTIES, EXPRESS OR IMPLIED.

### LIMITATIONS OF LIABILITY

OMRON SHALL NOT BE RESPONSIBLE FOR SPECIAL, INDIRECT, OR CONSEQUENTIAL DAMAGES, LOSS OF PROFITS OR COMMERCIAL LOSS IN ANY WAY CONNECTED WITH THE PRODUCTS, WHETHER SUCH CLAIM IS BASED ON CONTRACT, WARRANTY, NEGLIGENCE, OR STRICT LIABILITY.

In no event shall the responsibility of OMRON for any act exceed the individual price of the product on which liability is asserted.

IN NO EVENT SHALL OMRON BE RESPONSIBLE FOR WARRANTY, REPAIR, OR OTHER CLAIMS REGARDING THE PRODUCTS UNLESS OMRON'S ANALYSIS CONFIRMS THAT THE PRODUCTS WERE PROPERLY HANDLED, STORED, INSTALLED, AND MAINTAINED AND NOT SUBJECT TO CONTAMINATION, ABUSE, MISUSE, OR INAPPROPRIATE MODIFICATION OR REPAIR.

## Application Considerations

### SUITABILITY FOR USE

OMRON shall not be responsible for conformity with any standards, codes, or regulations that apply to the combination of products in the customer's application or use of the products.

At the customer's request, OMRON will provide applicable third party certification documents identifying ratings and limitations of use that apply to the products. This information by itself is not sufficient for a complete determination of the suitability of the products in combination with the end product, machine, system, or other application or use.

The following are some examples of applications for which particular attention must be given. This is not intended to be an exhaustive list of all possible uses of the products, nor is it intended to imply that the uses listed may be suitable for the products.

- Outdoor use, uses involving potential chemical contamination or electrical interference, or conditions or uses not described in this catalog.
- Nuclear energy control systems, combustion systems, railroad systems, aviation systems, medical equipment, amusement machines, vehicles, safety equipment, and installations subject to separate industry or government regulations.
- Systems, machines, and equipment that could present a risk to life or property.

Please know and observe all prohibitions of use applicable to the products.

NEVER USE THE PRODUCTS FOR AN APPLICATION INVOLVING SERIOUS RISK TO LIFE OR PROPERTY WITHOUT ENSURING THAT THE SYSTEM AS A WHOLE HAS BEEN DESIGNED TO ADDRESS THE RISKS, AND THAT THE OMRON PRODUCTS ARE PROPERLY RATED AND INSTALLED FOR THE INTENDED USE WITHIN THE OVERALL EQUIPMENT OR SYSTEM.

## Disclaimers

### CHANGE IN SPECIFICATIONS

Product specifications and accessories may be changed at any time based on improvements and other reasons.

It is our practice to change model numbers when published ratings or features are changed, or when significant construction changes are made. However, some specifications of the products may be changed without any notice. When in doubt, special model numbers may be assigned to fix or establish key specifications for your application on your request. Please consult with your OMRON representative at any time to confirm actual specifications of purchased products.

### DIMENSIONS AND WEIGHTS

Dimensions and weights are nominal and are not to be used for manufacturing purposes, even when tolerances are shown.

### ERRORS AND OMISSIONS

The information in this catalog has been carefully checked and is believed to be accurate; however, no responsibility is assumed for clerical, typographical, or proofreading errors, or omissions.

## Meanings of Signal Words

The following signal words are used in this operation manual.

### **WARNING**

Indicates a potentially hazardous situation which, if not avoided, will result in minor or moderate injury, or may result in serious injury or death. Additionally there may be significant property damage.

## Meanings of Alert Symbols

The following alert symbols are used in this operation manual.



Indicates the possibility of explosion under specific conditions.

## Alert Statements in this Instruction Manual

The following alert statements apply to the products in this instruction manual. Each alert statement also appears at the locations needed in the manual to attract your attention.

### **WARNING**

The SRAM-type Data Carrier has a built-in lithium battery which can combust or explode if mishandled. Do not disassemble the Data Carrier, or subject it to high pressure or high temperatures (of 100°C or more), or dispose of it by incineration.



# TABLE OF CONTENTS

## SECTION 1

<b>Features and System Configuration</b> .....	<b>1</b>
1-1 Features .....	2
1-2 System Configuration .....	3
1-3 Outline of Operation .....	4
1-4 User I/O .....	5

## SECTION 2

<b>Nomenclature and Specifications</b> .....	<b>7</b>
2-1 Names and Functions of Parts .....	8
2-2 Specifications and Characteristics .....	10
2-3 I/O Specifications .....	10
2-4 Communications Specifications .....	12
2-5 Outline Size .....	13

## SECTION 3

<b>Switch Setting and Wiring</b> .....	<b>15</b>
3-1 DIP Switch Setting .....	16
3-2 Installation Environment .....	19
3-3 Wiring .....	19
3-4 RS-232C Interface Connection .....	20

## SECTION 4

<b>Communications</b> .....	<b>21</b>
4-1 Movement of Data Carrier and Command Status .....	22
4-2 Memory Map of Data Carrier .....	26
4-3 Command Format .....	30
4-4 Types of Commands and Responses .....	34
4-5 Example of Communications Program .....	46
4-6 Communication Time .....	47

## SECTION 5

<b>Testing</b> .....	<b>51</b>
5-1 Test Run .....	52
5-2 Diagnostics .....	53
5-3 Error Lists .....	54
5-4 Checking the Data Carrier Life .....	55
5-5 Checking Function of the Data Carrier's Memory .....	59
5-6 Troubleshooting .....	62
5-7 Maintenance and Inspection .....	63
5-8 Systems Check .....	64

<b>Index</b> .....	<b>69</b>
--------------------	-----------

<b>Revision History</b> .....	<b>73</b>
-------------------------------	-----------

## ***About this Manual:***

This manual describes the operation of the V600 RFID System and includes the sections described below.

Please read this manual completely and be sure you understand the information provided before attempting to operate the system.

**Section 1** provides a general introduction to the RFID System and the ID Controller.

**Section 2** provides the names and functions of the ID Controller parts and also provides the ID Controller's specifications.

**Section 3** provides the DIP switch settings and the wiring instructions required before operating the ID Controller.

**Section 4** provides information on the communications aspects of the RFID System.

**Section 5** provides the information required to test and maintain the performance of the RFID System.



**WARNING** Failure to read and understand the information provided in this manual may result in personal injury or death, damage to the product, or product failure. Please read each section in its entirety and be sure you understand the information provided in the section and related sections before attempting any of the procedures or operations given.

# SECTION 1

## Features and System Configuration

This section provides a general introduction to the RFID System and the ID Controller.

1-1	Features .....	2
1-2	System Configuration .....	3
1-3	Outline of Operation .....	4
1-4	User I/O .....	5

## 1-1 Features

V600 RFID System offers powerful support to the automation of large-scale distributed control systems and multi-model small-scale production systems by means of contactless data communication.

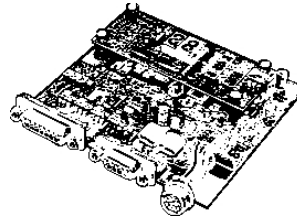

### Easy to Use

- Significantly shortens the communication tact time with moving pallets.
- A RS-232C interface that can be connected to a general-purpose factory computer or personal computer is provided. Using simple commands, a large quantity of data can be processed easily.
- Board type allows for flexible mounting.
- Up to 2 KBytes of data can be read/written by batch commands, thus shortening the work processing time.
- The write command repeat function simplifies data transmission between the ID Controller and host controller.
- Two user inputs and two user outputs that can be manipulated by commands help reduce system organization costs.
- Command end codes are displayed on-screen for checking operating status and facilitating system maintenance.
- Records up to 30 errors which may occur during operation for the quick investigation into causes of system abnormalities.
- Testing communications with a Data Carrier (DC) can be performed off-line. This facilitates installation of the Read/Write (R/W) Head and DC when organizing the system.



## 1-2 System Configuration

Being equipped with a serial interface conforming to RS-232C, the ID Controller V600-CM1D can communicate with general-purpose factory computers (FC) and personal computers (IBM XT/AT compatible). Communications processing is performed using the commands from a host computer (FC, IBM XT/AT compatible) in the RUN mode.

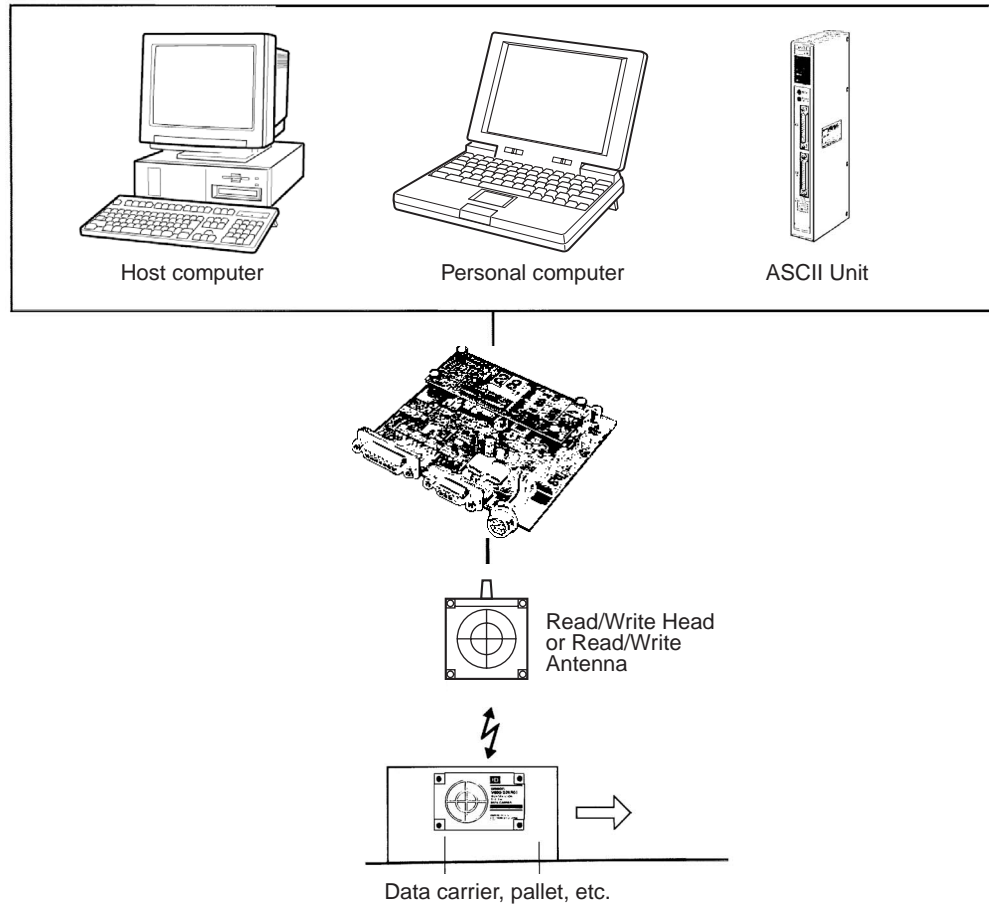

### 1-3 Outline of Operation

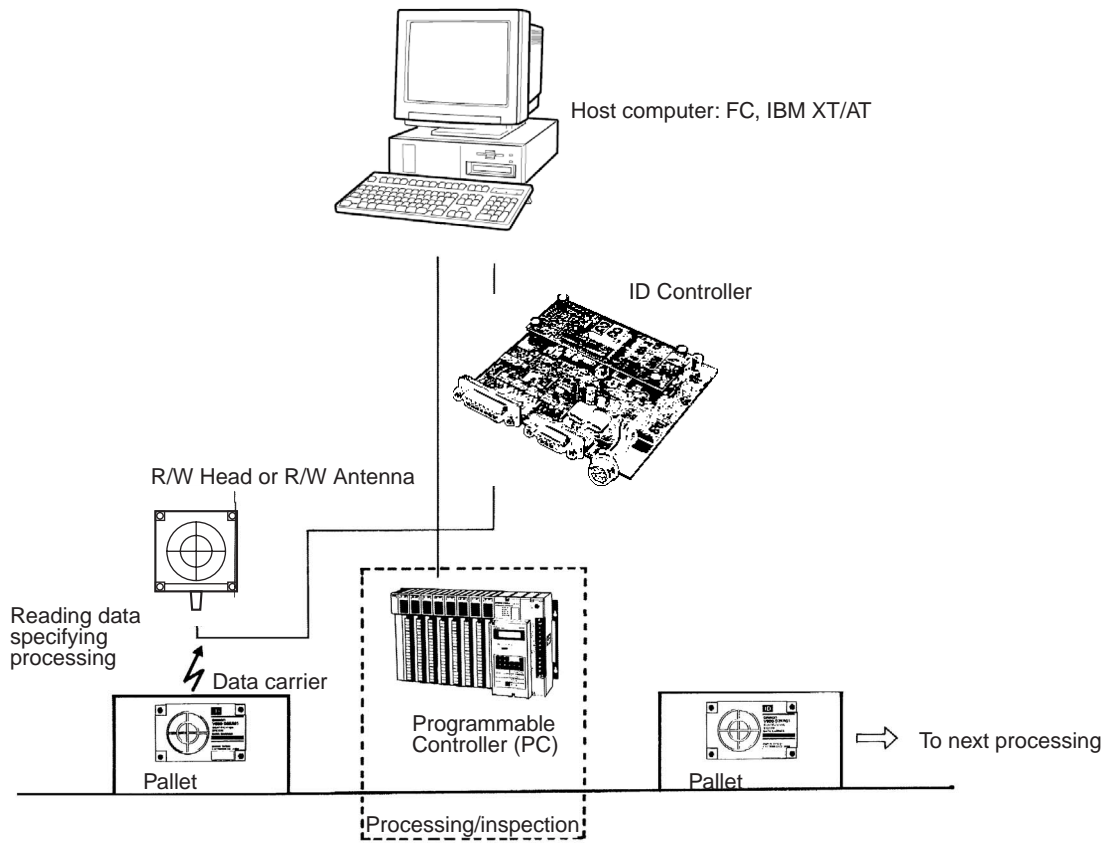

When a command is sent from the host computer (FC, IBM XT/AT compatible) to the ID Controller, the R/W Head (or R/W Antenna) enters the stand-by state, waiting for a signal from the DC.

When a DC enters the area where it can communicate with the R/W Head, the data (model number and data for processing or inspection) of a memory area specified by the command can be written or read to or from the DC or a response transmitted to the host computer. For example, when the memory contents of the DC have been read, the host computer transmits a command on how to process or test a workpiece to a Programmable Controller (PC).

When the processing or testing has been completed, the PC transmits process or test data to the host computer.

## 1-4 User I/O

The ID Controller is equipped with two user outputs that can be turned ON/OFF by a command from the host controller, and also two user inputs whose ON/OFF status can be read. These I/Os can be manipulated independently of each other, so that ON/OFF signals can be processed easily and at low cost by a host computer. The following figure shows an example in which the ID Controller is used for batch reading of test data.

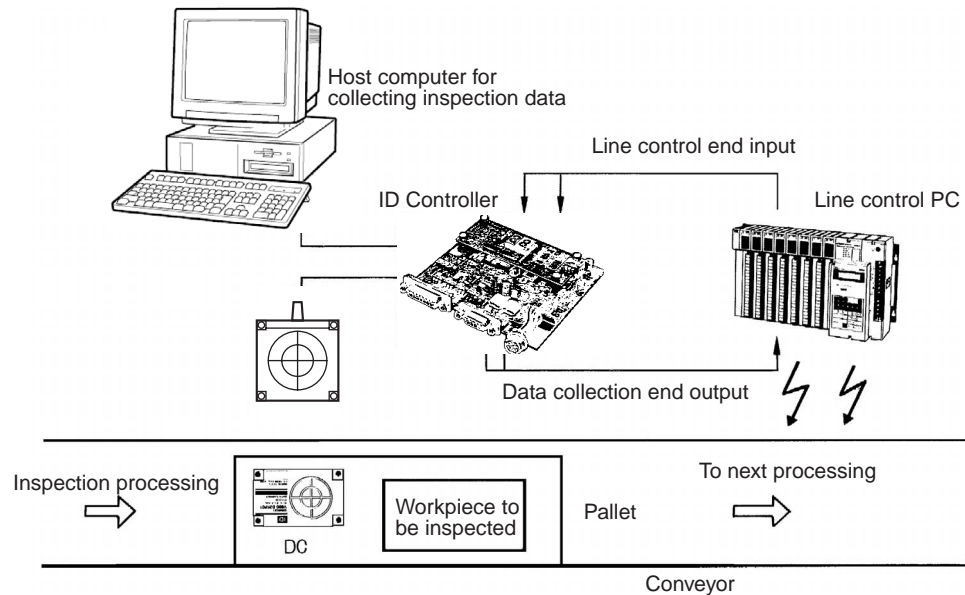

### Outline of Operation

- 1,2,3...**
1. When there is a workpiece to be tested, the PC controlling the line instructs the conveyor to stop the workpiece at a predetermined place.
  2. When the workpiece has been stopped, the PC issues a signal indicating that the line control action has been completed.
  3. A host computer reads the signal to the ID Controller through a user input, and reads the test data.
  4. When the test data has been read, the host computer issues a data collection completion signal through the user output of the ID Controller.
  5. In response to the data collection completion signal, the PC sends the workpiece to the next process.

# SECTION 2

## Nomenclature and Specifications

This section provides the names and functions of the ID Controller parts and also provides the ID Controller's specifications.

2-1	Names and Functions of Parts . . . . .	8
2-2	Specifications and Characteristics . . . . .	10
2-3	I/O Specifications . . . . .	10
2-3-1	External I/O Specifications . . . . .	10
2-4	Communications Specifications . . . . .	12
2-5	Outline Size . . . . .	13

## 2-1 Names and Functions of Parts

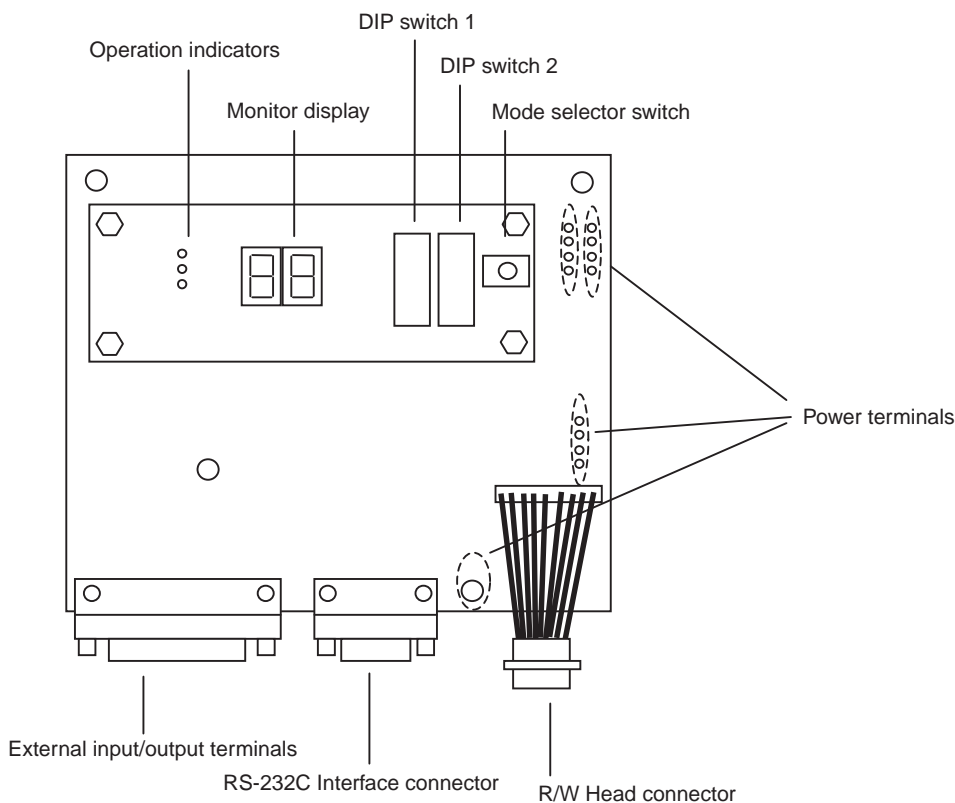

### Operation Indicators

Name	Color	Function
POWER	Green	Lit when power is supplied.
HEAD	Yellow	Lit when R/W Head is executing communications processing.
STOP	Red	Lit when an error (such as CPU error or memory error) has occurred or when external reset signal has been input.

### Monitor Display

- 1,2,3... 1. Error Display Mode: Displays end code of command processing. The end code is displayed as a 2-digit hexadecimal number.

Hexadecimal	0	1	2	3	4	5	6	7	8	9	A	B	C	D	E	F
Indication	0	1	2	3	4	5	6	7	8	9	A	b	C	d	E	F

2. I/O Display Mode: Displays the ON/OFF status of the I/O terminal and indicates the occurrence of an error.

Indication of input status  
(From the left: RESET, TRIG, IN1, and IN2)

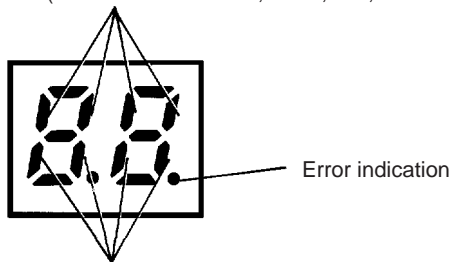

Indication of output status  
(From the left: RUN, CMPL, OUT1, and OUT2)

**Note** The Display Mode is set by the internal DIP switch.

**Power Supply**

V600-CM1D needs both 24 VDC and 5 VDC power supply. And please connect one of the below power terminals as (1), (2) and (3).

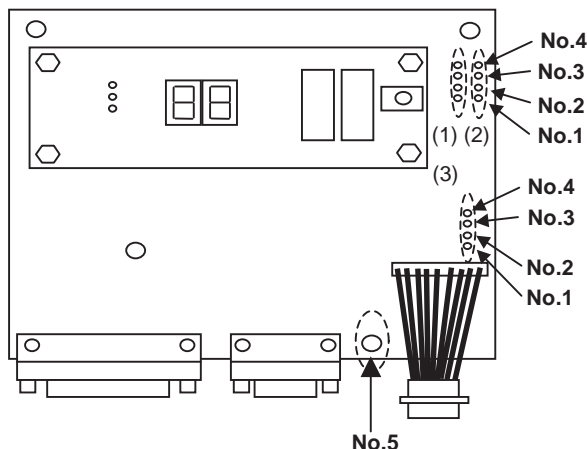

Through holes as (1), (2) and (3) are connected one another on the circuit substrate.

Pin No.	Function
1	24 VDC supply
2	GND for 24 VDC
3	5 VDC supply
4	GND for 5 VDC
5	Protective conductor terminal. Connect a ground line grounded at less than 100 Ω.

**External Input Terminals**

Name	Function
RESET	External reset input for emergency stop.
TRIG	Trigger input informing the Controller of the processing start time of the DC. The conditions under which this input signal is to be issued can be set by the DIP switch.
IN1	User input 1 that can be manipulated by a command.
IN2	User input 2 that can be manipulated by a command.
COM	COM Common input terminal.

**External Output Terminals**

Name	Function
RUN	Turns ON when the ID Controller operates normally and can communicate with the host controller. This signal is turned OFF in the test mode.
CMPL	Turns ON when communications with the DC have been completed, and turns OFF when transmission of a response has started.
OUT1	User output 1 that can be manipulated by a command.
OUT2	User output 2 that can be manipulated by a command.

**R/W Head Connector**

Connects the R/W Head (R/W Antenna).

**RS-232C Interface Connector**

Connector for communications with the host computer. Conforming to RS-232C, this connector can be connected to a general-purpose factory computer or personal computer.

## 2-2 Specifications and Characteristics

### Specifications

Item	Specifications
Supply voltage	24 VDC, 5 VDC
Operating voltage range	24 VDC: 20.4 to 26.4 VDC 5 VDC: 4.5 to 5.5 VDC
Power Consumption	24 VDC: 300 mA max. 5 VDC: 300 mA max.
Operating temperature	0 to 50°C (without condensation or icing)
Operating humidity	35% to 85 % (without condensation)
Storage temperature	-15 to 70°C (without condensation or icing)
Storage humidity	35% to 95 %

### Characteristics

Item	Specifications
Self-diagnosis function	CPU error, memory error, power failure, communications error check

## 2-3 I/O Specifications

### 2-3-1 External I/O Specifications

#### Input Specifications (RESET, TRIG, IN1, IN2)

Item	Specifications
Input voltage	20.4 to 26.4 VDC (including ripple)
Input impedance	2.2 kΩ
ON voltage	19 V min.
OFF voltage	5 V max.
Input response time	70 ms max.

#### Output Specifications (RUN, CMPL, OUT1, OUT2)

Item	Specifications
Max. switching capacity	20.4 to 26.4 VDC (including ripple), 100mA
Leakage current	100 μA max.
Residual voltage	2.0 V max.

- Note**
- (1) When the RESET input is ON, the CPU stops and the STOP indicator light.
  - (2) If the terminals are short-circuited without load, the internal transistor may be damaged.

Wiring Examples of I/O Devices

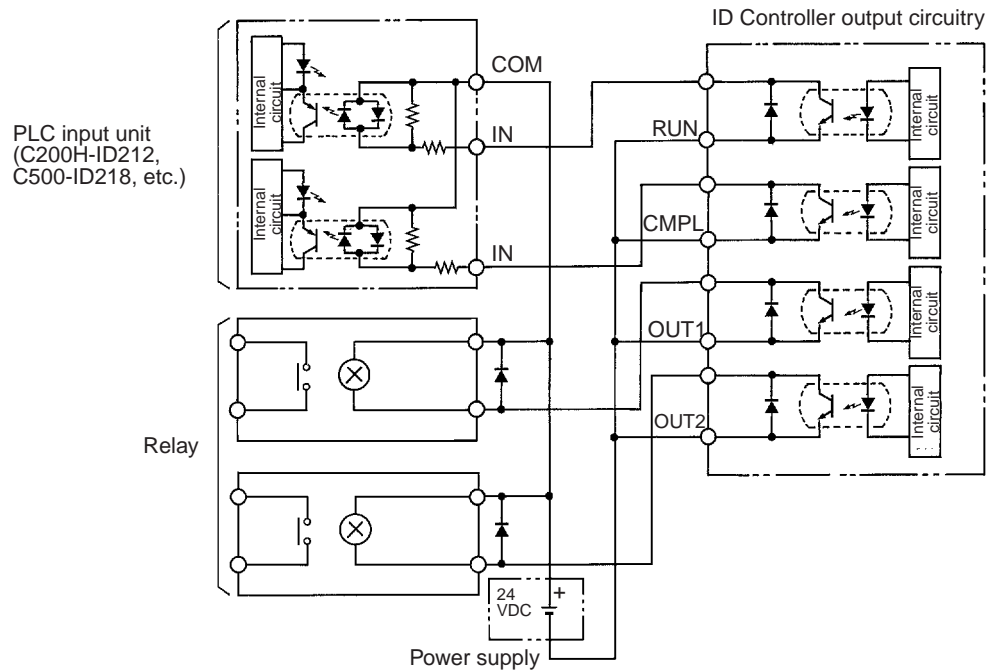
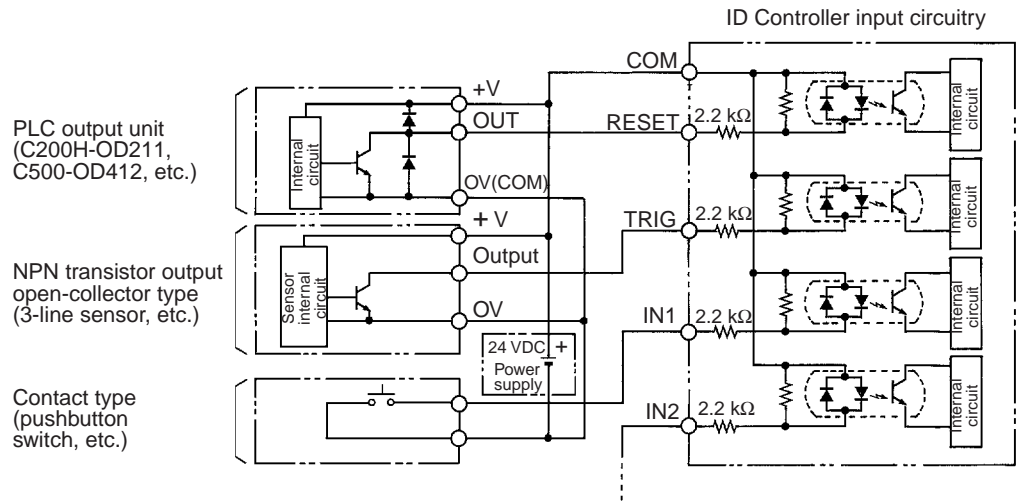

**Note** Use the bi-directional Input Unit on the PC.



## 2-4 Communications Specifications

The communications specifications conform to RS-232C, and a general-purpose factory computer or personal computer can be connected to the ID Controller. The communications protocol conform to SYSWAY (SYSMAC host computer system).

### Host Computer Communications Specifications

Standard	RS-232C
Transmission path connection	Point-to-point
Communications method	Two-line, half-duplex
Synchronization method	Start-stop synchronization (stop bit = 1 or 2)*
Transmission rate	2,400/4,800/9,600/19,200 bps*
Transmitted codes	ASCII (7 bits) or JIS*
Communications control procedure	Point-to-point procedure
Error detection	Vertical parity (even/odd/none)*
Line length	15 m max.
Connector	XM2A-0901 (plug): 1 set is supplied with ID Controller XM2S-0911 (hood): As an accessory
Recommended cable	5PX28AWG, 7 dia.

**Note** \*Set by the internal DIP switch.

### Checking the Version

The ID Controller version can be checked using the following method.

- 1,2,3...**
1. Turn ON the power supply to the V600-CM1D.
  2. The version will be displayed on the monitor as shown below.



## 2-5 Outline Size

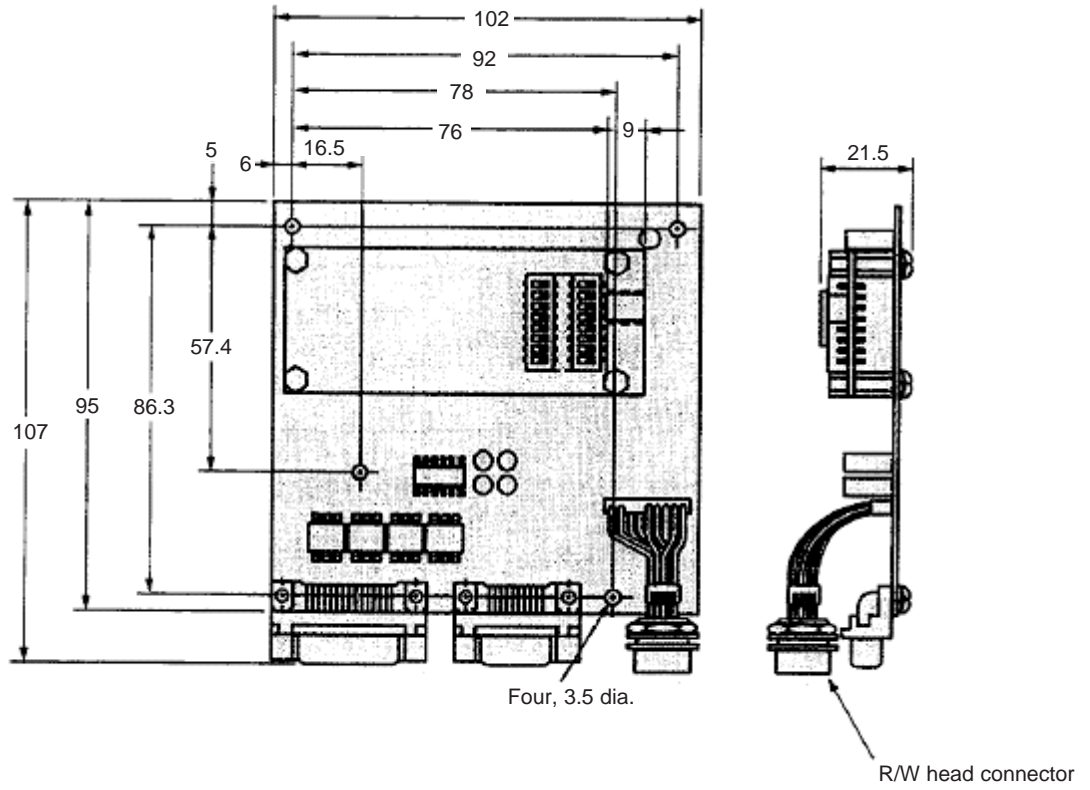

# SECTION 3

## Switch Setting and Wiring

This section provides the DIP switch settings and the wiring instructions required before operating the ID Controller.

3-1	DIP Switch Setting . . . . .	16
3-2	Installation Environment . . . . .	19
3-3	Wiring . . . . .	19
3-4	RS-232C Interface Connection . . . . .	20

### 3-1 DIP Switch Setting

The communications interface is set by the DIP switches on the ID Controller. To gain access to the DIP switches, remove the cover on the monitor unit connector. Set the DIP switches in accordance with the communication specifications of the host computer.

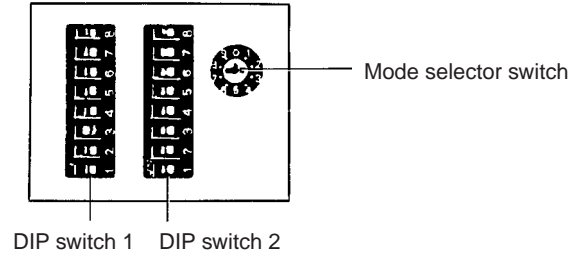

#### Setting

##### Mode Selector Switch

The ID Controller operates as follows depending on the mode selector switch setting.

Settings	Mode	Operation
0	RUN	Operates as specified by command from host controller. Although the IC Controller operates in the same manner regardless of where the selector switch is set (positions 0 through 3), set the switch to position 0.
1		
2		
3		
4	TEST	Continuously reads 1 byte from address 0000 (read test).
5		Continuously writes 1 byte from address 0000 (write test).
6		RESERVED
7		Used by manufacturer for repairs.
8 and 9	Inhibited	

**Note** Do not set switches 7 through 9 during normal operation. The Mode is set to “0” when the unit is delivered.

#### Modes

##### RUN Mode

The ID Controller operates in two Modes: RUN and TEST Modes.

In this Mode, the ID Controller operates as specified upon a command sent from the host controller, and sends the result of the operation to the host controller as a response.

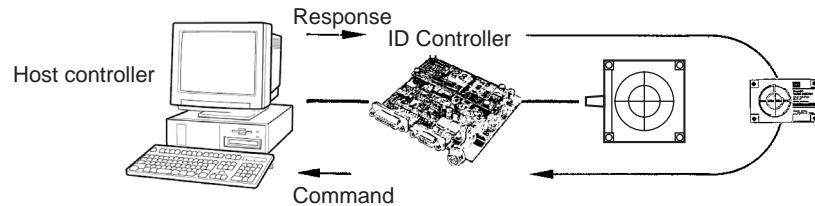

**TEST Mode**

Communications testing can be conducted between the ID Controller and a DC in the off-line state. The ID Controller repeatedly communicates with a DC at 1-second intervals. During communication with the DC, the HEAD Indicator lights. When the processing has been completed, an end code, which is the result of the processing, is displayed on the monitor.

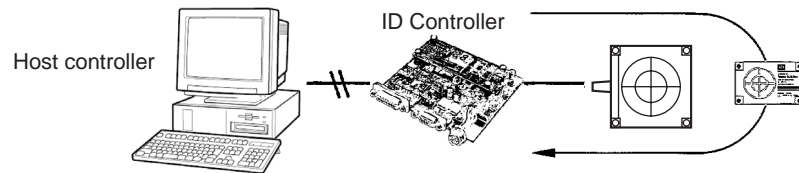

In the TEST Mode, two kinds of tests can be conducted: Read and Write Tests. The Read Test repeatedly reads 1-byte data, while the Write Test repeatedly writes 1-byte data. At this time, however, the contents of the DC's data have not changed. Use this TEST Mode for initial checking of the system.

**Write Command Memory**

A write command executed by this Controller is recorded until either the next write command or the Power reset is executed. The write commands of the Controller include write, auto write, and polling write commands. The recorded write command can be executed by a repeat command.

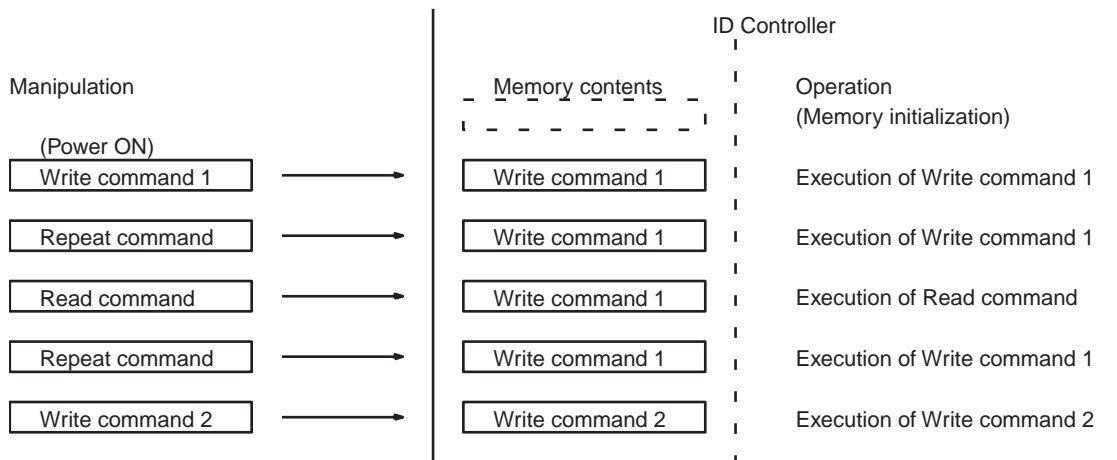

**Trigger Input**

The ID Controller is provided with a trigger input that informs the Controller when to start processing the DC. After receiving a command from the host controller, the ID Controller waits until the conditions of this trigger input are satisfied, and then starts communications with the DC.

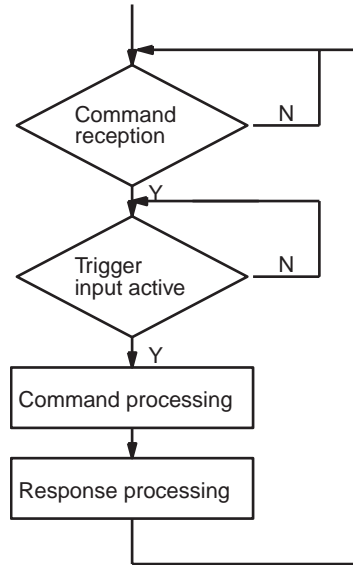

**Note** Even if there are changes to the trigger input status while the ID Controller is processing a command, processing is not suspended.

The condition of the trigger input can be specified to be L level (OFF) or H level (ON) by using a DIP switch.

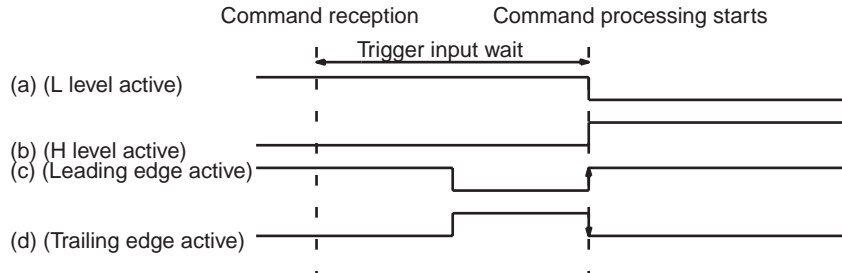

When the auto command is used, the ID Controller waits for the DC approach after the trigger input has become active. Consequently, the Controller does not perform Read/Write processing even if a DC approaches before the trigger input becomes active.

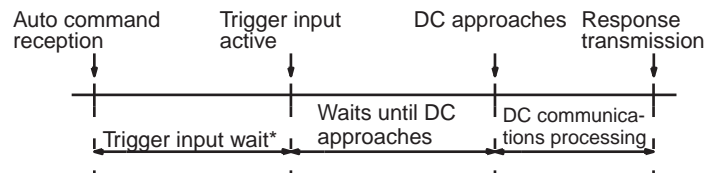

\*The ID Controller does not perform processing even when a DC approaches in the trigger input wait state.

**Note** When the trigger input is not used, set the trigger condition to L level, and open the TRG terminal (set pins 1 and 2 of DIP switch 2 to the OFF positions).

## 3-2 Installation Environment

Although the ID Controller V600-CM1D has a high reliability and strong environmental durability as a control component, take the following into consideration when installing the ID Controller in order to improve the reliability of the overall system and to make the best use of its functions:

### Installation Location

Do not install the ID Controller at the following locations:

- Where the temperature falls below  $-10^{\circ}\text{C}$  or rises above  $+55^{\circ}\text{C}$ , or where the temperature fluctuation is great and condensation is generated.
- Where the relative humidity falls below 35% or exceeds 85%.
- Where it is subject to corrosive gas, flammable gas, dust, salt, and iron chips.
- Where it is subject to direct vibration or shock.
- Where it is subject to direct sunlight.
- Where it is subject to splashes of water, oil, and chemical substances.

## 3-3 Wiring

### Input and Output lines

PIN No.	Name	I/O
1	COM	Input
2	RESET	Input
3	TRIG	Input
4	IN1	Input
5	IN2	Input
6	TBD	---
7	TBD	---
8	RUN	Output
9	COM1	Output
10	CMPL	Output
11	COM2	Output
12	OUT1	Output
13	COM3	Output
14	OUT2	Output
15	COM4	Output

The recommended connector: Plug type XM2A-1501 (OMRON)  
Hood type XM2S-1511 (OMRON)

**RESET Signal Input**

Make sure that the input voltage of the RESET signal does not exceed the maximum voltage (26.4 V). If this is exceeded, the ID Controller may malfunction.

To improve the noise immunity, separate the wiring of the input lines from high-tension equipment or power lines.

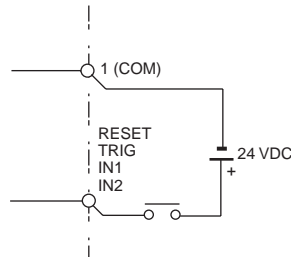

**ERROR Signal Output**

The maximum switching capacity of the output terminals is 24 VDC (+10%/−15%), 100 mA. If a voltage or load that exceeds the maximum switching capacity is used, the ID Controller may malfunction. Use of an auxiliary relay (24 VDC, 100 mA max.) in the output circuit is recommended.

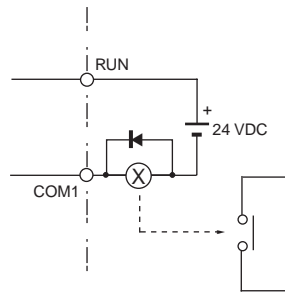

**3-4 RS-232C Interface Connection**

Signal name	Abbr.	I/O	Pin no.
Ground	GR	—	1
Signal ground	SG	—	9
Send data	SD	Output	2
Receive data	RD	Input	3
Request to send	RS	Output	4
Clear to send	CS	Input	5

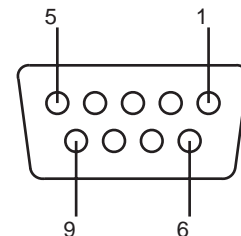
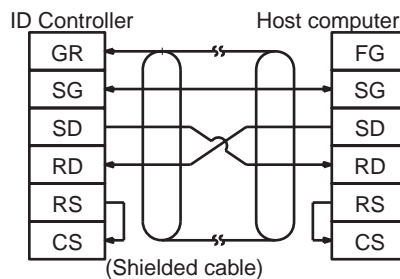

- Note**
1. Ground the shielded cable at either the ID Controller side or host computer side to prevent malfunctioning. The above left figure shows an example of shielded cable grounding at the ID Controller side.
  2. Internally short-circuit pins 4 (RS) and 5 (CS).



# SECTION 4

## Communications

This section provides information on the communications aspects of the RFID System.

4-1	Movement of Data Carrier and Command Status . . . . .	22
4-2	Memory Map of Data Carrier . . . . .	26
4-2-1	Memory Map . . . . .	26
4-2-2	Format of Production Date (Written by Manufacturer) . . . . .	26
4-2-3	Write Protect Function . . . . .	27
4-3	Command Format . . . . .	30
4-4	Types of Commands and Responses . . . . .	34
4-4-1	Read (RD) . . . . .	34
4-4-2	Write (WT) . . . . .	35
4-4-3	Expansion Read Command (XR) . . . . .	35
4-4-4	Expansion Write Command (XW) . . . . .	36
4-4-5	Auto Read (AR) . . . . .	37
4-4-6	Auto Write (AW) . . . . .	38
4-4-7	Polling Auto Read (PR) . . . . .	38
4-4-8	Polling Auto Write (PW) . . . . .	39
4-4-9	Command Processing Terminating Command (AA) . . . . .	40
4-4-10	Data Check Command (MD C/K) . . . . .	40
4-4-11	Data Management Command (MDS/MDL) . . . . .	41
4-4-12	Write Processing Repeat Command (RP) . . . . .	42
4-4-13	Controller Control Command (CC) . . . . .	43
4-4-14	Error Information Read Command (CF) . . . . .	43
4-4-15	Test Command (TS) . . . . .	44
4-4-16	Abort Command (XZ) . . . . .	44
4-4-17	Command Undefined Response (IC) . . . . .	45
4-4-18	Error Response . . . . .	45
4-4-19	End Code List . . . . .	45
4-5	Example of Communications Program . . . . .	46
4-6	Communication Time . . . . .	47
4-6-1	Communication Time . . . . .	47
4-6-2	TAT (Turn Around Time) . . . . .	48

## 4-1 Movement of Data Carrier and Command Status

### Communications Control Procedure

The host communication control procedure conforms to the OMRON SYSWAY procedure.

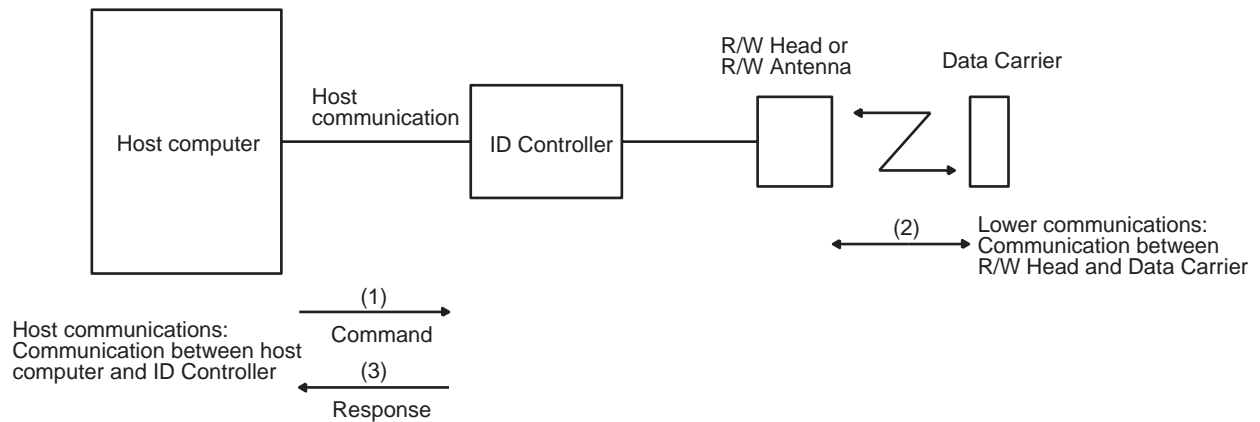

### Description

- 1,2,3...**
1. The host computer transmits commands to the ID Controller.
  2. The ID Controller analyzes the commands from the host computer, executes lower communications, and writes/reads data to/from a DC.
  3. When a read command has been executed, the ID Controller transmits the contents of the data it has read and a responds to the host computer. When a write command has been executed, the Controller transmits a response indicating the end of processing to the host computer.

### Command Reception

The ID Controller assumes the following status in response to a command sent from the host computer:

#### Command Wait Status

In this status, the ID Controller processes no command and is ready to receive any command.

#### Command Processing Status

In this status, the ID Controller receives and processes a read/write (including expansion command) or auto read/write command, and returns a response to the host computer after the processing has ended. While the ID Controller is in this status, the Controller only receives a command that will terminate the current command, and an abort command.

#### Polling Auto Subcommand Wait Status

When the ID Controller has received a polling auto command,

- a) the Controller returns the result of the processing as a response to the host computer after the processing with the DC has been completed and a polling processing inquiry command has been sent from the host computer.
- b) the processing of the ID Controller can be terminated by a polling processing termination command from the host computer.

When the ID Controller is in the polling auto subcommand wait status, it can receive only a polling subcommand (inquiry, termination) and an abort command.

**Read/Write Function**

Read/Write Command Processing: The read/write function is used for communication when the Data Carrier is motionless. Therefore, it must be confirmed that the Data Carrier is at a specified position, i.e., in the communication area of the R/W Head. If the Data Carrier is missing, the ID Controller returns a response to that effect.

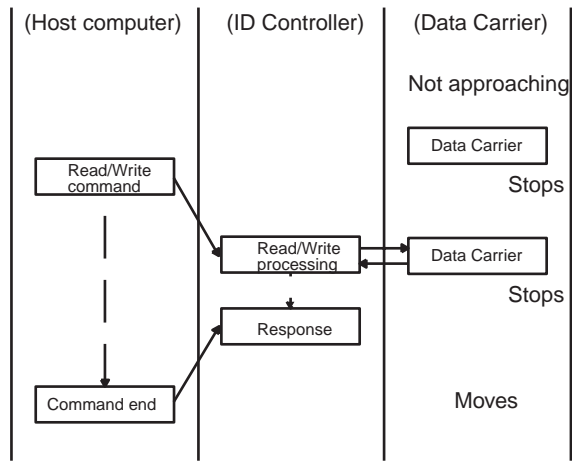

**1,2,3...**

1. The host computer confirms that the Data Carrier is at a specified position and transmits a command to the ID Controller.
2. The ID Controller performs write or read processing in accordance with the command.
3. After the processing is complete, the ID Controller returns a response to the host computer to indicate that the processing has ended. The host computer, on receiving the response, moves the workpiece (with a Data Carrier) on the conveyor line.

**Auto Read/Write Function**

Auto Command Processing: When the ID Controller has received an auto command, it does not respond to the host computer until the Data Carrier approaches. When the Data Carrier approaches, the communication line between the Controller and the host computer becomes busy.

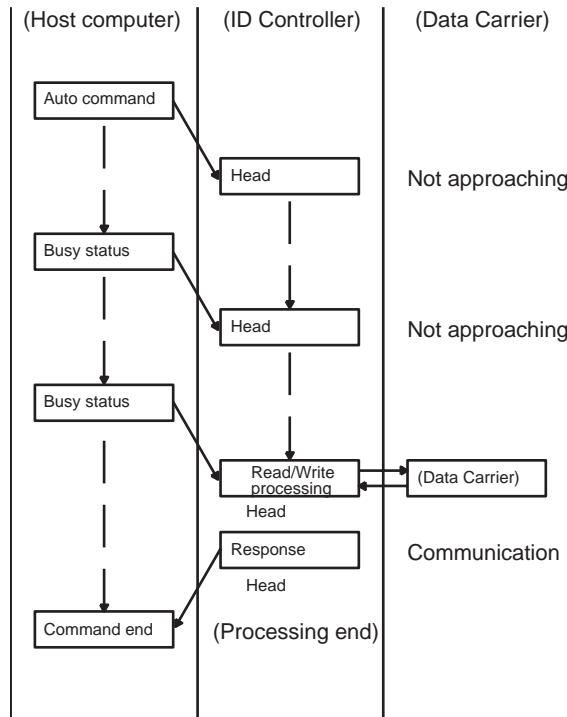

- 1,2,3...**
1. The host computer transmits an auto command to the R/W Head.
  2. The ID Controller does not respond to the host computer until the Data Carrier approaches, and only at this time does the host computer become busy.
  3. When the Data Carrier passes by the R/W Head, data is read or written.
  4. After the processing has been completed, the ID Controller returns a response to the host computer to indicating the end of processing.

For further details, refer to Appendix B.

**Polling Function**

When an ordinary auto command is executed, the ID Controller does not respond to the host computer until the Data Carrier approaches. Only when the Data Carrier approaches, the communication line between the host computer and the ID Controller becomes busy. However, when a polling auto command is executed, the ID Controller returns a response to the host computer on request. Therefore, the communication line ceases to be busy.

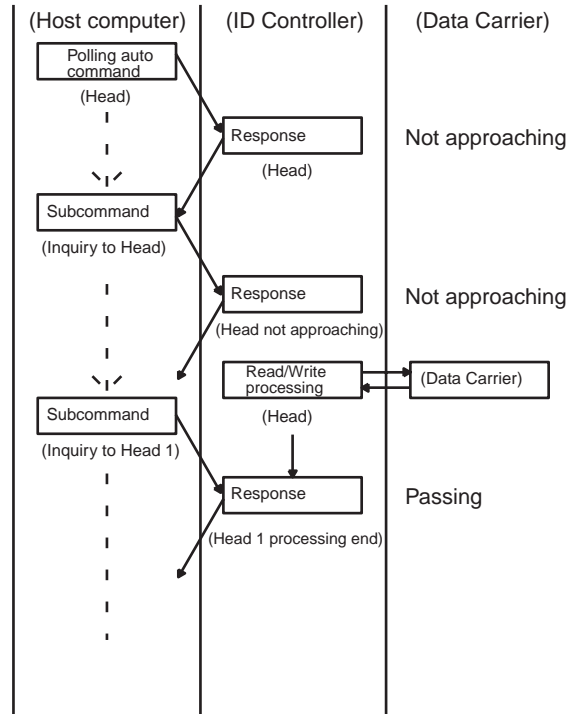

**1,2,3...**

1. The host computer sends a polling auto command to Head 1.
2. As soon as the ID Controller has received the command, it responds to the host computer to indicate the reception of the command.
3. The host computer can make an inquiry on the progress of the processing or terminate the polling auto processing by using a subcommand.
4. If the Data Carrier does not approach, the ID Controller responds to that effect to the host computer in response to a subcommand making an inquiry.
5. When the Data Carrier passes by the R/W Head, read or write processing is performed.
6. When processing has ended, the ID Controller responds to the host computer to indicate the end of the processing in response to a subcommand making an inquiry.

## 4-2 Memory Map of Data Carrier

### 4-2-1 Memory Map

The Data Carrier (DC) has a memory area of up to 8 KB. Data of 1 byte can be written to an address of the memory area.

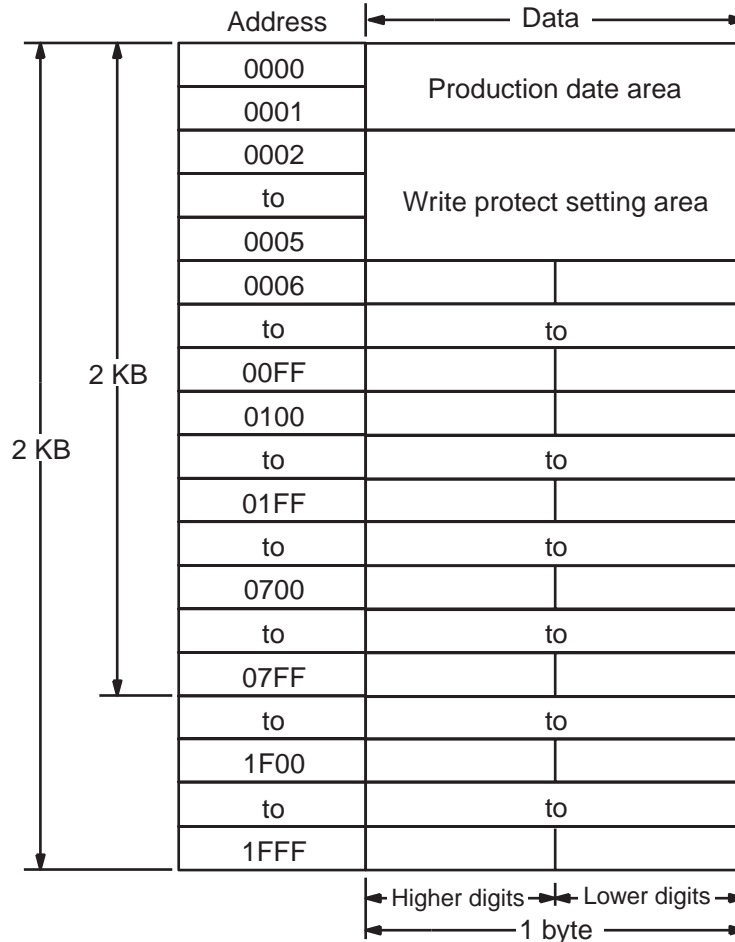

**Note** Addresses 0000 and 0001 form a production date area in which data is factory-set for shipment. Addresses 0002 through 0005 are used to set write protection.

### 4-2-2 Format of Production Date (Written by Manufacturer)

To manage the battery life of the Data Carrier, the date of production is written to the first 2-byte area of the Data Carrier memory as a factory-set condition for shipment. The data in this area can be read, but no data can be written to this area by the user. If a write operation is performed on this area by mistake, an error will occur.

**Contents of Production Date Area**

Address	Bit							
	7	6	5	4	3	2	1	0
0000	Digit 10 of month				Digit 1 of month			
0001	Digit 10 of year				Digit 1 of year			

- Note**
1. Lower 2 digits of year are recorded (1991 → "91").
  2. Month is expressed in two digits (June → "06," October → "10").
- Example: June, 1991

Address	Bit							
	7	6	5	4	3	2	1	0
0000	0	0	0	0	0	1	1	0
	0				6			
0001	1	0	0	1	0	0	0	1
	9				1			

- Note** The battery life of the Data Carrier can be managed not only by reading the sticker on the battery, but also by the host computer through software by using a read command.

**4-2-3 Write Protect Function**

The write protect function protects important data stored in the memory of the Data Carrier, such as product number and model, from inadvertent write access. With this function, the data in a specified memory area can be protected. It is recommended that important data be write-protected as follows:

**Setting Write Protect Function**

The write protect function is set by 4 bytes of the addresses 0002 through 0005 of the Data Carrier's memory. Whether or not the write protect function is effected is specified by the most significant bit of address 0002.

Address	Bit							
	7	6	5	4	3	2	1	0
0002	YES/ NO	Higher 2 digits of start address						
0003	Lower 2 digits of start address							
0004	Higher 2 digits of end address							
0005	Lower 2 digits of end address							

Write protect execution bit (most significant bit of address 0002)

1: Write-protected

0: Not write-protected

Setting area:

Address	2 KB type	8 KB type
Start address	0006 to 07FF	0006 to 1FFF
End address	0006 to 07FF	0006 to 1FFF

- Note** Use addresses 0002 through 0005 as a write protect area.

To protect addresses 0006 through 07FF:

Address	Higher digits				Lower digits			
	7	6	5	4	3	2	1	0
0002	1	0	0	0	0	0	0	0
	8				0			
0003	0	0	0	0	0	1	1	0
	0				6			
0004	0	0	0	0	0	1	1	1
	0				7			
0005	1	1	1	1	1	1	1	1
	F				F			

To not protect addresses:

Address	Higher digits				Lower digits			
	7	6	5	4	3	2	1	0
0002	0	0	0	0	0	0	0	0
	0				0			
0003	0	0	0	0	0	0	0	0
	0				0			
0004	0	0	0	0	0	0	0	0
	0				0			
0005	0	0	0	0	0	0	0	0
	0				0			

### Example of Setting Write Protect Function

- 1,2,3... 1. To write-protect addresses 0015 through 0120. (End address)

Address	Bit							
	7	6	5	4	3	2	1	0
0002	1	0	0	0	0	0	0	0
	8				0			
0003	0	0	0	1	0	1	0	1
	1				5			
0004	0	0	0	0	0	0	0	1
	0				1			
0005	0	0	1	0	0	0	0	0
	2				0			

- To write-protect only 1 byte <start address = end address> Set the same address as the start and end addresses.
- If the end address exceeds the last address of the Data Carrier memory (end address > 07FF):  
Since the memory area of the Data Carrier is from 0000 through 07FF, addresses up to 07FF are write-protected.
- If start address exceeds end address (start address > end address):  
Addresses from 0006 through end address, and start address through 07FF are write-protected.



<Example with 2KB Data Carrier>

With an 8KB Data Carrier, the last address is 1FFF.

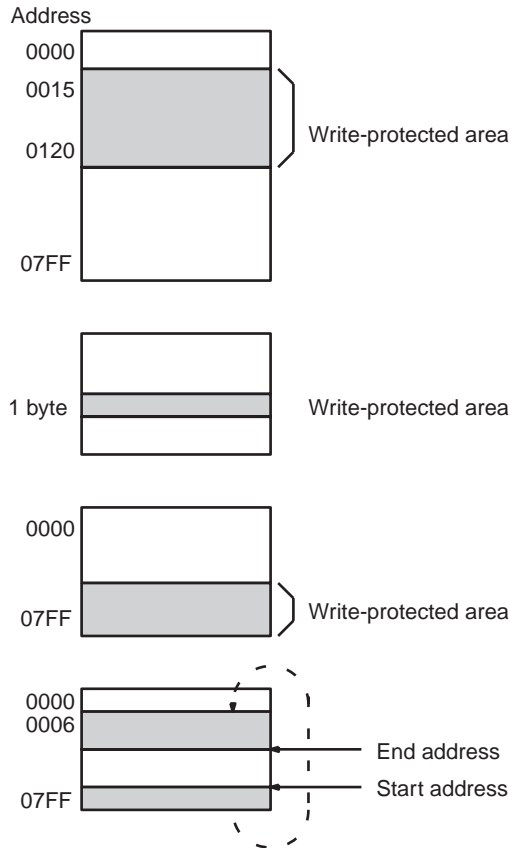

**Note** The above example is when the memory capacity of the Data Carrier is 2 KB. When the Data Carrier with an 8 KB memory is used, the last address is 1FFF.

**Canceling Write Protection**

To cancel write protection, clear the most significant bit of address 0002 to 0. The write protection is canceled and both the start and end addresses specified in addresses 0002 through 0005 become invalid.

**WARNING**

The SRAM-type Data Carrier has a built-in lithium battery which can combust or explode if mishandled. Do not disassemble the Data Carrier, or subject it to high pressure or high temperatures (of 100°C or more), or dispose of it by incineration.



### 4-3 Command Format

#### Command/Response List

No.	Command	Header	Description	
1	Read	RD	Reads or writes data to or from the Data Carrier. If the Data Carrier is missing, an error response returns.	
2	Write	WT		
3	Expansion read	XR		
4	Expansion write	XW		
5	Auto read	AR	Reads or writes data to or from the Data Carrier. If the Data Carrier is missing, waits until the Data Carrier approaches	Responds upon completion of command processing.
6	Auto write	AW		Can inquire about the result of command processing
7	Polling auto read	PR		
8	Polling auto write	PW		
9	Command processing terminate	AA	Terminates the processing of commands other than polling command.	
10	Data management command	MD	Checks the data of the Data Carrier's memory. Manages the number of overwriting operations on the EEPROM-type Data Carrier.	
11	Write processing repeat	RP	Repeatedly executes the write command that was previously executed.	
12	Controller control	CC	Performs user input/output operation.	
13	Error information read	CF	Reads a log information error.	
14	Test	TS	Returns as a response a test message sent from the host computer.	
15	Abort (reset)	XZ	Restores the ID Controller to previous state upon power application. No response is returned.	
16	Command undefined response	IC	The response returned by the ID Controller when the ID Controller receives an undefined command from the host computer.	

#### Command/Response Format

The command sent from the host computer to the ID Controller, and the response returned from the ID Controller to the host computer are in the following format:

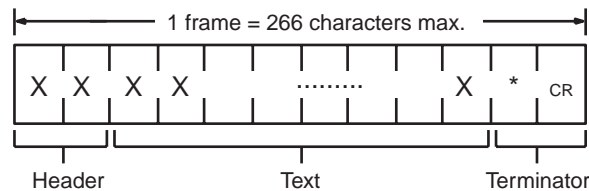

Type	Description	
Header	Command	Two-character symbol indicating operation.
	Response	Symbol same as header of executed command

Type	Description	
Text	Command	Contents of processing: – ASCII/HEX code specification – R/W Head no. specification (fixed to 1) – Processing start address – Number of bytes to be processed (for read command), write data (for write command)
	Response	Result of processing – End code – Read data (for read command)
Terminator	Indicates end of command or response. Note: * indicates "2A"H of ASCII code, and CR indicates "0D"H.	

If the length of an expansion command exceeds 266 characters, or the length of a response to an expansion command exceeds 256 characters, the command or response is divided into several frames as follows. At this time, the terminator (\*CR) is appended to the last frame, and a delimiter (CR) is appended to the other frames.

If response length exceeds 256 characters (for expansion read command):

After transmitting a response which is not the last frame, the ID Controller transmits the next response frame when it has received a delimiter (CR) from the host controller.

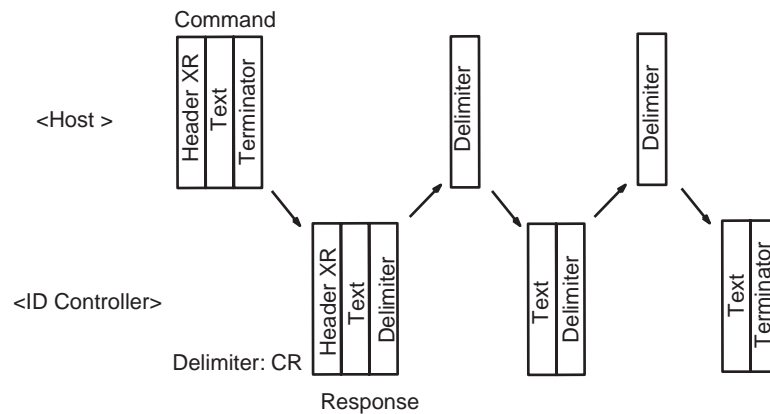

If command length exceeds 266 characters (for expansion write command):

When the ID Controller receives a command which is not the last frame, it transmits a delimiter (CR) to the host controller, and is ready to receive the next command frame.

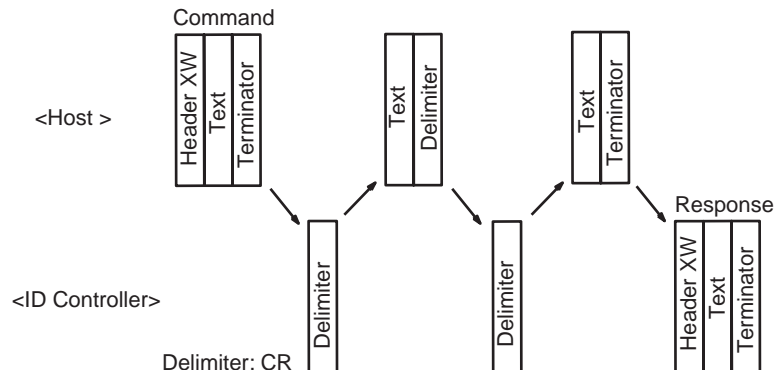

**Specifying Data Code**

Whether the read or write data is treated as an ASCII (or JIS 8) code or HEX code is specified in a command.

**ASCII (JIS 8 Code)**

When the data length is specified to be 7 bits by the DIP switch of the ID Controller, ASCII is specified. When the data length is specified to be 8 bits, the JIS 8 code is specified.

One character of ASCII or JIS 8 code data occupies 1 byte (1 address) of the Data Carrier memory.

Example of specifying ASCII code:

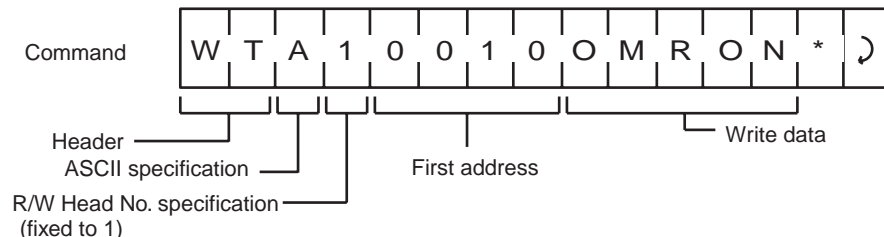

Data Carrier memory address:

Address			
0010	4	F	"O"
0011	4	D	"M"
0012	5	2	"R"
0013	4	F	"O"
0014	4	E	"N"

**Note** For ASCII (JIS 8 code), refer to Appendix A.

**Hex Code**

One character is treated as a hexadecimal number. Therefore, only numerals 0 through 9 and A to F can be accepted.

Two characters of data occupy 1 byte (1 address) of the Data Carrier memory. Therefore, specify data in 2-character units (in even numbers) when using a write command. If an odd number of data is specified by mistake, an error occurs.

Example of specifying HEX code:

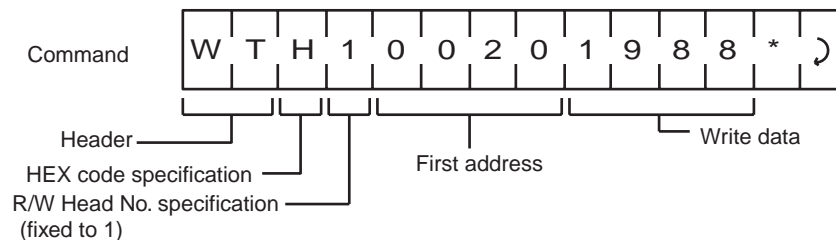

Data Carrier memory address:

Address		
0020	1	9
0021	8	8

← 1 byte →

**Range of Address and Number of Bytes**

**Read Command**

Other than expansion read command:

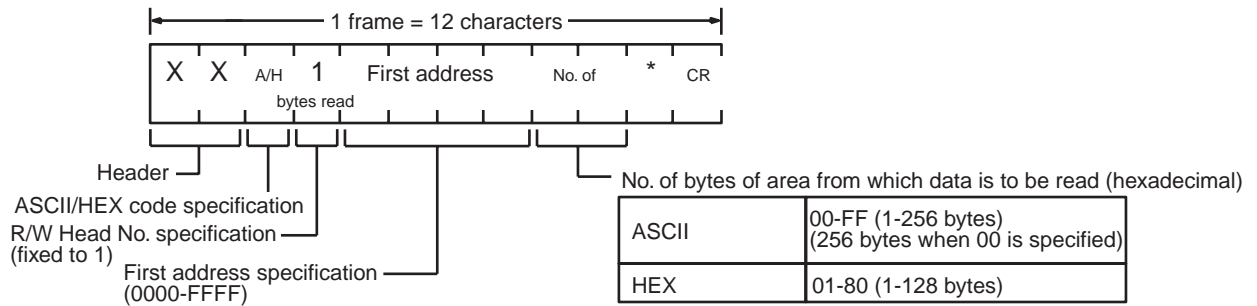

Expansion read command:

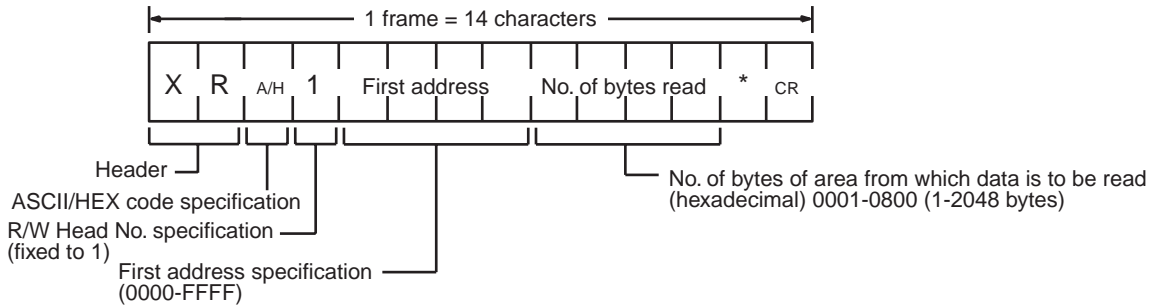

**Write Command**

Other than expansion write command:

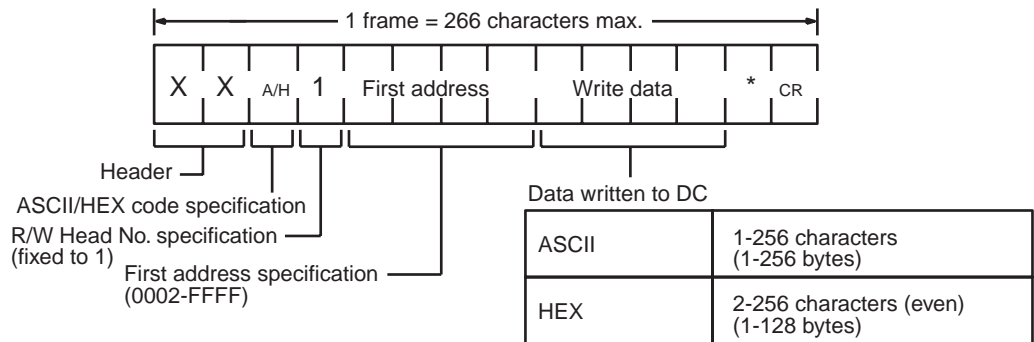

Expansion write command:

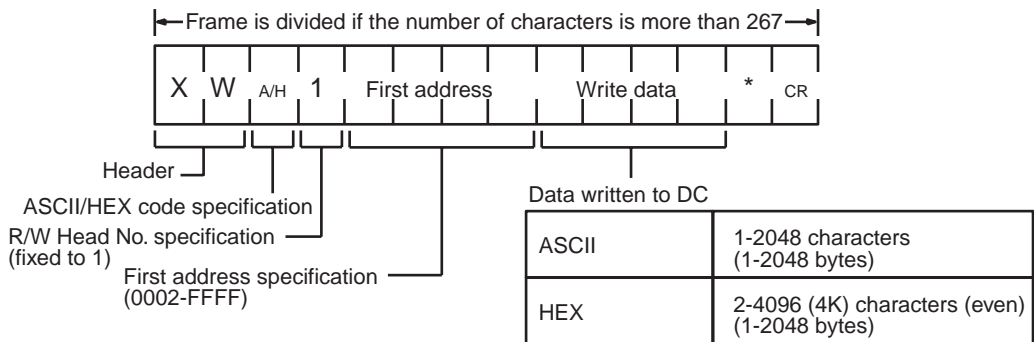

**Note** To divide a frame into several frames, make sure that one frame is of 266 characters or less.

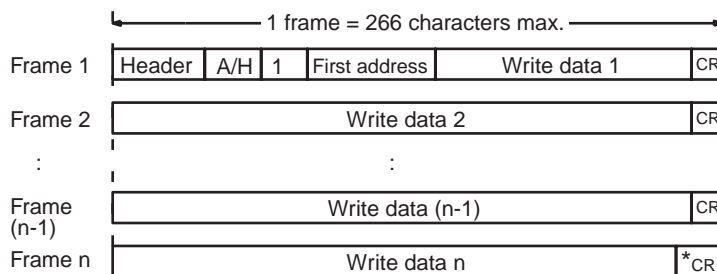

## 4-4 Types of Commands and Responses

### 4-4-1 Read (RD)

Reads data from the Data Carrier. If the Data Carrier is missing, an error response (end code: 72 = Data Carrier missing) is returned.

#### Command Format

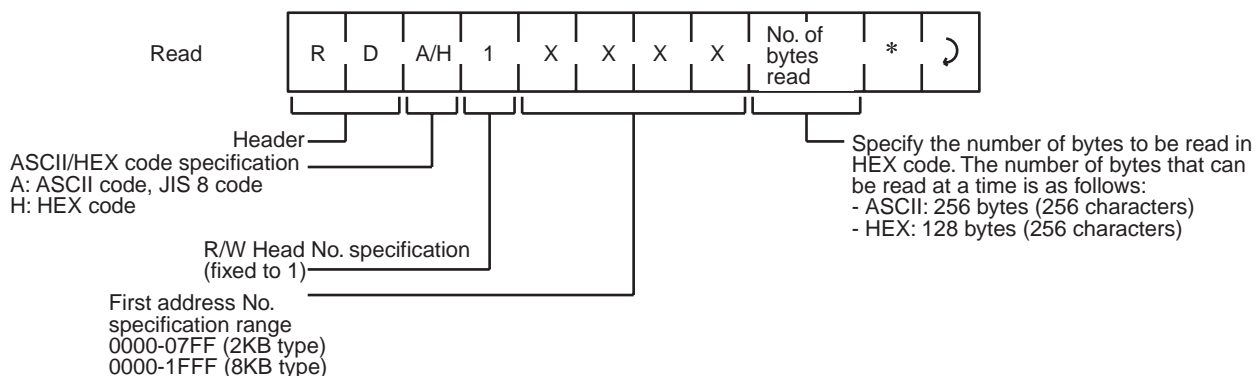

#### Response Format

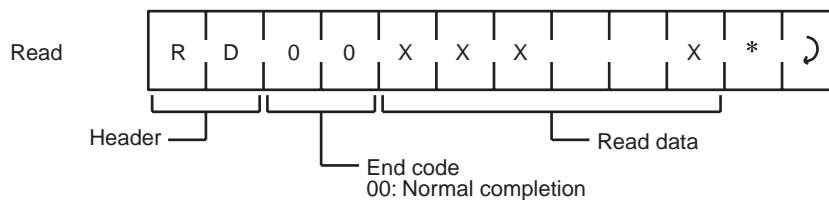

**Note** If the Data Carrier is missing, "RD72" is returned.

### 4-4-2 Write (WT)

Writes data to the Data Carrier. If the Data Carrier is missing, an error response (end code: 72 = Data Carrier missing) is returned.

#### Command Format

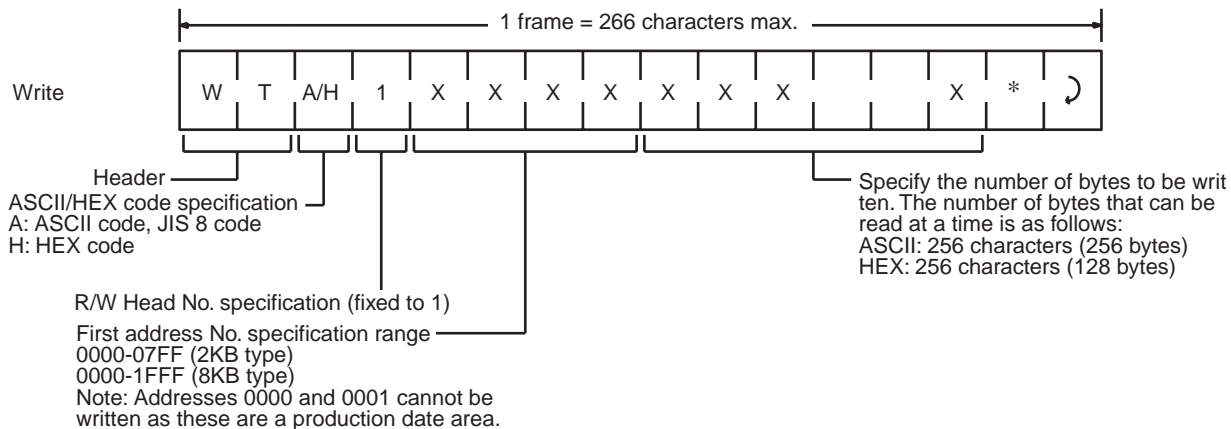

#### Response Format

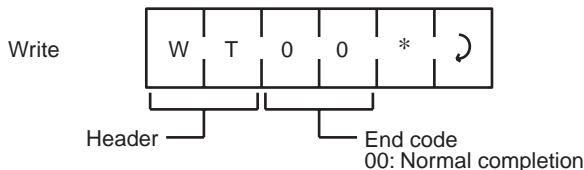

**Note** If the Data Carrier is missing, "WT72" is returned.

### 4-4-3 Expansion Read Command (XR)

Performs batch read processing of up to 2 KB. The processing procedure to the DC is the same as that of the read command.

#### Command Format

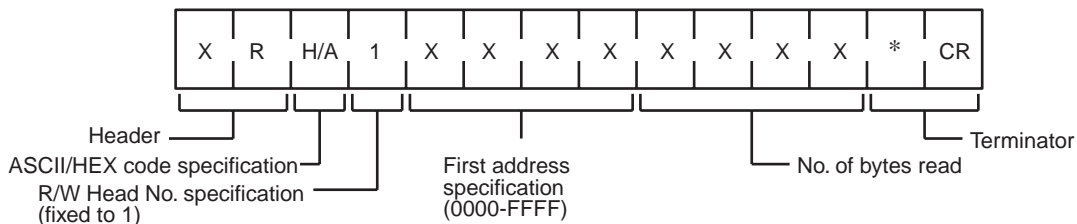

#### Response Format

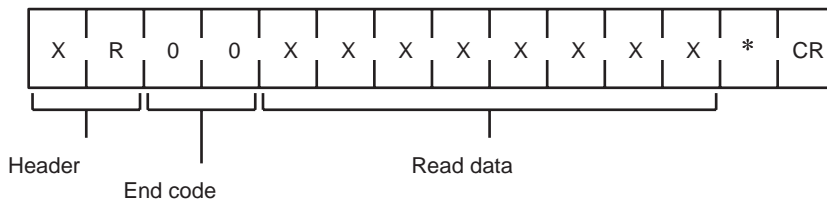

If the number of characters of read data is greater than 250, the frame is divided as follows:

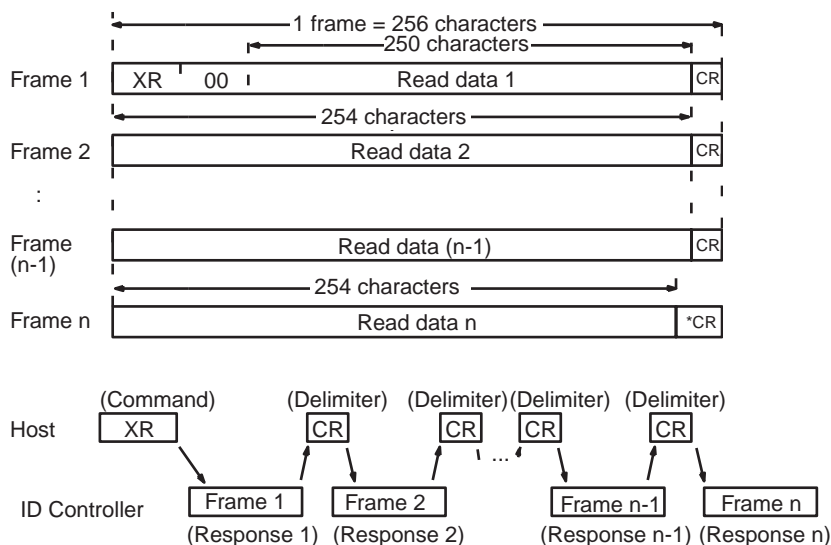

### 4-4-4 Expansion Write Command (XW)

Performs batch write processing of up to 2 KB. The processing procedure to the DC is the same as that of the write command.

#### Command Format

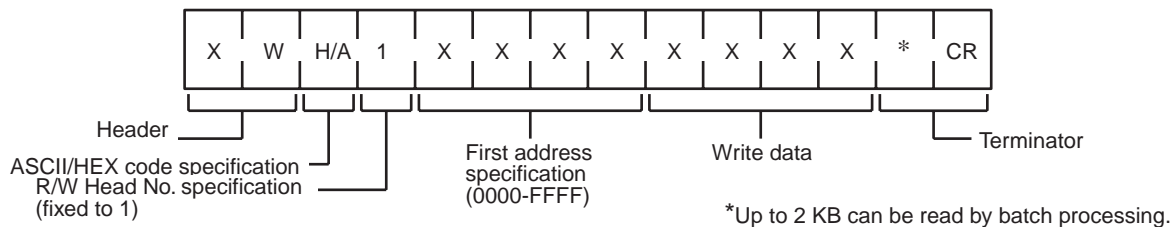

#### Response Format

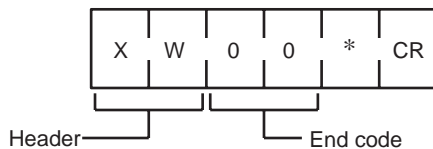

If the command length is greater than 266 characters, divide the frame.

#### Frame Division

- 1,2,3...**
1. Divide the frame so that each frame consists of up to 266 characters.
  2. Append a terminator (\*CR) only to the last frame (frame n). Append a delimiter (CR) at the end of the other frames.
  3. A header, ASCII/HEX specification, head no. specification, and first address are necessary for the first frame (frame 1). If one of these is missing, a command input error occurs. The write data can be omitted.
  4. If the HEX code is specified, the number of write data characters in each frame must be even. If it is odd, a command input error occurs.
  5. Divide the frame so that the last frame is not AA\*CR or XZ\*CR.



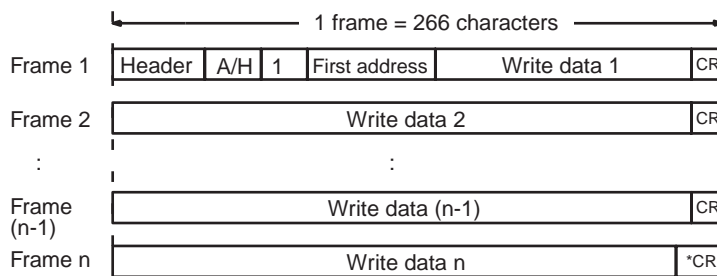

(Communication procedure)

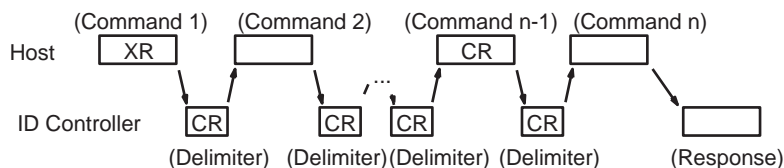

### 4-4-5 Auto Read (AR)

Reads data when the Data Carrier has approached. The ID Controller responds when the lower communication has ended.

#### Command Format

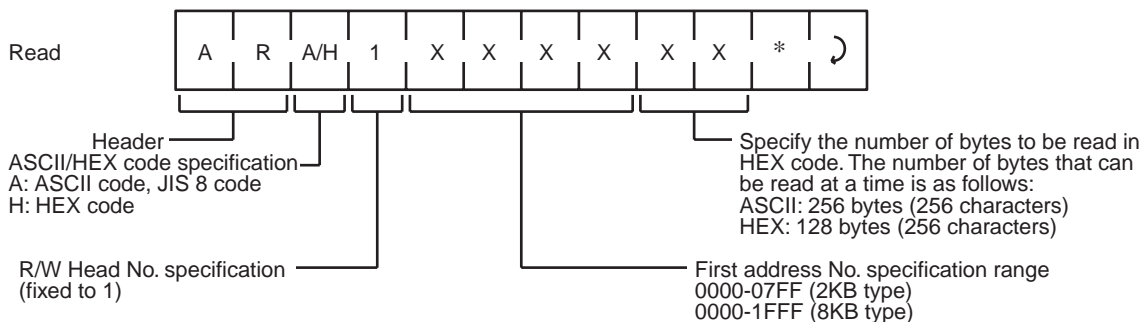

#### Response Format

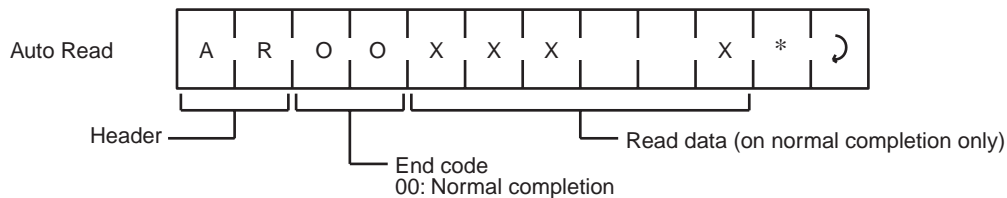

### 4-4-6 Auto Write (AW)

Writes data when the Data Carrier has approached. The ID Controller responds when the lower communication has ended.

#### Command Format

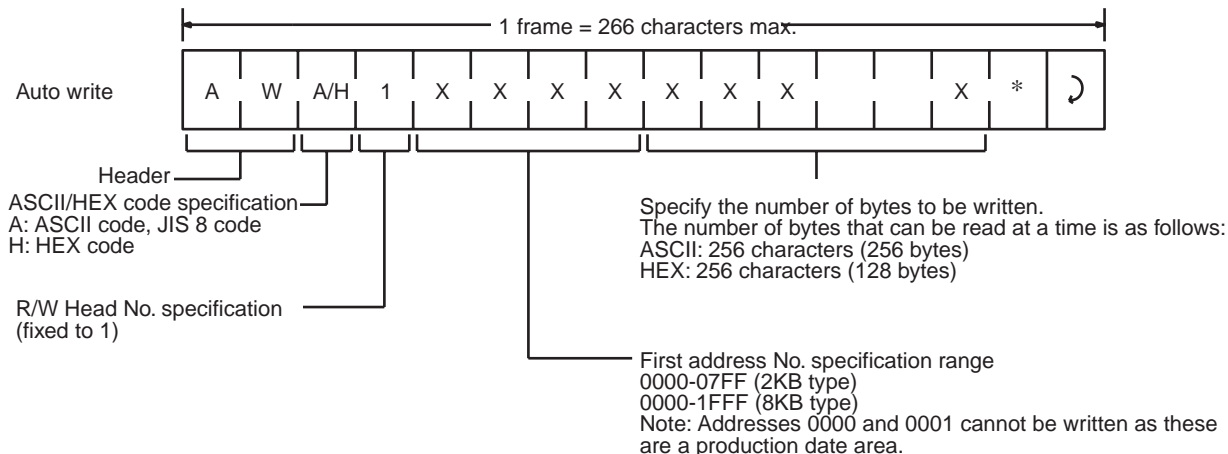

#### Response Format

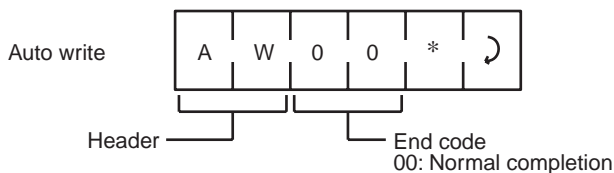

### 4-4-7 Polling Auto Read (PR)

When the host computer transmits the polling auto command, the ID Controller immediately responds, indicating the reception of the command. After this, the ID Controller reads data when the Data Carrier approaches. Meanwhile, the host computer can make an inquiry on the result of the command processing by using a subcommand.

#### Command Format

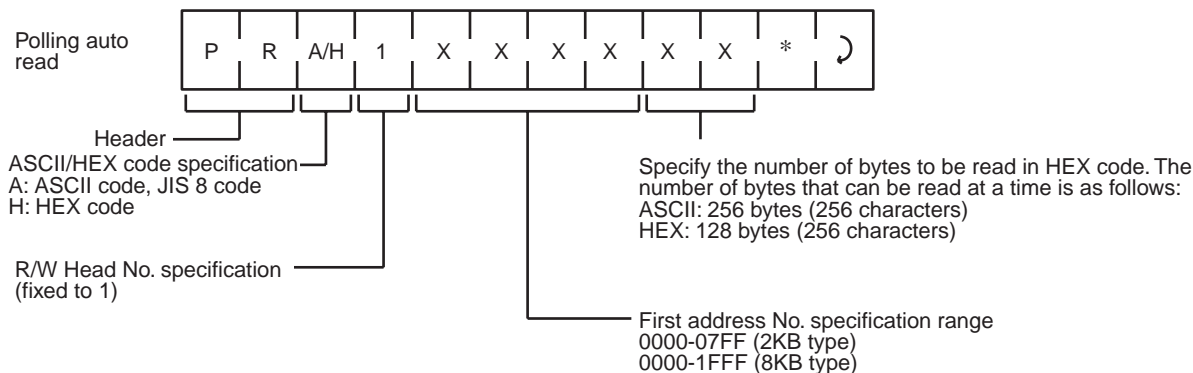

#### Response Format

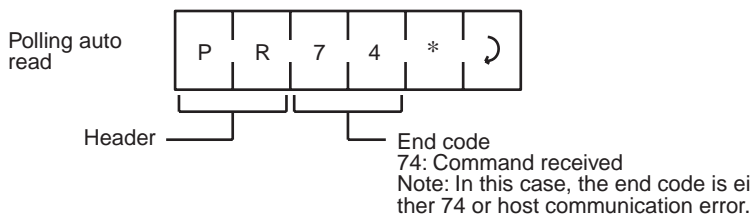

**Subcommand Format**

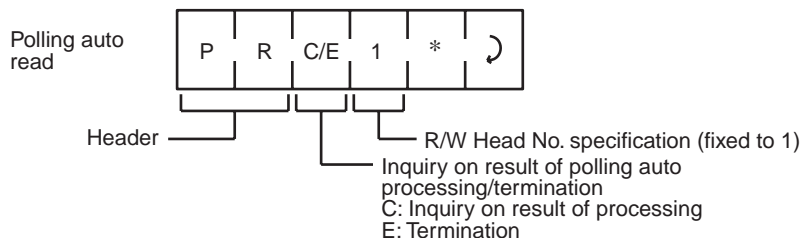

**Subcommand Response Format**

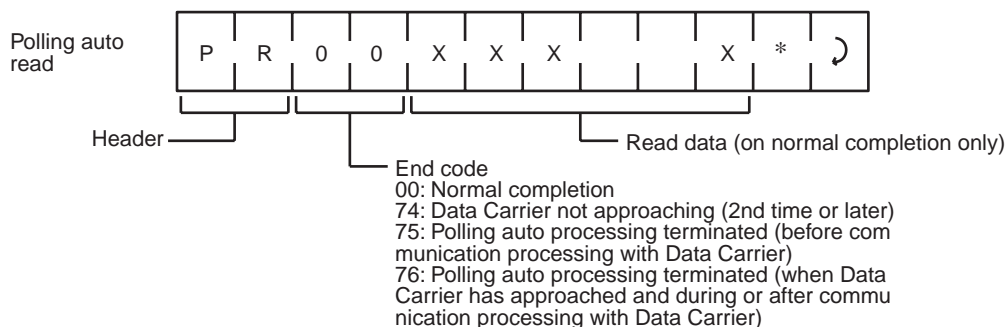

**4-4-8 Polling Auto Write (PW)**

When the host computer transmits the polling auto command, the ID Controller immediately responds, indicating the reception of the command. After that, the ID Controller writes data when the Data Carrier approaches. Meanwhile, the host computer can make an inquiry on the result of the command processing by using a subcommand.

**Command Format**

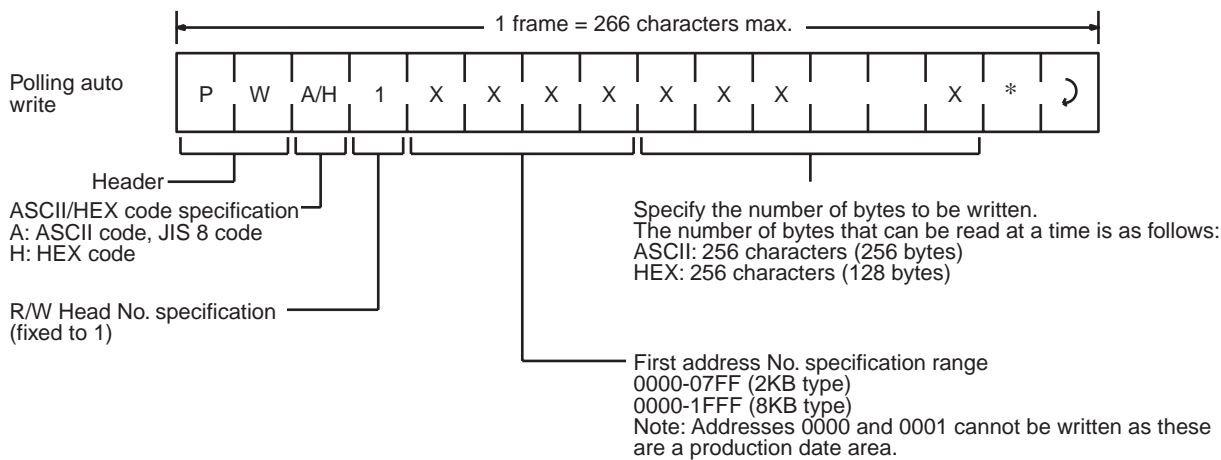

**Response Format**

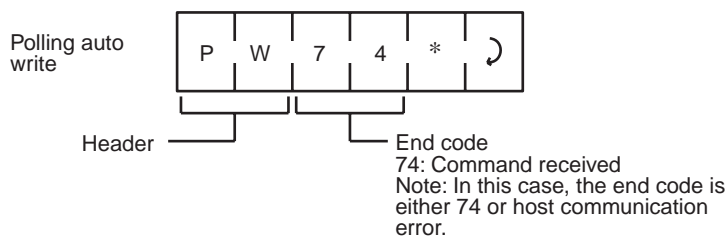

### 4-4-9 Command Processing Terminating Command (AA)

Terminates the processing of the commands other than the polling commands and restores the command wait status. Can also terminate the communication of frames of an expansion command.

#### Command Format

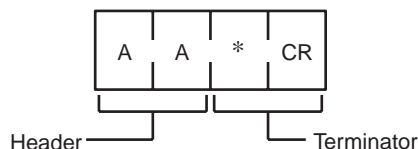

#### Response Format

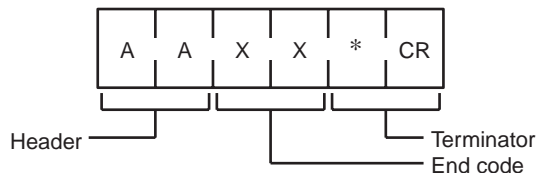

End code	Meaning
14	Processing of auto or ordinary command is not executed.
75	Expansion command has not been received yet, sync input has not become active yet, or command execution has been terminated before DC is detected.
76	When DC read/write processing is terminated.

### 4-4-10 Data Check Command (MD C/K)

Writes a CRC code and executes data collation in a check block specified by the user. A CRC code is calculated with the generating function  $X^{16} + X^{12} + X^5 + 1$ . The number of check block bytes required is the number of bytes of the check code calculation area plus two bytes. Refer to 5-5 *Checking Function of the Data Carrier's Memory* for details.

#### 1-to-1 Procedure

##### Command Format

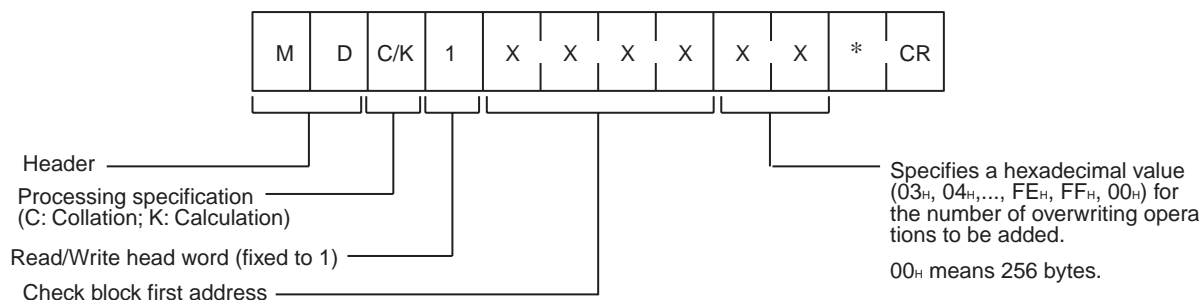

##### Response Format

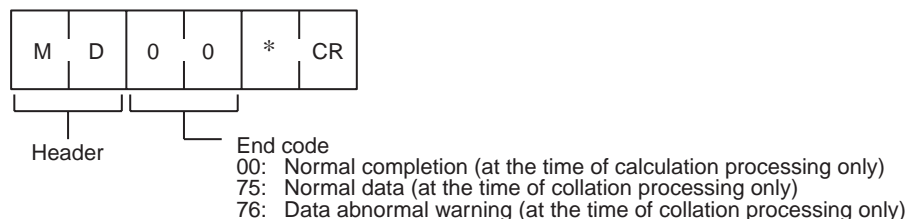

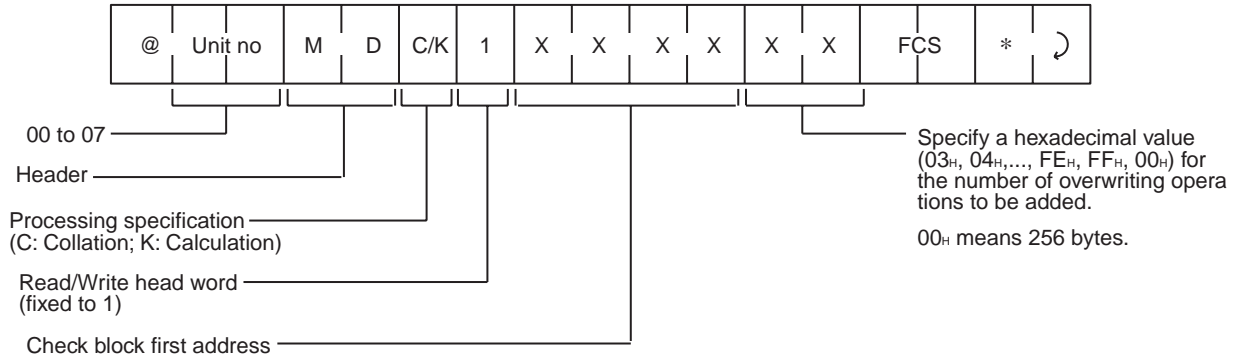
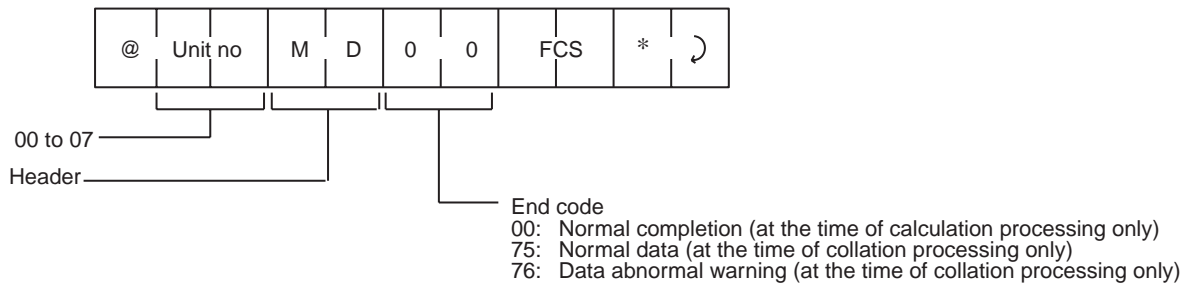
**1-to-n Procedure****Command Format****Response Format****4-4-11 Data Management Command (MDS/MDL)**

The MDL and MDS commands can be used to check the number of overwriting operations for the EEPROM in an EEPROM-type Data Carrier. By adding or subtracting a number of writing operations to the number in the management area specified by the user, it is possible to check whether or not the number of overwriting operations has exceeded the allowable number. Refer to 5-4-2 EEPROM-type Data Carrier for details.

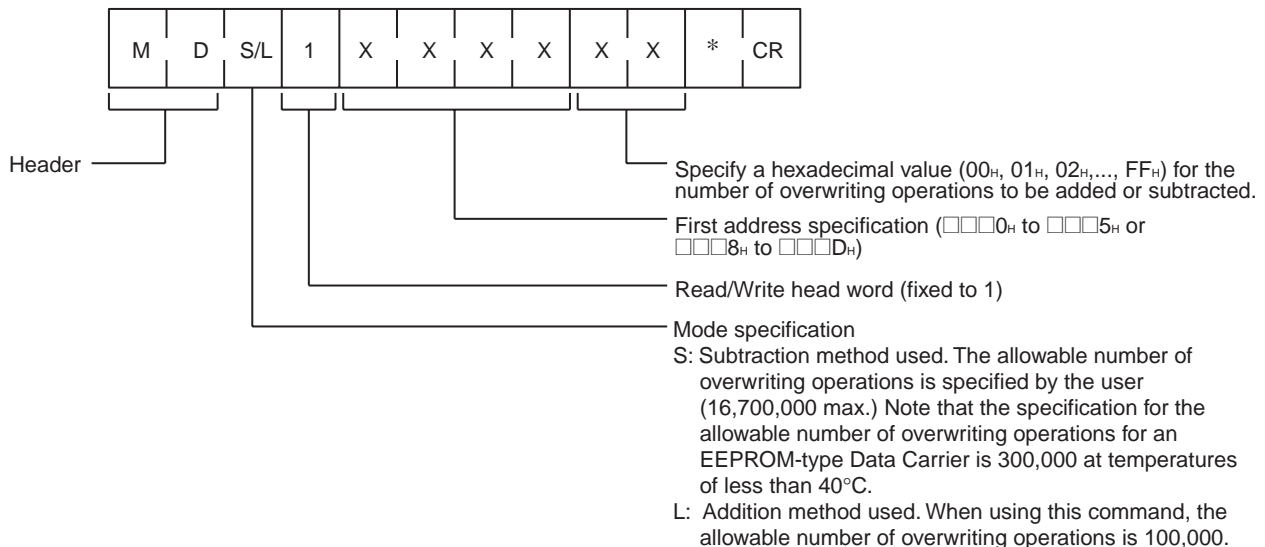
**1-to-1 Procedure****Command Format**

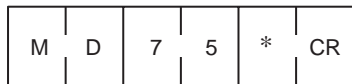
**Response Format**

Header

End code

75: The number of overwriting operations has not exceeded the allowable number.

76: The number of overwriting operations has exceeded the allowable number.

**1-to-n Procedure****Command Format**

00 to 07

Header

Specifies a hexadecimal value (00<sub>H</sub>, 01<sub>H</sub>, 02<sub>H</sub>,..., FF<sub>H</sub>) for the number of overwriting operations to be added.

First address specification

Read/Write head word (fixed to 1)

Mode specification

S: Subtraction method used. The allowable number of overwriting operations is specified by the user (16,700,000 max.) Note that the specification for the allowable number of overwriting operations for an EEPROM-type Data Carrier is 300,000 at temperatures of less than 40°C.

L: Addition method used. When using this command, the allowable number of overwriting operations is 100,000.

**Response Format**

00 to 07

Header

End code

75: The number of overwriting operations has not exceeded the allowable number.

76: The number of overwriting operations has exceeded the allowable number.

**4-4-12 Write Processing Repeat Command (RP)**

Executes the processing the write command previously executed.

**Command Format**

Header

Terminator

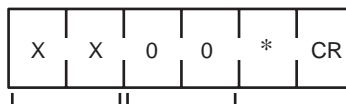
**Response Format**R/W Head No. specification  
(fixed to 1)ASCII/HEX code specification  
A: ASCII code, JIS 8 code  
H: HEX code

The write command information is cleared under the following conditions:

- When the Controller is power-reset.
- When a host communication error occurs during execution of write command
- If the repeat command is executed in this status, a command input error occurs.

### 4-4-13 Controller Control Command (CC)

Manipulates/reads I/O.

#### Command Format

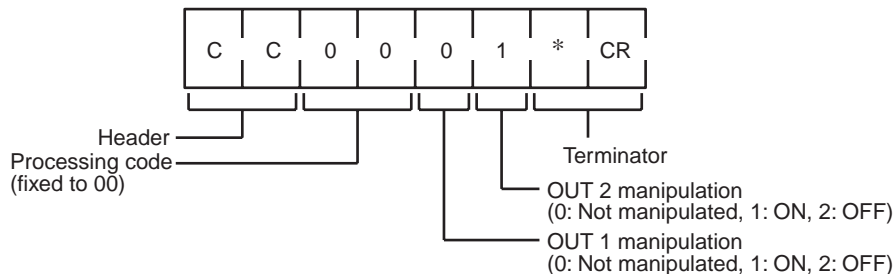

#### Response Format

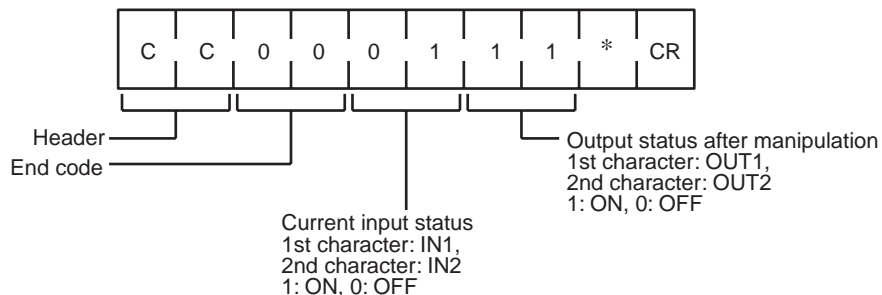

### 4-4-14 Error Information Read Command (CF)

Reads the latest error log information.

#### Command Format

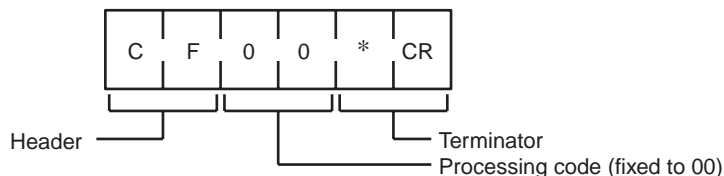

#### Response Format

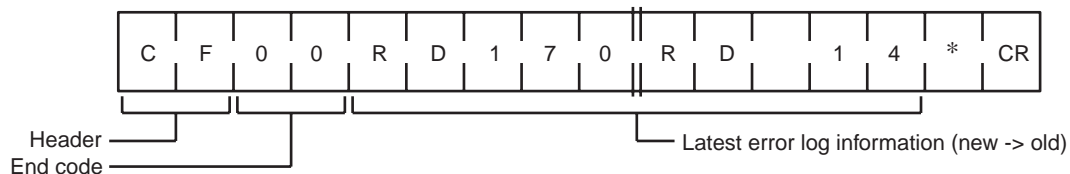

The latest error log information is arranged in the order of occurrence and five characters indicate one error.

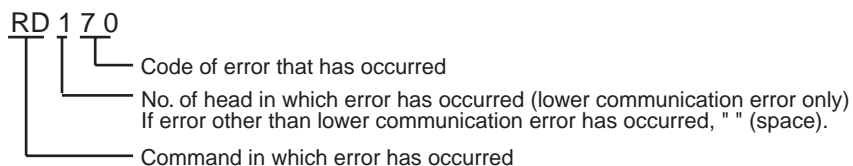

**Note** The error log information is cleared by means of power reset. If this command is executed in this status, no error log information is read.

### 4-4-15 Test Command (TS)

Returns a test message sent from the host computer as is. The test command is used to test communication between the host computer and the ID Controller.

#### Command Format

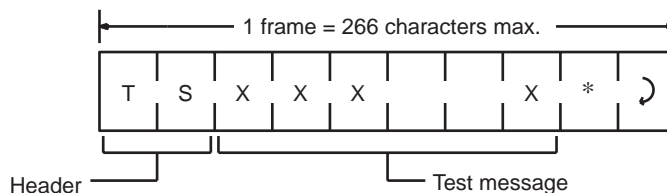

#### Response Format

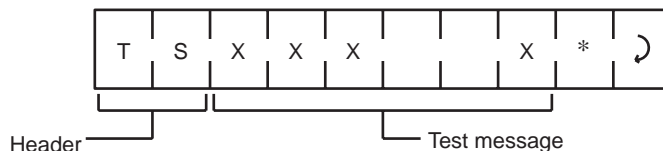

### 4-4-16 Abort Command (XZ)

If the ID Controller does not return a response due to a problem during the host communication or lower communication, the abort command can restore the ID Controller to the command wait status. There is no response to the abort command.

#### Command Format

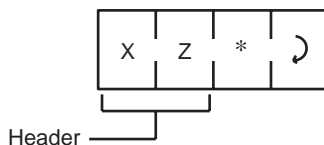

**Note** The ID Controller requires about 100 ms to get ready for reception of the next command after it has received the abort command.



### 4-4-17 Command Undefined Response (IC)

This is a response the ID Controller returns if it cannot read the header of a given command.

#### Response Format

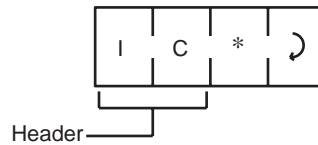

### 4-4-18 Error Response

If an error occurs during the host communication or lower communication, the error is identified by the end code.

#### Response Format

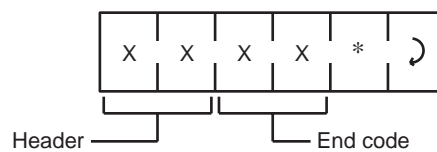

The header same as that of the transmitted command

### 4-4-19 End Code List

The end code is expressed as a 2-digit hexadecimal number.

Type	End code	Name
Normal	00	Normal completion
	7B	Warning: Data Carrier battery end
	74	Polling command reception Data Carrier not approaching (when polling inquiry command is issued)
	75	Termination of command before processing (Termination before execution of read/write processing of data)
	76	Termination of command after processing (Termination after execution of read/write processing of data)
Host communication	10	Parity error
	11	Framing/overflow error
	14	Command input error
	18	Frame length MAX error
Lower communication	70	Data Carrier communication error
	71	Unmatching error
	72	Data Carrier missing
	7A	Address over
	7C	R/W head not connected
	7D	Write protect error

## 4-5 Example of Communications Program

### Host Link Serial System

#### Example of System Configuration

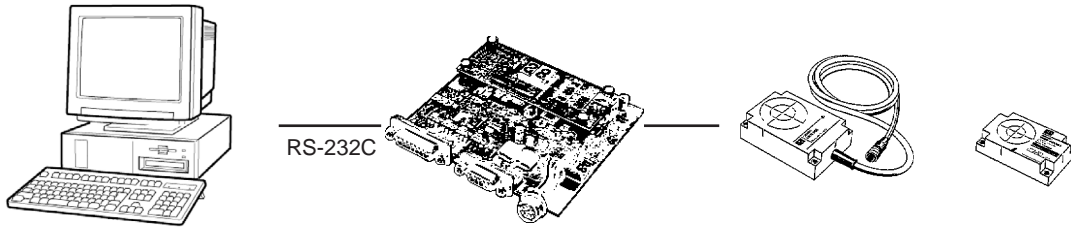

#### Example of BASIC Program

In this example, data is written from Data Carrier 1 as HEX code by the write command. Input the write address in four characters in the range of 0006 to 1FFF, and write data as 2-digit HEX characters. The total character length of the write data must be 256 or less. Set the communication format of the ID Controller by using the DIP switches in accordance with the communication system of the host computer to be used.

```

10  CLS
20  OPEN "COM1:9600,E,8,1,CS0,DS0,CD0,PE" AS#1
30  WIDTH #1.255
40  PRINT "write command is executed"
50  INPUT "write address (HEX data: 0006-01FF)"=WA$
60  INPUT "write data (HEX data: 2-digit units)":WD$
70  TX$="WTH1"+WA$+WD$+"*"+CHR$(&HD)
80  PRINT TX$
90  PRINT #1, TX$;
100 INPUT #1, RX$
110 PRINT "RS data=":RX$
120 GOTO 40

```

**Note** The above program is for IBM-PC. The program differs depending on the host computer to be used.

## 4-6 Communication Time

The time required for communications varies with the DC memory type (SRAM or EEPROM). Furthermore, if the memory is EEPROM, communications time varies with the slave communications mode setting. The communications time consists of TAT (turn around time) and slave communications time. TAT is the time required for the host computer to receive a response after it has finished sending a command. Slave communications time is the time required for communications between the R/W Head and DC and is exclusive of host communications time. Slave communications time is used as a reference when calculating the moving speed of an auto command.

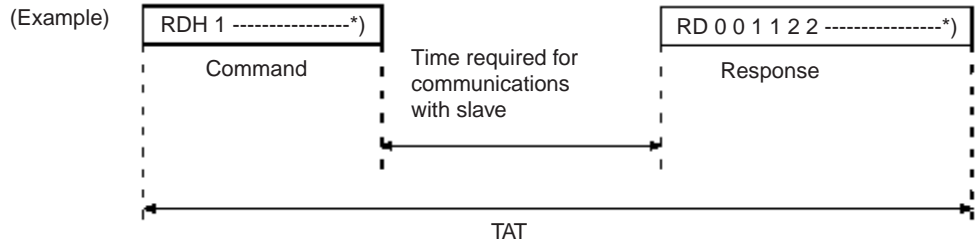

### 4-6-1 Communication Time

#### S-RAM DC (Reference)

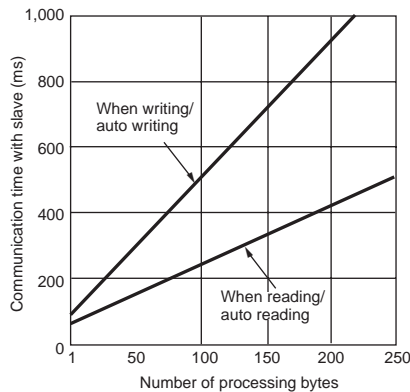

Formula (msec)

	Communication Time
Read	$T = 1.8 N + 48.4$
Write	$T = 4.2 N + 86.5$

N: Number of processing bytes

#### EEPROM (Reference)

#### Communication Distance Priority mode

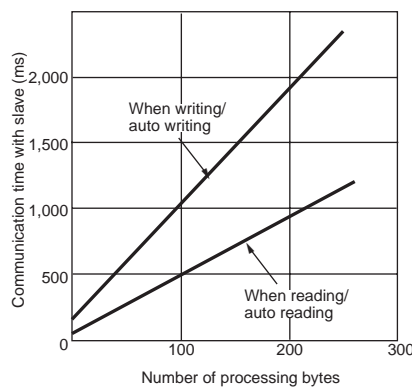

Formula (msec)

	Communication Time
Read	$T = 4.3 N + 64.6$
Write	$T = 8.7 N + 167.1$

N: Number of processing bytes

EEPROM (Reference)

Communication Time Priority mode

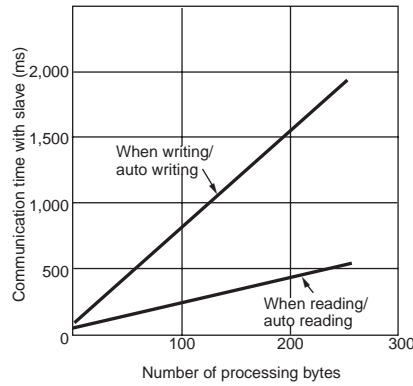

Formula (msec)

	Communication Time
Read	$T = 1.8 N + 79.0$
Write	$T = 7.1 N + 180.4$

N: Number of processing bytes

4-6-2 TAT (Turn Around Time)

S-RAM DC (Reference)

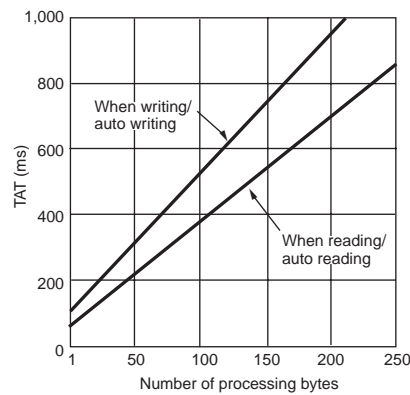

Formula (msec)

	TAT
Read	$T = 2.9 N + 69.8$
Write	$T = 5.3 N + 105.6$

N: Number of processing bytes

EEPROM (Reference)

Communication Distance Priority mode

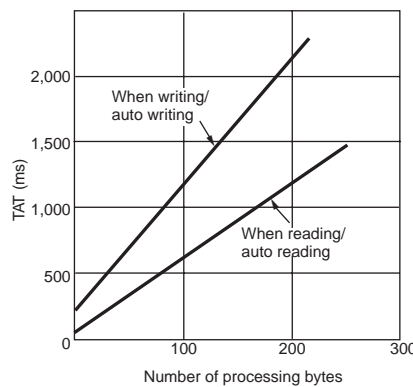

Formula (msec)

	TAT
Read	$T = 5.4 N + 85.4$
Write	$T = 9.8 N + 184.9$

N: Number of processing bytes

EEPROM (Reference)

Communication Time Priority mode

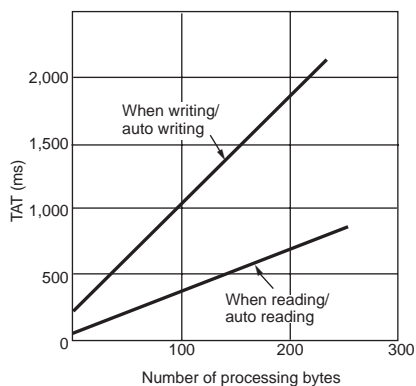

Formula (msec)

	TAT
Read	$T = 2.9 N + 99.1$
Write	$T = 8.2 N + 272.9$

N: Number of processing bytes

- Note**
- (1) The TAT data values are for a host communications speed set to 9,600 bps with 8-bit length, 1 stop bit, and odd parity. The data is sent continuously with no spaces.
  - (2) The number of TAT data bytes is the number of code-designated ASCII bytes.

# SECTION 5

## Testing

This section provides the information required to test and maintain the performance of the RFID System.

5-1	Test Run .....	52
5-2	Diagnostics .....	53
5-3	Error Lists .....	54
5-4	Checking the Data Carrier Life .....	55
5-4-1	SRAM-type Data Carrier .....	55
5-4-2	EEPROM-type Data Carrier .....	56
5-5	Checking Function of the Data Carrier's Memory .....	59
5-6	Troubleshooting .....	62
5-7	Maintenance and Inspection .....	63
5-8	Systems Check .....	64

## 5-1 Test Run

### Checklist

No.	Item	Criteria
1	Connection of power and I/O lines	Is the wiring correct? Are all terminals tightly secured?
2	Setting of DIP switches	Are communication specifications correctly set?
3	Connection of R/W Head	Is R/W Head correctly connected?
4	Location of data carrier	Are data carrier and R/W Head correctly located?
5	Connection of host computer	Is the RS-232C connector correctly connected?
6	Trigger condition	Is the input condition of trigger correctly set?

### Procedure of Test Run

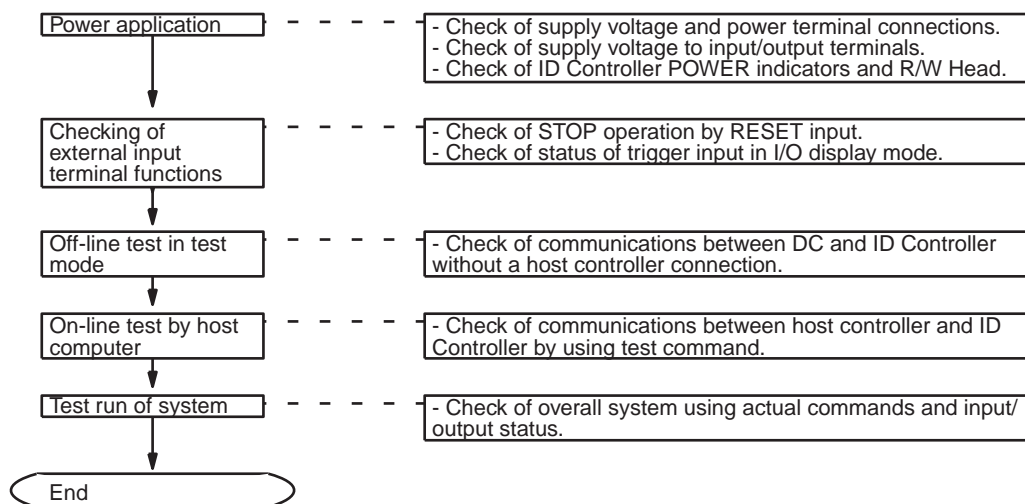

### Off-line Test in Test Mode

By setting the Test Mode, communication between the ID Controller and DC can be tested without the Controller being connected to the host computer.

Use this test to check mounting positions before the test run.

### Communications Test with Host Computer

Communications testing between the ID Controller and the host computer can be performed by using the test command, so that connections of the cables and communications operation can be checked before the test run of the overall system.

- 1,2,3...**
1. Create a simple communications program on the host computer and transmit the test command (TS).
  2. If the communication system is normal, the ID Controller returns the test data it has received as is.

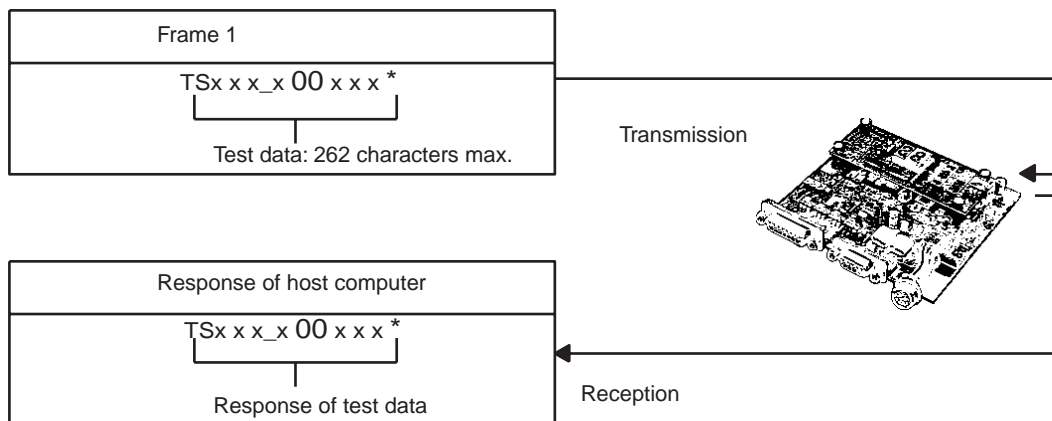

## 5-2 Diagnostics

### Errors

**Errors that Stop Operation** If a hardware error of the ID Controller has occurred, the STOP indicator lights, and RUN output is turned OFF.

**Errors that Allow Operation to Continue** If an error has occurred during communications between the ID Controller and the host computer, or between the Controller and the R/W Head, the error code is displayed on the monitor (error code display mode). Up to 30 error codes are recorded and can be read by the host controller.

### Indicators and Outputs

Status		Indicator			Monitor	Output			
		POWER	HEAD	STOP		RUN	End of processing	User 1	User 2
Test	Lower processing in progress	Lit	Lit	Not lit	---	OFF	OFF	---	---
	Lower processing interval	Lit	Not lit	Not lit	---	OFF	OFF	---	---
	Communication error occurrence	Lit	Not lit	Not lit	Error code	OFF	OFF	---	---
RUN	Command reception wait	Lit	Not lit	Not lit	---	ON	OFF	---	---
	Command processing in progress	Lit	Lit	Not lit	---	ON	OFF	USR	USR
	Communication error occurrence	Lit	Not lit	Not lit	Error code	ON	ON	---	---
Stop error	CPU error	Lit	Not lit	Lit	92	OFF	OFF	---	---
	Memory error	Lit	Not lit	Lit	93	OFF	OFF	---	---
Emergency stop	External reset input ON	Lit	---	Lit	---	OFF	OFF	---	---

**Note** USR: Set by the controller control command.



## 5-3 Error Lists

### Communication Error

Location	Error code	Type	Condition
Host communication error	10	Parity error	Error occurs during communication between host computer and ID Controller. – Incorrect setting of communication format – Malfunctioning due to noise
	11	Framing error	
	12	Overrun error	Wrong command format. Command or data length exceeding 266 characters.
	14	Command input error	
	18	Frame length MAX error	
Lower communication error	70	Data carrier communication error	Error during communication between R/W Head and DC. – Setting error such as passing speed and distance – Malfunctioning due to obstacle
	71	Unmatching error	Read or write processing is not performed correctly.
	72	Data carrier missing	DC does not exist in specified area when write/read command is executed.
	7A	Address over	Address exceeding memory area of DC is specified. When using MDS/MDL command, first address of the area is incorrectly specified.
	7C	R/W head not connected	R/W Head is not connected.
	7D	Write protect error	Production date area or write-protected area is specified for write command.

- Note**
1. The host communication error is an error that has occurred during communications between the host computer and ID Controller.
  2. The lower communication error is an error that has occurred during communications between the ID Controller and R/W Head. These errors are all recorded in the ID Controller and their error codes and messages can be read using a command from the host computer.
  3. These errors are all recorded in the ID Controller and their error codes can be read using a command from the host computer.

### Warning Code

Warning Code	Name	Meaning
7B	Data carrier battery low	The voltage of the Data Carrier's built-in battery is low.
76	Excessive number of Data Carrier overwriting operations	This warning will be returned when the data management command (MDS/MDL) is executed if the number of Data Carrier overwriting operations is 100,000 or over.
76	Data Carrier memory check error	This warning will be returned if a memory error is detected when the memory check command (MDC) is executed.

### System Error

Error code	Type	Condition
92	CPU error	May be due to an ID Controller error or the influence of noise. Turn OFF power once and then turn it back ON again. Turn ON the reset input (if the error still persists, use the other ID Controller).
93	Memory error	

- Note** The system error (error that stops the operation) can be displayed on the monitor of the ID Controller but cannot be checked by the host computer.

## 5-4 Checking the Data Carrier Life

### 5-4-1 SRAM-type Data Carrier

#### Checking Battery Voltage Drop

- 1,2,3...
1. A voltage drop of the battery cannot always be checked but can be checked only when specific access is made. This is because, to check the battery voltage, a certain amount of current is temporarily allowed to flow through the internal circuit of the data carrier. If the battery voltage is checked each time the data carrier is accessed, the battery life is shortened. It is recommended that a routine that checks the battery once a day be incorporated in the system program.
  2. Access to check battery voltage:  
The battery is checked only when the 2-byte data of addresses 0000 and 0001 are read.  
<Battery voltage check command>
    - a) Read command ... RD H 1 0000 02
    - b) Auto read command ... AR H 1 0000 02
    - c) Polling auto read ... PR H 1 0000 02
    - d) Expansion read command ... XR H 1000 02
  3. Response when battery voltage drops:  
If the battery voltage has dropped, "7B" is returned as the end code of a response.

Example:

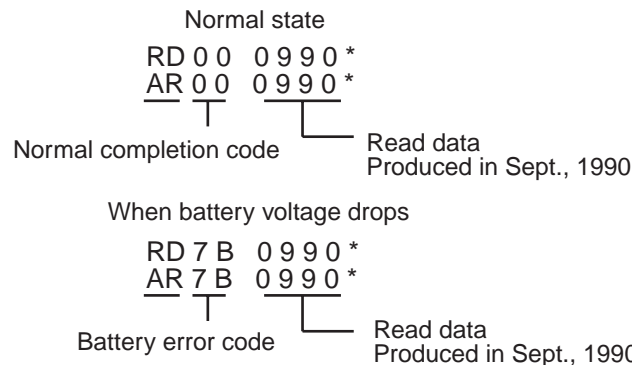

#### Battery Life of the Data Carrier After Battery Voltage Drop

The Data Carrier can still be used for about 1 month under ordinary operating conditions, even if the voltage of the battery has dropped below the rated level. However, it is recommended that the Data Carrier be replaced with a new one as soon as possible.

The battery-replaceable V600-D2KR16 can still be used for about 2 weeks under ordinary operating conditions, even if the voltage of the battery has dropped below the rated level. However, it is recommended that the battery be replaced with a new one as soon as possible.

**Note** SRAM-type Data Carriers (excluding the V600-D2KR16) have a built-in thionyl chloride lithium battery. Due to the characteristics of thionyl chloride lithium batteries, the internal resistance of the battery increases when it is unused for several months. If the battery voltage drop is checked on a Data Carrier in this condition, a voltage drop will result even though the battery life is still satisfactory. This phenomenon is due to the increase in the internal

resistance, and does not indicate that the battery life is over. Accordingly, if a Data Carrier is purchased and left unused for several months, activate the battery by performing a read operation for about 10 minutes. (Activating the battery in this way will run current through it, which will return the internal resistance to its normal state. This will have almost no effect on the battery life.)

### 5-4-2 EEPROM-type Data Carrier

The MDL and MDS commands can be used to check whether or not the number of overwriting operations for the EEPROM in an EEPROM-type Data Carrier has exceeded the allowable number.

The MDS command subtracts the number of overwriting operations from a user-specified management area and makes it possible to check whether or not the number of overwriting operations has exceeded a user-specified number.

The MDL command adds the number of overwriting operations to a user-specified management area and makes it possible to check whether or not the number of overwriting operations has exceeded 100,000. This command is for EEPROM-type Data Carriers with a specification of 100,000 for the allowable number of overwriting operations.

**Note** The MDS command can be used only with version 2.1 or later. Refer to page 12 for details on the method used to check the version.

#### Command Format

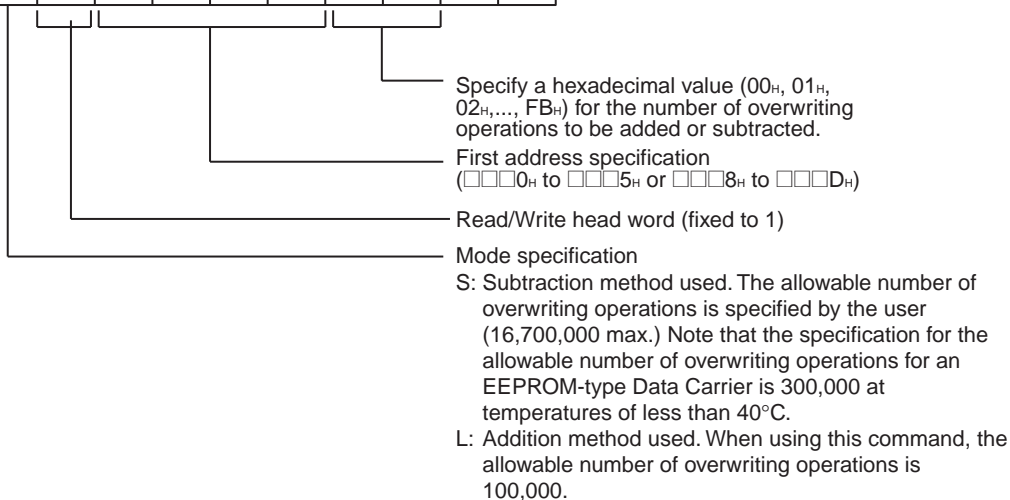
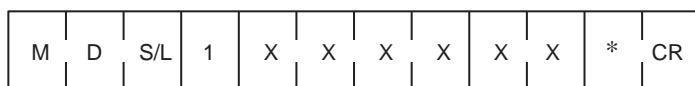

#### Response Format

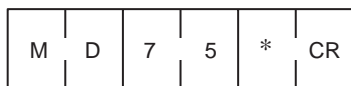

End code  
 75: The number of overwriting operations has not exceeded the allowable number.  
 76: The number of overwriting operations has exceeded the allowable number.

- Note**
1. The first address must be □□□0<sub>H</sub> to □□□5<sub>H</sub> or □□□8<sub>H</sub> to □□□D<sub>H</sub>. Do not specify □□□6<sub>H</sub> to □□□7<sub>H</sub> or □□□E<sub>H</sub> to □□□F<sub>H</sub> as the first address, otherwise address error code 7A (hexadecimal) will be returned.
  2. The unit number is required for 1-to-n procedure.

**MDS Command**

The management area consists of three bytes beginning with the first address of the area. When the MDS command is executed, the specified number of overwriting operations is subtracted from the present number and the result is written to this area. If it is 0 (00<sub>H</sub>), end code 76 will be returned as a warning. It is necessary to specify the allowable number of overwriting operations beforehand. This can, in theory, be set to any number up to 16,700,000 but the specification for the allowable number of overwriting operations for an EEPROM-type Data Carrier at temperatures of less than 40°C is 300,000 (0493E0<sub>H</sub>) so set to a number less than this. The number of overwriting operations up to the present time is written in the management area as hexadecimal data. The data can also be read using the read command.

If the number of overwriting operations in the management area is already 0, the hexadecimal data value will not be renewed. In this case, only the warning will be returned when the MDS command is executed. If the MDS command is executed with 00<sub>H</sub>, nothing will be written to the hexadecimal data but the number of overwriting operations up to the present time can be checked.

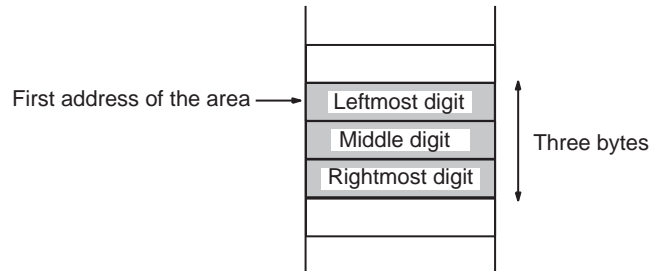

**MDS Command Execution Example**

In the following example, three bytes beginning with address 0010<sub>H</sub> are specified as the management area for overwriting operations.

1,2,3...

1. Input 300,000 overwriting operations with WTH100100493E0.

0010 <sub>H</sub>	04 <sub>H</sub>
0011 <sub>H</sub>	93 <sub>H</sub>
0012 <sub>H</sub>	E0 <sub>H</sub>

2. Input 5 overwriting operations with MDS1001005.

0010 <sub>H</sub>	04 <sub>H</sub>
0011 <sub>H</sub>	93 <sub>H</sub>
0012 <sub>H</sub>	DB <sub>H</sub>

3. The following indicates that the number of overwriting operations is 300,000. MD76 will be returned to indicate an excessive number of overwriting operations if MDS1001000 is executed.

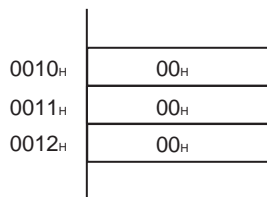

**Note** Do not use MDS and MDL commands together in a Data Carrier. Doing so would disable lifetime management.

**MDL Command**

The management area consists of three bytes beginning with the first address of the area. When the MDL command is executed, the specified number of overwriting operations is added from the present number and the result is written to this area. If it is 100,000 (0186A0<sub>H</sub>) or over, end code 76 will be returned as a warning. The number of overwriting operations up to the present time is written in the management area as hexadecimal data. The data can also be read using the read command.

If the number of overwriting operations in the management area is already 100,000 or over, the hexadecimal data value will not be renewed. In this case, only the warning will be returned when the MDL command is executed. If the MDL command is executed with 00<sub>H</sub>, nothing will be written to the hexadecimal data but the number of overwriting operations up to the present time can be checked.

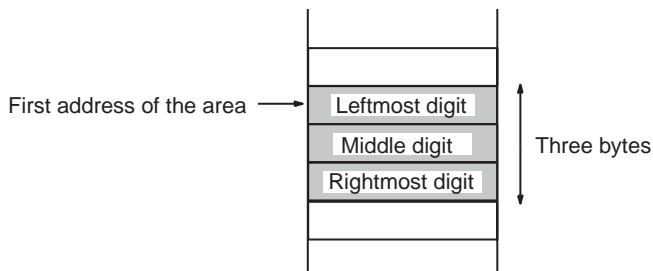

**MDL Command Execution Example**

In the following example, three bytes beginning with address 0010<sub>H</sub> are specified as the management area for overwriting operations.

- 1,2,3... 1. Clear the management area first with WTH1001000000.

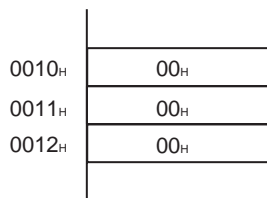

2. Input 4 overwriting operations with MDL1001004.

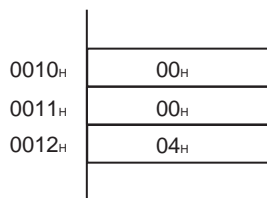

3. Input 5 as the next number of overwriting operations with MDL1001005 make the total overwriting operations 9.

0010 <sub>H</sub>	00 <sub>H</sub>
0011 <sub>H</sub>	00 <sub>H</sub>
0012 <sub>H</sub>	09 <sub>H</sub>

4. The following indicates that the number of overwriting operations is 100,000. MD76 will be returned to indicate that an excessive number of overwriting operations will result if MDL1001000 is executed.

0010 <sub>H</sub>	01 <sub>H</sub>
0011 <sub>H</sub>	86 <sub>H</sub>
0012 <sub>H</sub>	A0 <sub>H</sub>

## 5-5 Checking Function of the Data Carrier's Memory

A Data Carrier memory check is possible by executing the data check command MD. CRC (Cyclic Redundancy Check) code calculation, data writing, and data collation are possible in a check block specified by the user. A CRC code is calculated with the generating function  $X^{16} + X^{12} + X^5 + 1$ .

### Command Format

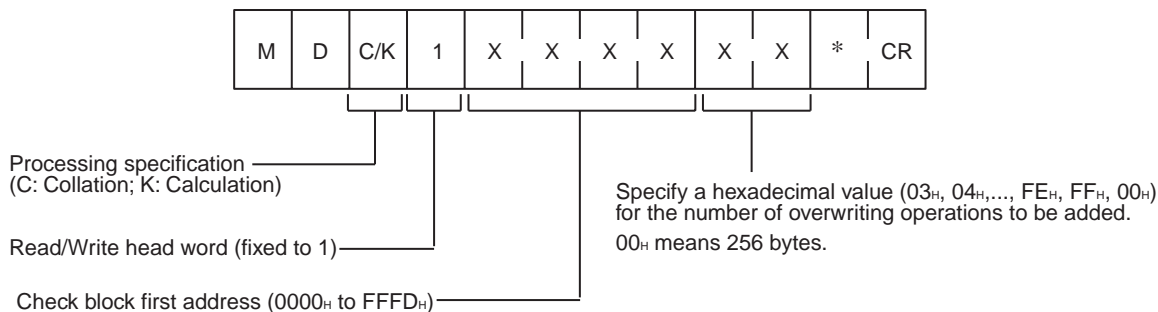

### Response Format

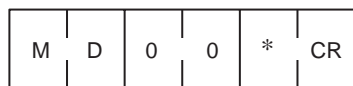

**Note:** The unit number is required for 1-to-n procedure(s).

- End code  
 00: Normal completion (at the time of calculation processing only)  
 75: Normal data (at the time of collation processing only)  
 76: Data abnormal warning (at the time of collation processing only)

In each check block consisting of the first address and the number of bytes specified by the user, the area excluding the last two bytes is the calculation area and the last two-byte area is the check code area of the check block.

If check code write processing is specified with processing code K, the CRC of the data in the calculation area is calculated and the result is written to the check code area. If data collation is specified with processing code C, the CRC of the data in the calculation area is calculated and the result is compared with the data in the check code area. If the result coincides with the data in the check code area, end code 75 will be returned. If they do not coincide with each other, end code 76 will be returned as a warning.

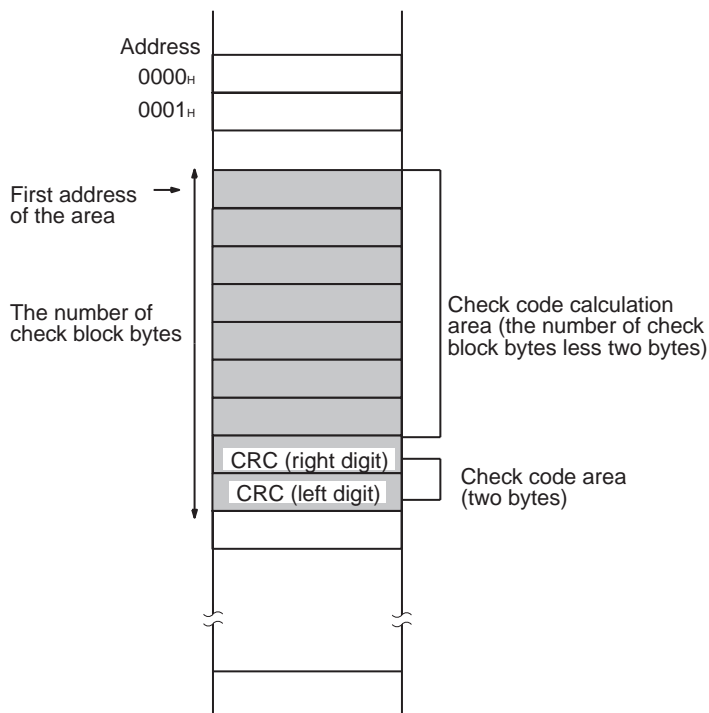

**Data Carrier Memory Check Command Example**

In the following example, the data in addresses 0010<sub>H</sub> to 0012<sub>H</sub> are checked on condition that the following data exists in these addresses.

0010 <sub>H</sub>	12 <sub>H</sub>
0011 <sub>H</sub>	34 <sub>H</sub>
0012 <sub>H</sub>	56 <sub>H</sub>
0013 <sub>H</sub>	
0014 <sub>H</sub>	

- 1,2,3...**
1. Execute MDK1001005 (calculation processing) so that the CRC code (5CD6<sub>H</sub>) of the data "123456" is written to addresses 0013<sub>H</sub> and 0014<sub>H</sub>.

0010 <sub>H</sub>	12 <sub>H</sub>
0011 <sub>H</sub>	34 <sub>H</sub>
0012 <sub>H</sub>	56 <sub>H</sub>
0013 <sub>H</sub>	5C <sub>H</sub>
0014 <sub>H</sub>	D6 <sub>H</sub>

2. Execute MDC1001005 (collation processing). If the result coincides with the data in the check code area, MD75 will be returned as a normal response.

0010 <sub>H</sub>	12 <sub>H</sub>
0011 <sub>H</sub>	34 <sub>H</sub>
0012 <sub>H</sub>	56 <sub>H</sub>
0013 <sub>H</sub>	5C <sub>H</sub>
0014 <sub>H</sub>	D6 <sub>H</sub>

3. If the result does not coincide with the data in the check code area, MD76 will be returned as a warning.



## 5-6 Troubleshooting

The following are the major causes of ID Controller malfunctioning:

Cause	Measures
Influence of noise	Take countermeasures against noise.
Malfunctioning of external devices	Repair is needed.
Malfunctioning of ID Controller	
Others	

### Influence of Noise

If the system malfunctions due to noise, take appropriate countermeasures against noise by referring to the following table:

No.	Occurrence	Possible cause	Countermeasures
1	On power application to motor, transformer, or capacitor.	Momentary voltage drop due to inrush current of large load.	Increase the capacity of the power supply facility or use larger power cables.
		Common mode noise due to the above.	Supply power through 1:1 non-grounded insulated transformer. Do not share the ground lines with other high-capacity loads. Independently ground at less than 100 Ω.
2	Irregular.	Noise superimposed on power lines.	Supply power through 1:1 non-grounded insulated transformer or noise filter.
3	Input signal turns ON when it should be OFF.	Inductive noise of input wiring.	Separate input signal lines from other power lines. If the influence of noise is high, route input lines using a grounded metal conduit or use shielded cables.

#### (1) Improvement of grounding

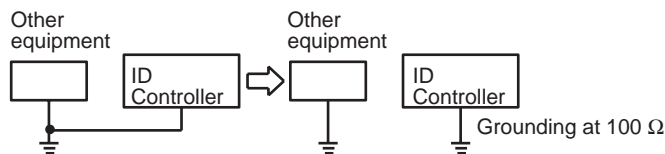

#### (2) Countermeasures against noise

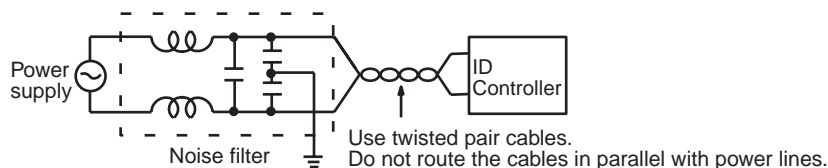

## 5-7 Maintenance and Inspection

To always keep the ID Controller in the best condition, the Controller should be inspected daily or periodically. Although the ID Controller consists of semiconductor devices, without a limited life, the following troubles may occur depending on the environments and conditions in which the ID Controller is operated:

- 1,2,3...**
1. Degradation of elements due to overcurrent and overvoltage.
  2. Degradation of elements due to long-term stress, if the ID Controller is used at high temperatures.
  3. Degradation of insulation and faulty connector contact of due to humidity and dust.
  4. Faulty connector contact or corrosion due to corrosive gas.

### Items of Inspection

No.	Item	Particulars	Criteria	Remarks
1	Supply voltage fluctuation	Voltage measured at terminal block within rated range?	Supply voltage must be within rated range.	Tester
		Momentary power failure frequently occurs? Abrupt rise in supply voltage occurs?	Supply voltage must be within rated range.	Power analyzer
2	Environments: (a) Temperature (b) Humidity (c) Vibration, shock (d) Dust (e) Corrosive gas	(a), (b) Must be within rated values  (c) Is the Controller subject to vibration or shock from surrounding machines?  (d) Does dust or foreign object collect on the Controller?  (e) Are the metallic parts discolored or corroded?	(a) $-10^{\circ}$ to $+55^{\circ}\text{C}$  (b) 35 to 85% RH.  (c) Must be in specified range.  (d) Must be free from dust and foreign objects.  (e) Must be free from discoloration and corrosion.	Thermometer, hygrometer
3	Condition of pane: (a) Is ventilation good?  (b) Is packing damaged in the sealed panel?	(a) Natural ventilation, forced ventilation, and air conditioning are adequate?  (b) Are panel packings loose or damaged?	(a) Good ventilation is essential. Temperature in panel must be $-10^{\circ}$ to $+55^{\circ}\text{C}$ .  (b) Must be free from damage.	---
4	I/O power (a) Voltage fluctuation (b) Ripple	Is voltage measured at terminal block of each I/O within rated level?	Must be within rated range.	Tester, oscilloscope
5	Mounting condition	(1) Is each device fixed securely? (2) Are connectors inserted securely? (3) Aren't screws of terminal block loose? (4) Is the wiring damaged? (5) Are the communications specifications between DC and R/W Head satisfied?	Must be tightened.  Must be locked and tightened with screws.  Must not be loose.  Must be free from damage.  Must be within rated range.	--- --- --- --- ---
6	Battery life of DC	Check the DC date of production.	Must be within guaranteed period.	---
7	Error logging	Check error.	---	---

### 5-8 Systems Check

If a malfunction has occurred, carefully investigate the surrounding conditions and check whether the trouble still persists or is related to other equipment. Then track down the malfunction according to the following procedure:

#### Main Check

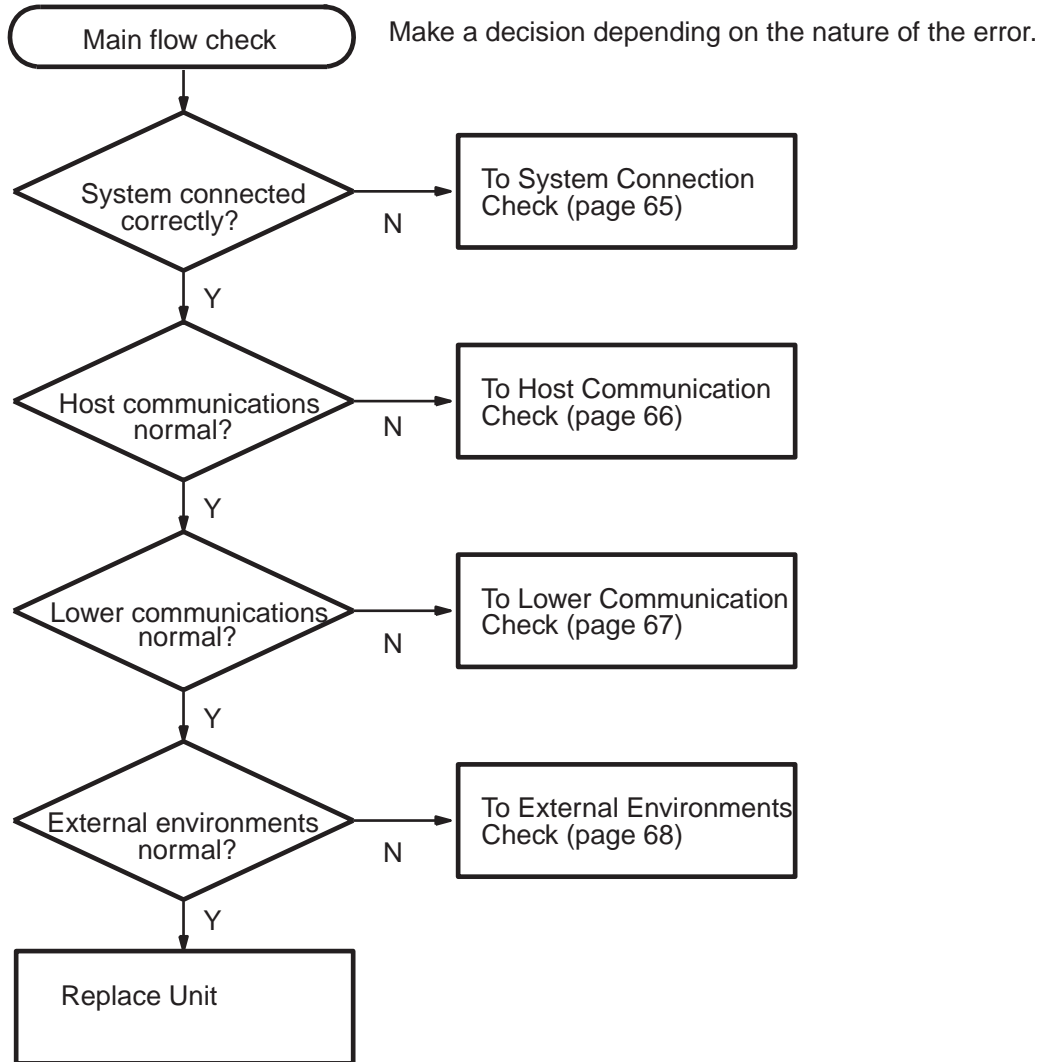

**System Connection Check**

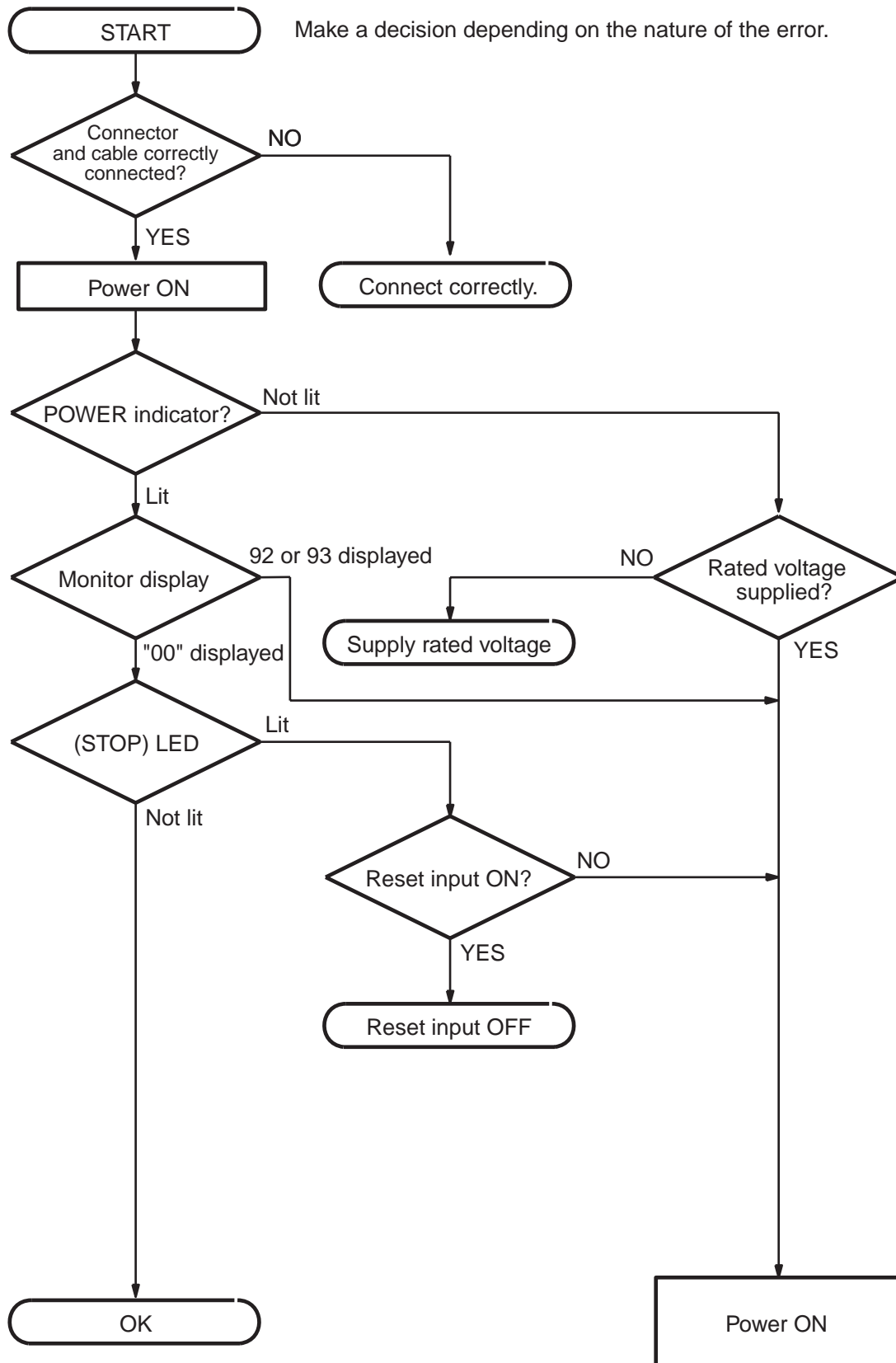

**Host Communication Check**

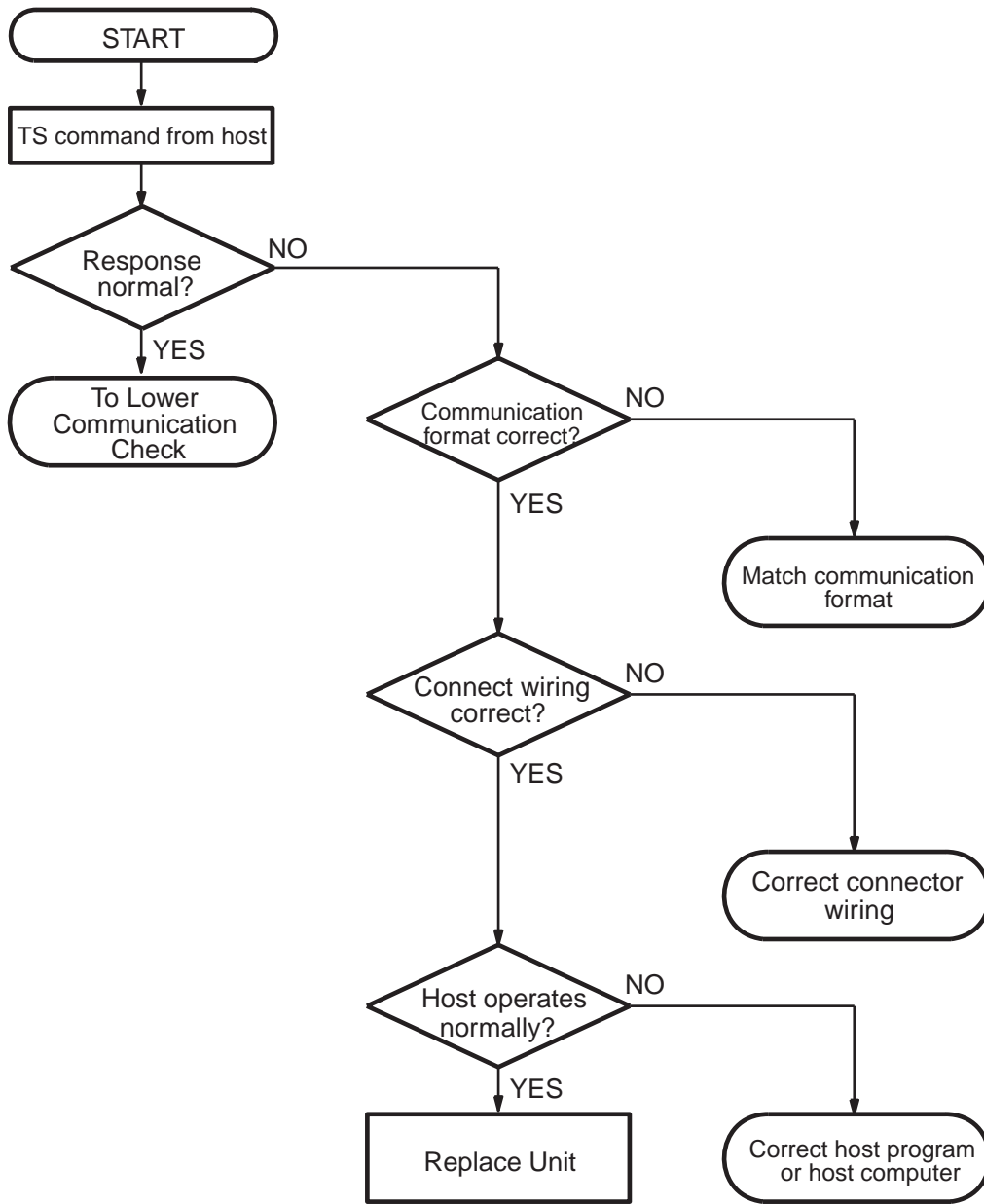

**Lower Communication Check**

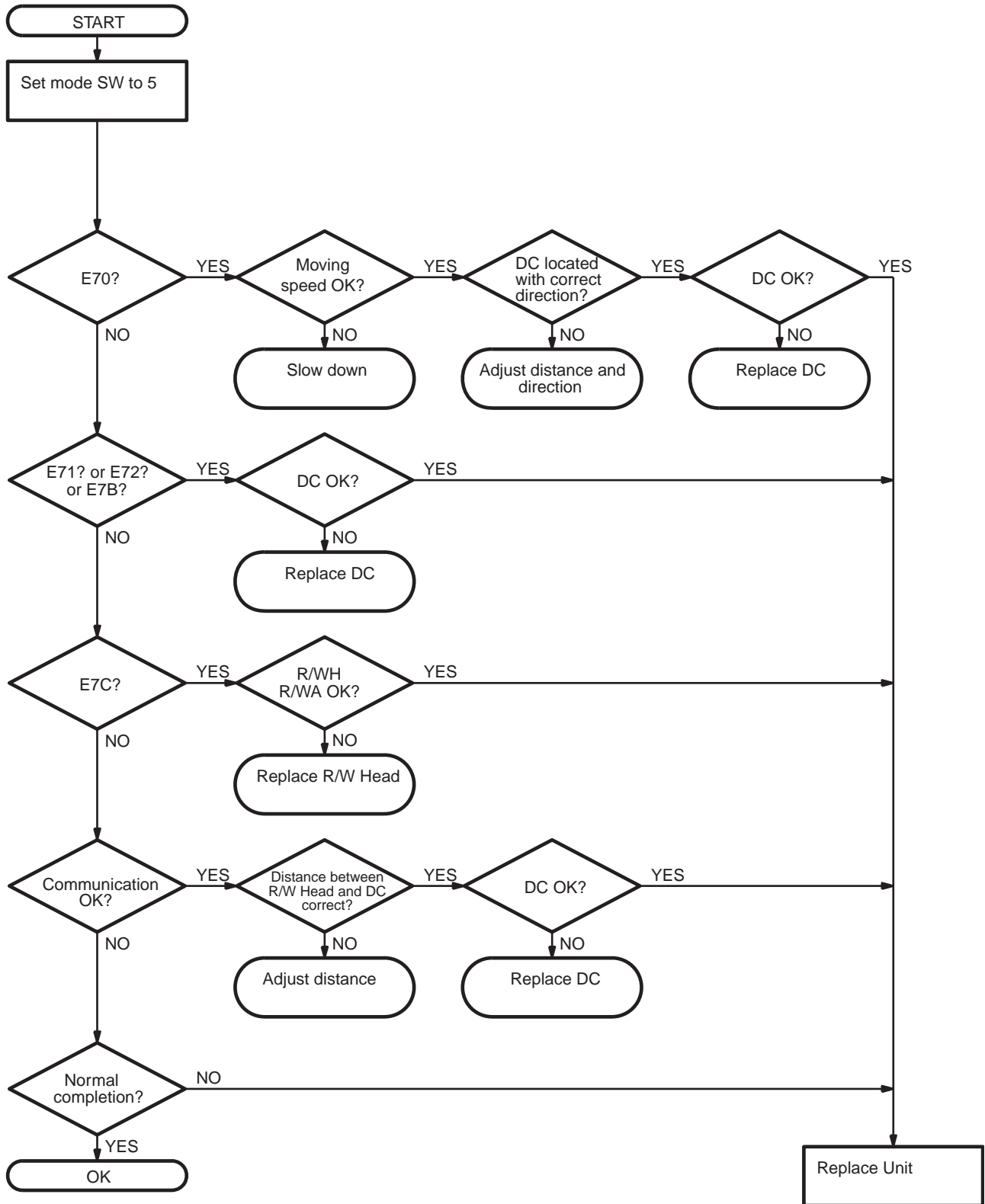

**External Environments Check**

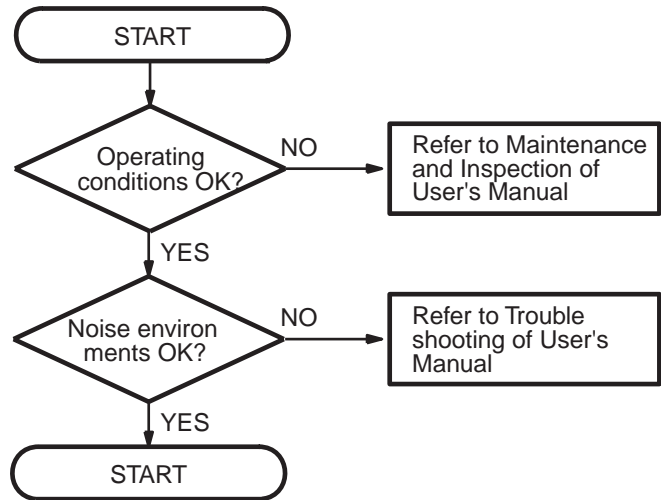

# Index

## A

- abort
  - command format, 44
- address range
  - read command, 33
  - write command, 33
- auto read, 24
  - command format, 37
  - response format, 37
- auto write, 24
  - command format, 38
  - response format, 38

## B

- battery
  - checking voltage drop, 55
  - Data Carrier battery life, 55
- bytes
  - read command, 33
  - write command, 33

## C

- checking the system
  - external environments check, 68
  - host communication check, 66
  - lower communication check, 67
  - main check, 64
  - system connection check, 65
- codes
  - warning, 54
- command
  - format, 30
  - list, 30
- command processing terminating
  - command format, 40
  - end code, 40
  - response format, 40
- command reception
  - command processing status, 22
  - command wait status, 22
  - polling auto subcommand wait status, 22
- command undefined
  - response format, 45
- communication error, 54
- communications control procedure, 22

- configuration
  - system, 3
- connector
  - R/W Head, 9
  - RS-232C interface, 9
- controller control
  - command format, 43
  - response format, 43

## D

- Data Carrier
  - command format, 56
  - EEPROM type, 56
  - memory check, 59
  - memory map, 26
  - production date, 26
  - response format, 56
  - write protect, 27
    - canceling, 29
    - setting, 27
    - setting example, 28
- data check
  - command, 40
- data code
  - ASCII, 32
  - hex code, 32
  - JIS 8 code, 32
- data management
  - command, 41
- diagnostics
  - errors, 53
  - indicators, 53
  - outputs, 53
- DIP switch setting, 16
  - mode selector switch, 16
- Display Mode
  - Error, 8
  - I/O, 8

## E

- end code list, 45
- error
  - response format, 45
- error information read
  - command format, 43
  - error log information, 44
  - response format, 43



error lists  
  host communication, 54  
  lower communication, 54  
  system error, 54  
error log information, 44  
ERROR signal output, 20  
expansion read  
  command format, 35  
  response format, 35  
expansion write  
  command format, 36  
  frame division, 36  
  response format, 36

## F

features, 2  
functions, 8

## I

I/O  
  user, 5  
indicators  
  operation, 8  
inspection  
  items, 63  
installation environment  
  location, 19

## M

maintenance, 63  
Modes  
  RUN, 16  
  TEST, 17  
monitor display, 8

## N

nomenclature, 8

## O

off-line test, 52  
operation  
  outline, 4

## P

polling, 25  
polling auto read  
  command format, 38  
  response format, 38  
  subcommand format, 39  
  subcommand response format, 39  
polling auto write  
  command format, 39  
  response format, 39  
power supply  
  external output terminals, 9  
programming example  
  host link serial system, 46

## R

read, 23  
  command format, 34  
  response format, 34  
RESET signal input, 20  
response  
  format, 30  
  list, 30  
RS-232C, 20  
RUN Mode, 16

## S

system error, 54

## T

terminals  
  external output, 9  
test  
  command format, 44  
  communications with host computer, 52  
  response format, 44  
TEST Mode, 17  
test run  
  checklist, 52  
  procedure, 52  
trigger input, 18  
troubleshooting, 62  
  influence of noise, 62

## **W**

warning codes

*See also* codes

write, 23

command format, 35

response format, 35

write command memory, 17

write processing repeat

command format, 42

response format, 42

write protect, 27

canceling, 29

setting, 27

setting example, 28

## Revision History

A manual revision code appears as a suffix to the catalog number on the front cover of the manual.

Cat. No. Z193-E1-01



The following table outlines the changes made to the manual during each revision. Page numbers refer to the previous version.

Revision code	Date	Revised content
01	December 2003	Original production