

2-Dimensional Code Reader (Fixed Type)

# V530-R160E, EP

*A code reader that handles pin-stamped markings!*



V530-R160E, EP

## Features

### Dependably Read Pin-stamped Markings

- Markings made by pin-stamping machines can be dependably read, providing the user with a wider range of selection of marking devices.
- Stable reading is possible even if the shape of cells changes because of aging in the marking device.  
(Reference: Stamping using a Vector Co. pin-stamping machine)

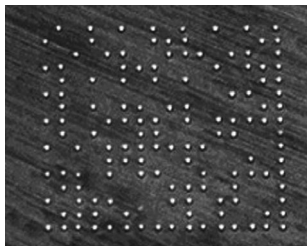

### Dot Codes\* Read at Any Angle: 360° Compatibility

- Codes can be read even with rough backgrounds on the casting surface or other locations.
- Dot codes\* can be read at any angle through a 360° range.  
\* Dot codes are 2-dimensional codes in which dots form the cells.

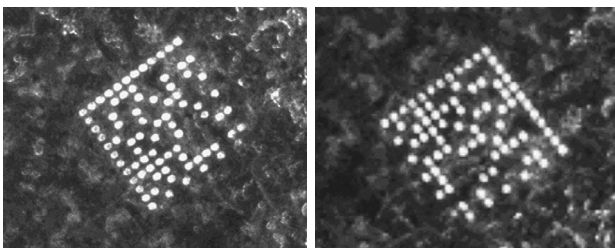

### Dependably Read Markings at an Angle

With dependable reading at an angle, installation is possible even on existing facilities with space limitations.



### Easy Setup

Setup is easily achieved with a Memory Card (compact flash memory) slot on the V530-R160E and V530-R160EP. Just insert a card to easily copy settings or save images. Carrying a personal computer and cables is no longer required for process switchovers.

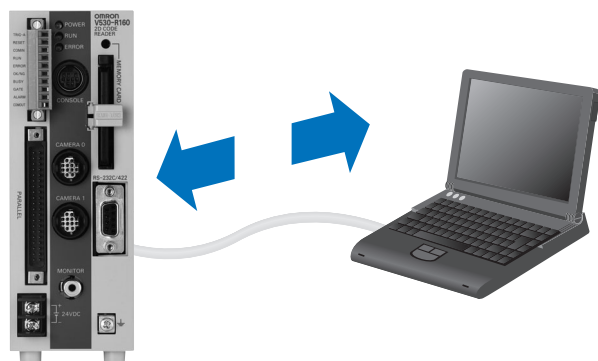

## Easy Operation and Maintenance

Trends can be monitored to achieve the following:

- Displaying changes in the status (correlation values) of codes or contrast changes on line graphs on a monitor.
- Setting alarm levels while monitoring graphs.
- Outputting external alarms if a value falls below the set value.

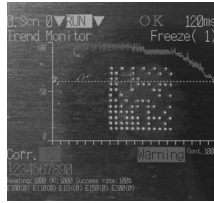

Trend monitoring can be used to set guidelines for replacing parts in lighting devices, marking devices, and other equipment.

## Easy Analysis

**Manage Data Histories**  
Histories of the number of OK and NG reads can be managed.



**Save Images to Memory Cards**  
Save approx. 200 images in 64 MB and 400 images in 128 MB.

**Check and Analyze Troubles**  
Up to 35 NG images can be saved in internal memory.



**Reproduce Images**  
Saved NG images can be loaded to reproduce a reading.

Using time stamps on NG images with data histories enables more detailed troubleshooting.

Applications

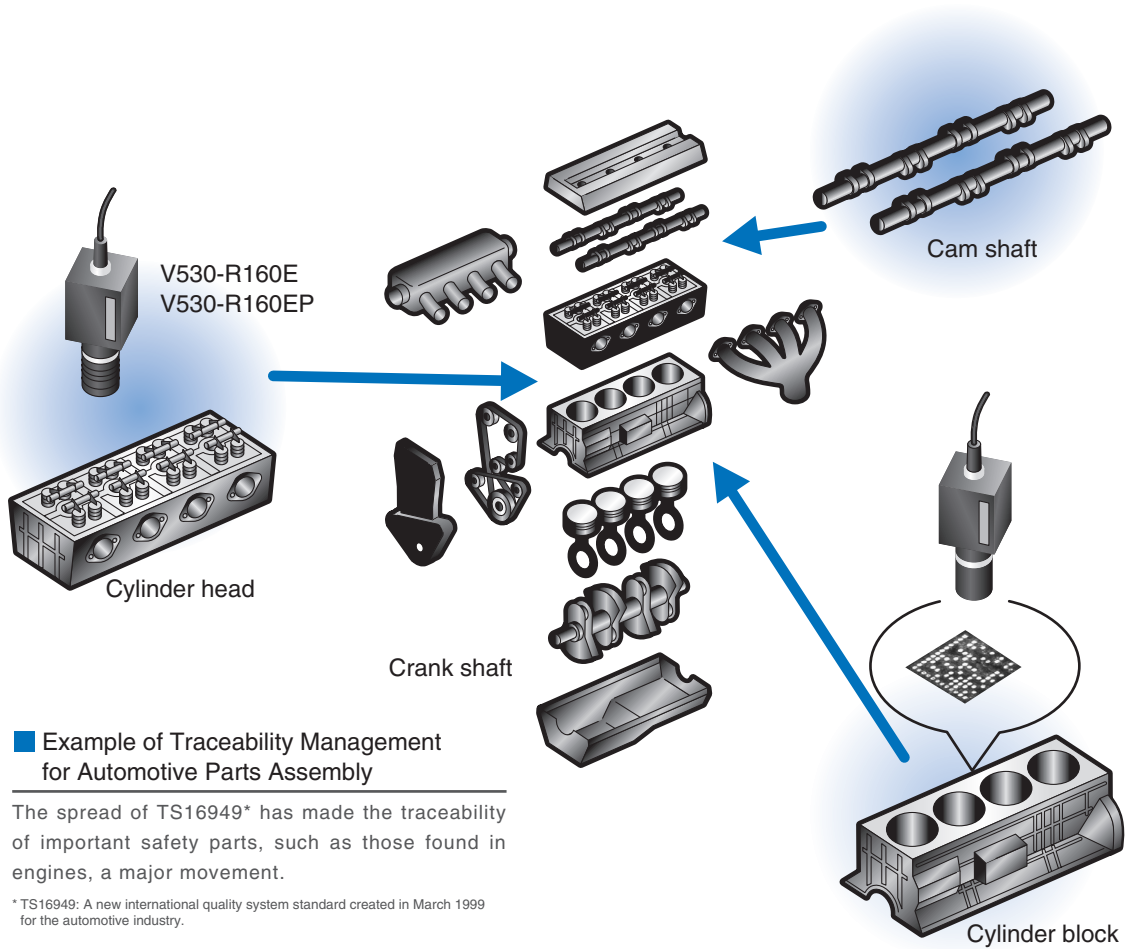

Ordering Information

List of Models

Name	Model No.	Remarks
Controller	V530-R160E, V530-R160EP	
Console	F150-KP	2-m cable
Camera	F150-S1A	
Camera Cable	F150-VS	3-m cable
Monitor Cable	F150-VM	2-m cable
Liquid Crystal Monitor	F150-M05L	
Video Monitor	F150-M09	
Parallel Cable	F160-VP	Cable with loose wires for Parallel I/O Connector (2-m cable)
Memory Card	F160-N64S(S)	Card capacity: 64 MB
RS-232C Cable	XW2Z-200S-V	For IBM PC/AT or compatible computer (2-m cable)
	XW2Z-200T	For SYSMAC PLC (2-m cable)

Specifications

V530-R160E, V530-R160EP Controller

Item	Specifications	
Model	V530-R160E	V530-R160EP
Input/Output type	NPN	PNP
Applicable codes	Data Matrix ECC200: 10 × 10 to 64 × 64, 8 × 18, 8 × 32, 12 × 26, 12 × 36, 16 × 36, 16 × 48 Data Matrix ECC000, ECC050, ECC080, ECC100, ECC140: 9 × 9 to 25 × 25 QR Code (Model 1, 2): 21 × 21 to 41 × 41 (Version 1 to 6)	
Readable direction	360°	
Number of pixels (resolution)	512 (H) × 484 (V)	
Number of connectable cameras	2 max.	
Image memory function	Maximum of 35 images stored (internal memory in Controller).	
Operation method	Selected from menu.	
Processing method	Gray	
Memory Card slot	1	
Monitor interface	1 channel (color/monochrome)	
Serial communications	RS-232C/422A, 1 channel	
Parallel I/O	5 inputs: TRIG-A, TRIG-B, TRIG-C, TRIG-D, and RESET 6 outputs: RUN, ERROR, OK/NG, BUSY, GATE, and ALARM	
Power supply voltage	20.4 to 26.4 VDC	
Current consumption	Approx. 1.6 A max.	
Ambient temperature	Operating: 0 to 50°C, storage: -25 to 65°C (with no icing or condensation)	
Ambient humidity	35% to 85% (with no condensation)	
Weight	Approx. 570 g	

F150-S1A Camera

Item	Specifications
Picture element	1/3-inch CCD
Effective pixels	659 (H) × 494 (V)
Shutter function	Electronic frame shutter Shutter speed: 1/100, 1/500, 1/2000, or 1/10000 s (menu selectable)
Ambient temperature	Operating: 0 to 50°C, storage: -25 to 60°C (with no icing or condensation)
Ambient humidity	35% to 85% (with no condensation)
Weight	Approx. 80 g

Monitor

Item	Name Model No.	Liquid Crystal Monitor F150-M05L	Video Monitor F150-M09
Size		5.5 inches	9 inches
Type		Liquid crystal color TFT	Monochrome CRT
Resolution		320 × 240 dots	800 TV lines min. (at center)
Input signal		NTSC composite video (1.0 V/75 Ω)	
Power supply voltage		20.4 to 26.4 VDC	85 to 264 VAC
Current consumption		Approx. 700 mA	Approx. 200 mA
Ambient temperature		Operating: 0 to 50°C, storage: -25 to 65°C (with no icing or condensation)	Operating: -10 to 50°C, storage: -20 to 65°C (with no icing or condensation)
Ambient humidity		Operating/Storage: 35% to 85% (with no condensation)	Operating/Storage: 10% to 90% (with no condensation)
Weight (Monitor only)		Approx. 1 kg	Approx. 4.5 kg
Accessories		Operation manual, 4 mounting brackets	Operation manual

System Configuration

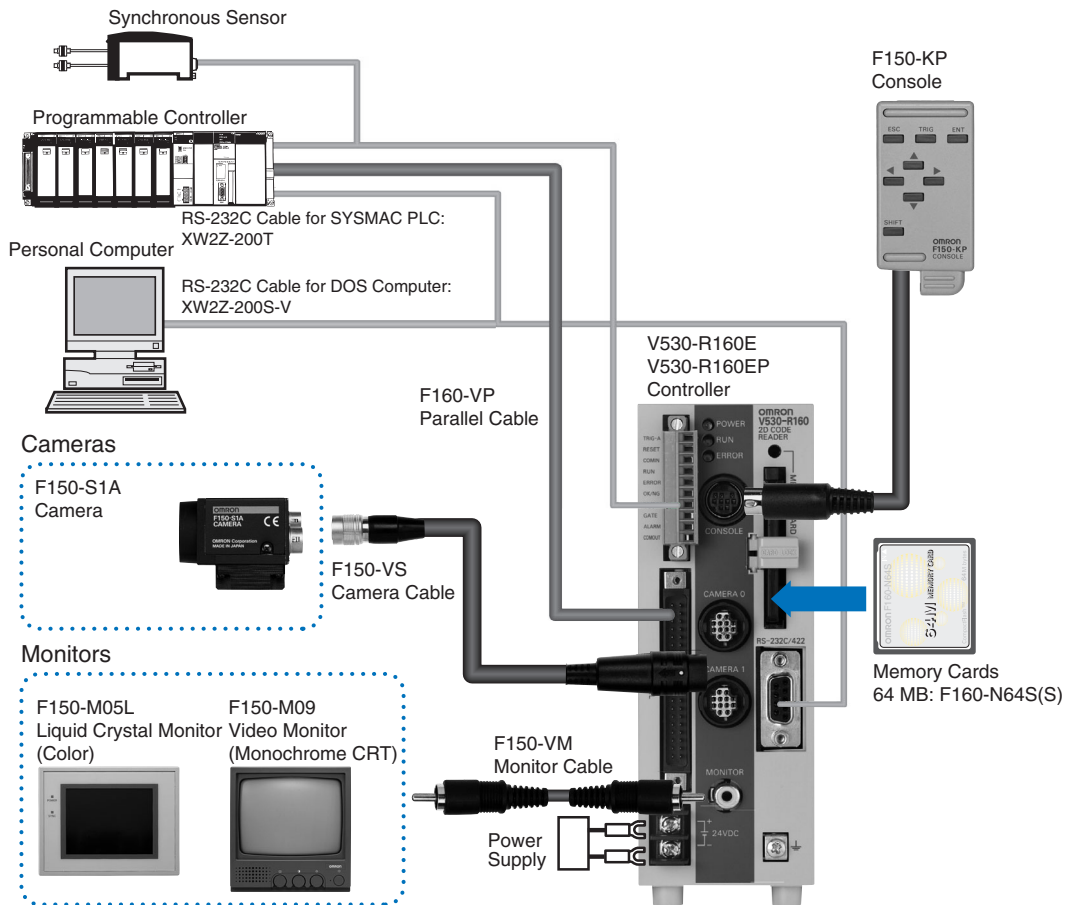

V530-R160E, EP

Dimensions

V530-R160E, V530-R160EP Controller

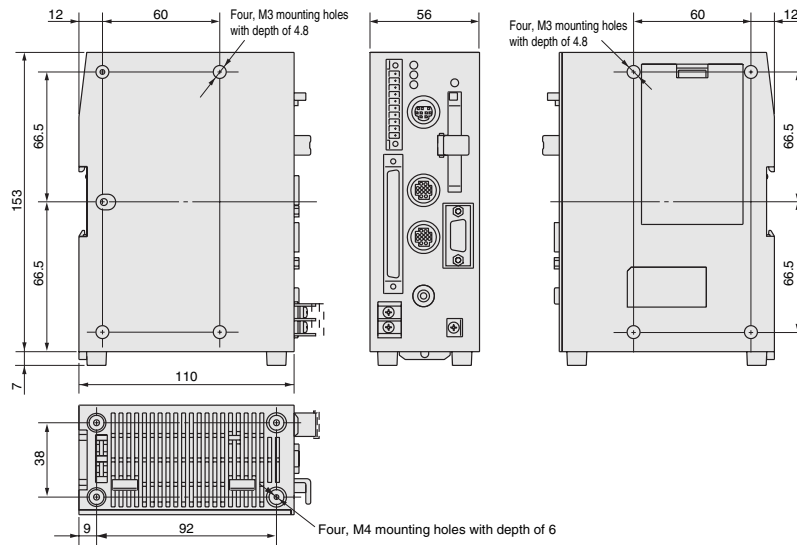

F150-S1A Camera

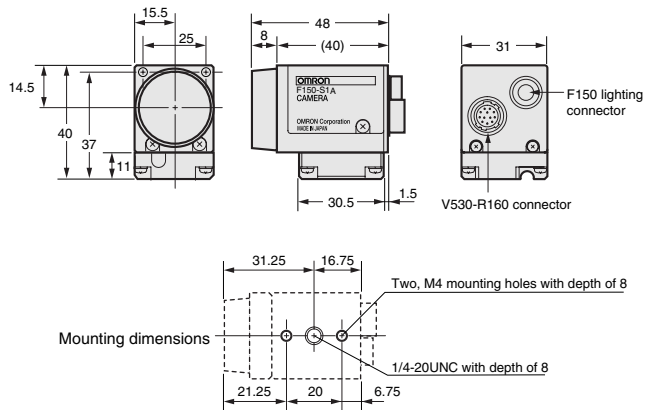

F150-KP Console

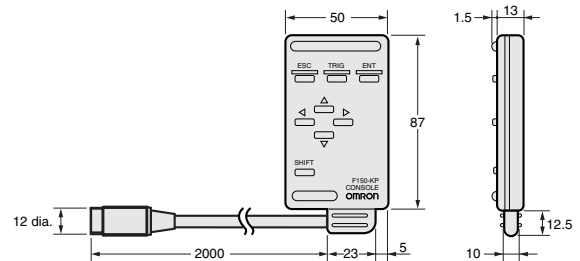

F150-M05L Liquid Crystal Monitor

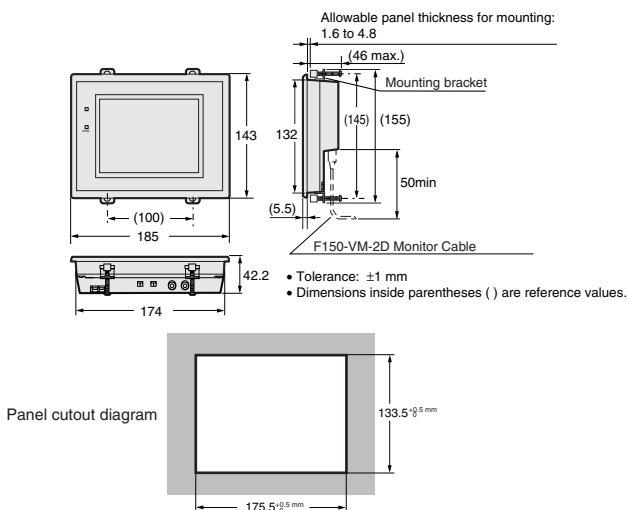

F150-M09 Video Monitor

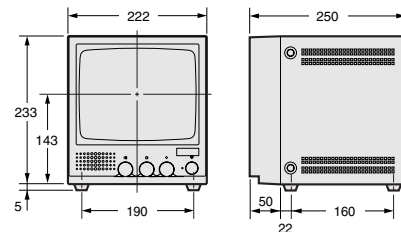

ALL DIMENSIONS SHOWN ARE IN MILLIMETERS.  
To convert millimeters into inches, multiply by 0.03937. To convert grams into ounces, multiply by 0.03527.