

# Measuring and Monitoring Relays

## K8AB Series/61F-D21T

### Industry First! Two SPDT Outputs Available in New Models DIN Sized at 22.5 mm

- Seven slim models featuring a variety of innovative new functions.  
Single-phase power monitoring: Current relay, Voltage relay, Upper-/lower-limit voltage relays.  
Three-phase power monitoring: Phase sequence relay, Voltage with phase loss relay, Voltage asymmetry relay, Voltage relay
- The K8AB-TH Temperature Monitoring Relay will join the Series in June, 2005.

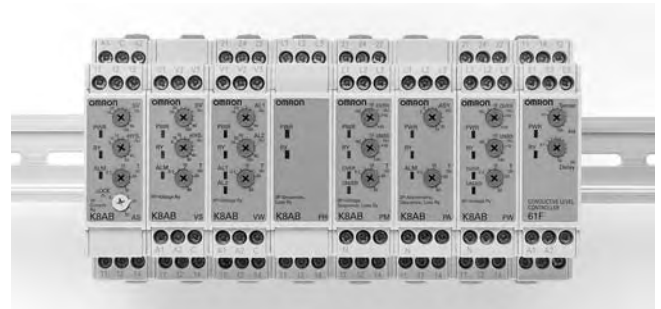

**NEW**

## Model Number Structure

### Model Number Legend

**K8AB-**        
1 2 3

#### 1. Basic Model

K8AB: Measuring and Monitoring Relays

#### 2. Functions

- AS: Single-phase Current Relay (One-sided operation)
- VS: Single-phase Voltage Relay (One-sided operation)
- VW: Single-phase Voltage Relay (Simultaneous upper and lower limit monitoring)

PH: Phase-sequence Phase-loss Relay

PM: Three-phase Phase-sequence Phase-loss Relay (Simultaneous upper and lower limit monitoring)

PA: Three-phase Asymmetry and Phase-sequence Phase-loss Relay

PW: Three-phase Voltage Relay (Simultaneous upper and lower limit monitoring)

#### 3. Rated Operating Power

## Features

### Industry First! Slim 22.5-mm Design Features Two SPDT Relay Outputs on Single- and Three-phase Power Supply Models

Many customers require the individual upper and lower limit outputs that are normally available only in larger 45-mm relays. For the first time from any manufacturer, OMRON has achieved this and more in a slim-body design measuring just 22.5 mm. These relays offer advantages such as 3-phase power supply compatibility and a relay contact capacity of 6 A at 250 VAC. What's more, they also reduce panel production cost because they use 50% less space than previous models.

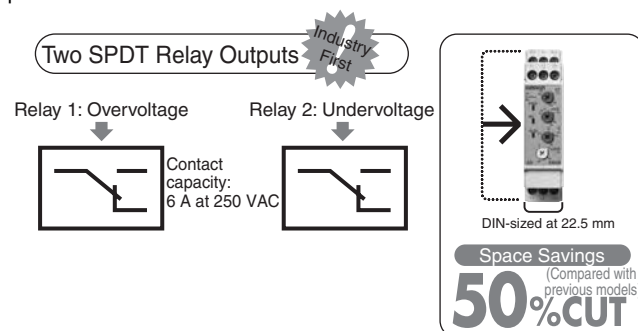

### Pre-alarm Monitoring Mode (K8AB-VW Only)

To address this problem, the K8AB-VW features a pre-alarm monitoring mode with settings for pre-alarm outputs (H/HH alarms and L/LL alarms) separate from the trip outputs. The K8AB-VW makes scheduled maintenance viable because the pre-alarm monitoring mode provides advance warning of impending trip alarms.

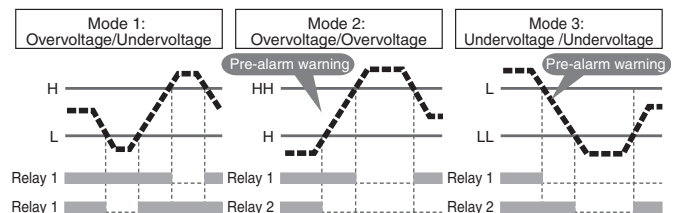

## Wide Setting Ranges

These new Relays offer full-span overvoltage and undervoltage range settings for unprecedented voltage monitoring flexibility.

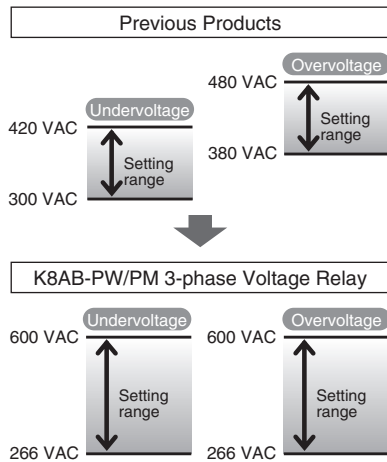

## DIP Switch Function Selection

Various relay functions can be selected using a DIP switch. This means that the number of models required can be reduced to 1/8 what it has been simply by installing a relay like the K8AB-AS. An added advantage is that it reduces the inventory of maintenance parts

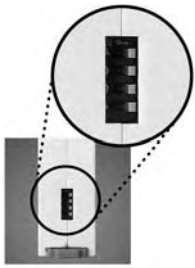

Example: K8AB-AS Single-phase Current Relay

	DIP switch		Function
	SW2	SW3	
<b>Reset mode</b>	OFF	OFF	Manual reset
	ON	OFF	Automatic reset
<b>Relay operation mode</b>	OFF	OFF	Normally open
	ON	OFF	Normally closed
<b>Monitoring mode</b>	OFF	OFF	Overcurrent
	ON	OFF	Undercurrent

- Note:**
1. A single K8AB-AS can be used for both instantaneous and time delay operation.
  2. SW1 is not used.

## A Single K8AB Monitors 3-phase Power Supplies with 3 or 4 Wires

K8AB-PM, PA, and PW can be used to monitor 3-phase power supplies with 3 or 4 wires simply by changing DIP switch settings.

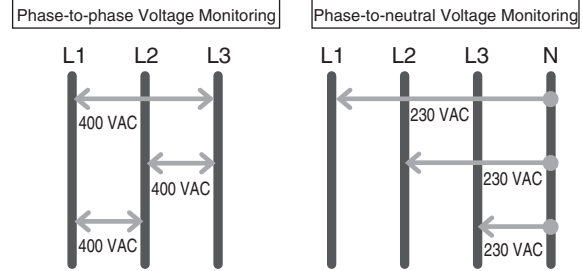

## A Single K8AB Can Monitor a 3-phase Power Supply Anywhere In The World

Reduces Maintenance Parts Inventory

	SW3			ON	ON	OFF	OFF
	SW4			ON	OFF	ON	OFF
K8AB-PW1 (240 V)	SW2	ON	P-P	200 V	200 V	230 V	240 V
		OFF	P-N	115 V	127 V	133 V	138 V
K8AB-PW2 (480 V)	SW2	ON	P-P	380 V	400 V	415 V	480 V
		OFF	P-N	220 V	230 V	240 V	277 V

## Operation Level Indication by Flashing Alarm Indicator

Checking the operating status has never been convenient because of the time it takes to reach the preset operating time. The K8AB eliminates this problem by featuring a flashing alarm indicator that clearly indicates the operating status. This has greatly simplified the task of checking on-site status particularly when operation settings are changed or an error occurs.

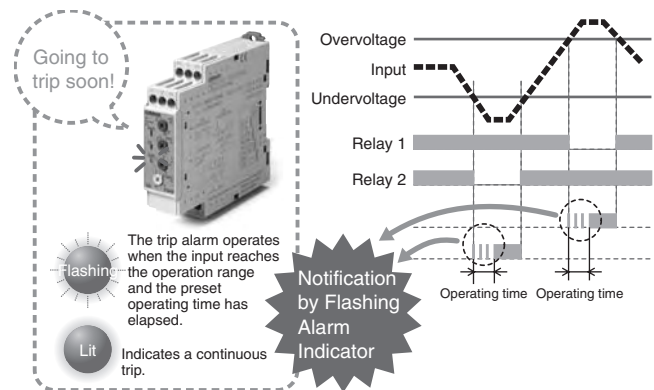

## Ideal for Monitoring Current or Voltage

### Current Monitoring Applications (Single Phase)

Application	Measured current	Applicable model	Setting range of operating value
Monitoring instrumentation signals of simple sensor controllers	4 to 20 mA DC	K8AB-AS1	2 to 20 mA AC/DC
			10 to 100 mA AC/DC
			50 to 500 mA AC/DC
Monitoring motor or heater current (Using a commercial CT)	0 to 1 A AC 0 to 5 A AC	K8AB-AS2	0.1 to 1 A AC/DC
			0.5 to 5 A AC/DC
			0.8 to 8 A AC/DC
Monitoring motor or heater current (Using a dedicated CT)	0 to 200 A AC	K8AC-AS3 (See note.)	---
			10 to 100 A AC
			20 to 200 A AC

**Note:** The model number of the dedicated CT is K8AC-CT200L (OMRON)

### Voltage Monitoring Applications (Single Phase)

Application	Measured current	Applicable model	Setting range of operating value
Monitoring direct current (monitoring the output voltage of a shunt)	0 to 60 mV DC 0 to 100 mV DC 0 to 150 mV DC	K8AB-VS1 K8AB-VW1	6 to 60 mV AC/DC
			10 to 100 mV AC/DC
			30 to 300 mV AC/DC
Monitoring a power supply line	12 VDC	K8AB-VS2	1 to 10 V AC/DC
	24 VDC	K8AB-VW2	3 to 30 V AC/DC
	100 VAC		15 to 150 V AC/DC
	115 VAC	K8AC-VS3 K8AB-VW3	20 to 200 V AC/DC
	200 VAC		30 to 300 V AC/DC
	230 VAC		60 to 600 V AC/DC
400 VAC			
480 VAC			

### Easy Wiring with Ferrules

2 × 2.5 mm<sup>2</sup> solid or 2 × 1.5 mm<sup>2</sup> standard ferruled.

### A third party has certified CE mark compliance.

Approval for UL certification is pending.



# Selection Guide

Item		Model	K8AB-AS	K8AB-VS	K8AB-VW	K8AB-PH	K8AB-PM	K8AB-PA	K8AB-PW	
Functions	Single-phase power supply	Overcurrent/undercurrent (switchable)	Yes							
		Overvoltage/undervoltage (switchable)		Yes						
		Overvoltage/undervoltage (window comparator)			Yes					
	3-phase power supply	3-phase 3-wire	Phase sequence				Yes	Yes	Yes	
			Phase loss				Yes	Yes	Yes	
		3-phase 3-/4-wire (Switchable) power	Phase sequence					Yes	Yes	
			Phase loss					Yes	Yes	
	Asymmetry						Yes			
	Overvoltage/undervoltage (window comparator)					Yes		Yes		
Output relays		One SPDT relay	Yes	Yes		Yes		Yes		
		Two SPDT relays			Yes		Yes		Yes	
Operation		Operation level setting	Yes	Yes	Yes		Yes	Yes	Yes	
		Operating time setting	Yes	Yes	Yes		Yes	Yes	Yes	
		Individual upper/lower limit settings (individual outputs)			Yes		Yes		Yes	
		Function selection (DIP switch)	Yes	Yes	Yes		Yes	Yes	Yes	
		Pre-alarm warning mode			Yes					
Indications		Power indicator/Operating status indicator	Yes	Yes	Yes	Yes	Yes	Yes	Yes	
		Trip warning indicator (flashing alarm indicator)	Yes	Yes	Yes		Yes	Yes	Yes	
Safety standards		CE (See note 1.)	Yes	Yes	Yes	Yes	Yes	Yes	Yes	
		UL	(See note 2.)	(See note 2.)	(See note 2.)	(See note 2.)	(See note 2.)	(See note 2.)	(See note 2.)	

Note: 1. CE mark compliance certified by third party.

2. UL certification pending.

# Applications

### Chain Breakage Protection for Conveyors K8AB-AS

**Purpose**  
When the motor locks, its rotational torque may break the chain. To prevent that from happening, the relay must trip the instant it detects a motor lock error. A thermal relay cannot be used for chain protection because it takes too long to start operating.

**Advantages**  
The K8AB-AS offers effective chain protection because it starts operating in 0.1 s or less.

### Battery Voltage Checking K8AB-VS

**Purpose**  
The K8AB-VS is used to check battery charge levels.

**Advantages**  
The K8AB-AS can detect when the battery charge is low.

### Protection against Idle Running of a Submersible Pump K8AB-AS

**Purpose**  
A submersible pump must be turned OFF as soon as it begins to operate out of water, or it will immediately malfunction. Instantaneous detection of this kind of idle operation is essential.

**Advantages**  
The K8AB-AS can detect idle pump operation by detecting undercurrent levels.

### Monitoring the Control Power Supply at Communications Bases K8AB-VW

**Purpose**  
Communications bases must be carefully monitored because the effects of a power outage or voltage drop would be highly detrimental to communications. The K8AB-VW monitors the control power supply for overvoltage and undervoltage levels.

**Advantages**  
Overvoltage and undervoltage can be detected with a single K8AB-VW. It can also output individual overvoltage and undervoltage alarms using SPDT relays, and can provide a pre-alarm warning output to eliminate system downtime.

### Bulb Burnout Detection K8AB-AS

**Purpose**  
The K8AB-AS is used to detect burned out light bulbs.

**Advantages**  
The K8AB-AS can detect burned out light bulbs by detecting undercurrent levels. The Relay's sensitivity can be adjusted to detect burned out light bulbs even in applications where multiple light bulbs are used.

### Monitoring Phase Sequence or Phase Loss for Escalators K8AB-PH

**Purpose**  
The K8AB-PH detects phase-sequence or phase-loss errors in escalator power supplies.

**Advantages**  
A single K8AB-PH can detect the phase sequence or phase loss at startup and during operation.

### Monitoring Generated Voltage K8AB-PW

**Purpose**  
The K8AB-PW monitors the voltage of power generated by a generator. It also detects overvoltage and undervoltage in power from a generator.

**Advantages**  
A single K8AB-PW can monitor three-phase voltage. It can also output individual alarms for overvoltage and undervoltage using SPDT relays because it features two outputs with SPDT relays. The voltage measurement range can be switched from 200 to 480 VAC, and the K8AB-PW can be switched to monitor phase voltage or line voltage.

### Monitoring Compressor Power Supplies K8AB-PM

**Purpose**  
Compressors cannot operate correctly when there is a voltage drop or voltage unbalance, or a phase-sequence or phase-loss error. The K8AB-PM can be used to monitor three-phase voltage, phase-sequence, and phase-loss errors.

**Advantages**  
A single K8AB-PM can monitor overvoltage or undervoltage, as well as phase-sequence, and phase-loss errors in three-phase voltage. It can also output individual alarms for overvoltage or undervoltage using SPDT relays. This makes it possible to determine which type of error occurred.

### Monitoring Voltage Generated by Wind-Powered Generators K8AB-PW

**Purpose**  
The K8AB-PW detects overvoltage and undervoltage in power generated by a wind-powered generator.

**Advantages**  
A single K8AB-PW can be used for a three-phase power supply with three or four wires. It can be used to individually set and output overvoltage and undervoltage alarms.

### Controlling the Liquid Level in a Tank 61F-D21T-V1

**Purpose**  
The 61F-D21T-V1 can be used to control the liquid level in a tank.

**Advantages**  
Because the sensitivity resistance can be adjusted from 10 to 100 kW, there is no need to change models to match different liquid types and concentrations. You can also set the operation time in a range of 0.1 to 10 seconds to prevent operating errors due to chattering. Water supply and draining control can be changed by DIP switch.

# Single-phase Current Relay K8AB-AS

**Ideal for current monitoring for industrial heaters and motors.**

- Monitor for overcurrents or undercurrents.
- Manual resetting and automatically resetting supported by one Relay.
- Startup lock and operating time can be set separately.
- One SPDT output relay, 6 A at 250 VAC (resistive load).
- Switch the output relay between normally ON and normally OFF operation.
- Process control signal (4 to 20 mA) and commercial CT input (0 to 1 A or 0 to 5 A) supported.
- Relay warning status easily monitoring using LED indicator.



**NEW**

## Ordering Information

### ■ List of Models

Model	Rated operating power	Rated input (See note 1.)	
K8AB-AS1	24 VDC 24 VAC 100 to 115 VAC 200 to 230 VAC	I1-COM	2 to 20 mA AC/DC
		I2-COM	10 to 100 mA AC/DC
		I3-COM	50 to 500 mA AC/DC
K8AB-AS2	24 VDC 24 VAC 100 to 115 VAC 200 to 230 VAC	I1-COM	0.1 to 1 A AC/DC
		I2-COM	0.5 to 5 A AC/DC
		I3-COM	0.8 to 8 A AC/DC
K8AB-AS3	24 VDC 24 VAC 100 to 115 VAC 200 to 230 VAC	I1-COM	---
		I2-COM	10 to 100 A AC (See note 2.)
		I3-COM	20 to 200 A AC (See note 2.)

**Note: 1.** The rated input depends on the connected terminals. Select the terminals suitable for the inputs, and connect the inputs to I1-COM, I2-COM, and I3-COM.

**2.** The K8AB-AS3 is specially designed to be used in combination with the OMRON K8AC-CT200L Current Transformer (CT). (Direct input is not possible.)

### ■ OMRON CT

Model	Input range	Applicable Relay
K8AC-CT200L	10 to 100 A AC 20 to 200 A AC	K8AB-AS3

### ■ Commercial CTs

CT current on secondary side	Applicable Relay	Input terminals
0 to 1 A AC	K8AB-AS2	I1-COM
0 to 5 A AC		I2-COM

# Ratings and Specifications

## ■ Ratings

Operating power	Non-isolated power supply	24 VDC (1 W)
	Isolated power supply	24 VAC (3 VA), 100 to 115 VAC (4 VA), 200 to 230 VAC (5 VA)
Operate (SV)	Operating value setting range	10% to 100% of maximum rated input value
	Operating value	100% operation at set value
Reset (HYS.)	Hysteresis	5% to 50% of operating value
	Resetting method	Manual reset/automatic reset (switchable) Manual reset: Turn OFF operating power for 1 s or longer.
Operating time (T)		0.1 to 30 s (Value when input rapidly changes from 0% to 120%.)
Operating power ON lock (LOCK)		0 to 30 s (Value when input rapidly changes from 0% to 120%; lock timer starts when input reaches approximately 30% of set value.)
Repeat accuracy		±10% (rdg) of operating value
Time error		±10% of set value (Minimum error: 50 ms)
Input frequency	K8AB-AS1/AS2	DC input, 45 to 65 Hz
	K8AB-AS3	45 to 65 Hz
Continuous input	K8AB-AS1/AS2	Continuous input: 115% of maximum input, 10 s max.: 125% of maximum input
	K8AB-AS3	Continuous input: 240 A, 30 s max.: 400 A, 1 s max.: 1,200 A
Input impedance		5 Ω max.
Indicators		Power (PWR): Green LED, Relay output (RY): Yellow LED, Alarm outputs (ALM): Red LED
Output relays		One SPDT relay (6 A at 250 VAC, resistive load)

## ■ Specifications

Ambient operating temperature		-20 to 60°C (with no condensation or icing)
Storage temperature		-40 to 70°C (with no condensation or icing)
Ambient operating humidity		25% to 85%
Storage humidity		25% to 85%
Altitude		2,000 m max.
Operating voltage range		85% to 110% of rated operating voltage
Rated power supply frequency		50/60 Hz ±5 Hz (AC power supply)
Output relays	Resistive load	6 A at 250 VAC ( $\cos \phi = 1$ ) 6 A at 30 VDC (L/R = 0 ms)
	Inductive load	1 A at 250 VAC ( $\cos \phi = 0.4$ ) 1 A at 30 VDC (L/R = 7 ms)
	Minimum load	10 mA at 5 VDC
	Maximum contact voltage	250 VAC
	Maximum contact current	6 A AC
	Maximum switching capacity	1,500 VA
	Mechanical life	10,000,000 operations
	Electrical life	Make: 50,000 times, Break: 30,000 times
Standards	Approved standards	EN60255-5 and EN60255-6
	Application standards	EN61326 and EN60664-1 (pollution level 2, overvoltage category III)
Terminal screw tightening torque		1.2 N·m
Crimp terminals		Two solid wires of 2.5 mm <sup>2</sup> , two crimp terminals of 1.5 mm <sup>2</sup> with insulation sleeves, can be tightened together
Insulation resistance		20 MΩ (at 500 V) between charged terminals and exposed uncharged parts 20 MΩ (at 500 V) between any charged terminals (i.e., between input, output, and power supply terminals)
Degree of protection		Terminal section: IP20, Rear case: IP40
Case color		Munsell 5Y8/1 (ivory)
Case material		ABS resin (self-extinguishing resin) UL94-V0
Weight		200 g
Mounting		Mounted to DIN Track or via M4 screws
Dimensions		22.5 (W) x 90 (H) x 100 (D) mm



# Connections

## ■ Wiring Diagram

### Overcurrent Operation Diagram (Output: Normally Open)

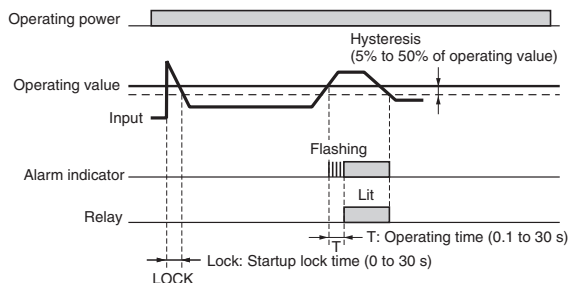

### Undercurrent Operation Diagram (Output: Normally Closed)

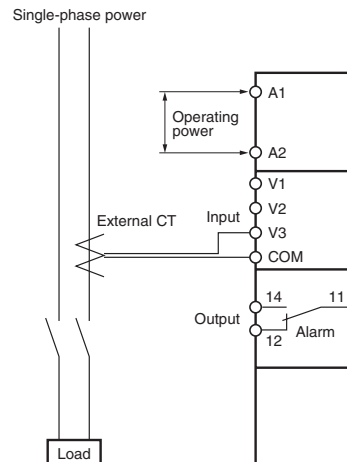
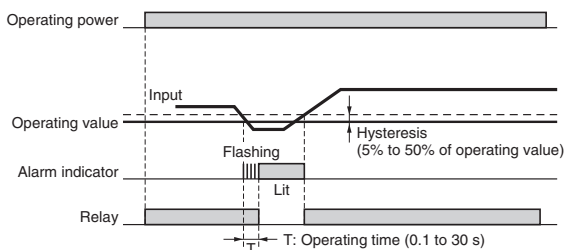

# Nomenclature

## ■ Front

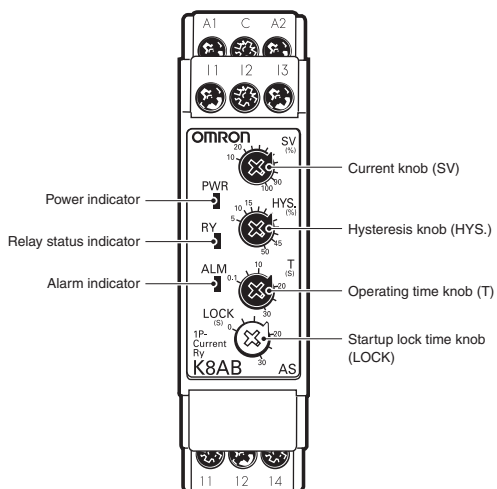

## Indicators

Item	Meaning
Power indicator (PWR: Green)	Lit when power is being supplied.
Relay status indicator (RY: Yellow)	Lit when relay is operating.
Alarm indicator (ALM: Red)	Lit when there is an overcurrent or undercurrent. The indicator flashes to indicate the error status after the input has exceeded the threshold value while the operating time is being clocked.

## Setting Knobs

Item	Usage
Current knob (SV)	Used to set the current to 10% to 100% of maximum rated input current.
Hysteresis knob (HYS.)	Used to set the rest value to 5% to 50% of the operating value.
Operating time knob (T)	Used to set the operating time to 0.1 to 30 s.
Startup lock time knob (LOCK)	Used to set the startup lock time to 0 to 30 s.

## ■ Function Selection DIP Switch

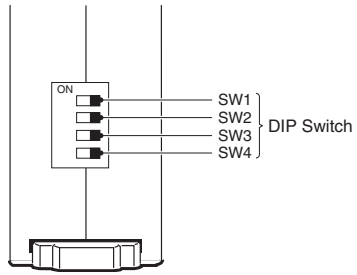

## DIP Switch Functions

		Function		Default
<b>SW1</b>	Not used.	OFF	Not used.	OFF
		ON		
<b>SW2</b>	Resetting method	OFF	Manual reset	OFF
		ON	Automatic reset	
<b>SW3</b>	Relay drive method	OFF	Normally open (normally OFF)	OFF
		ON	Normally closed (normally ON)	
<b>SW4</b>	Operating mode	OFF	Overcurrent monitoring	OFF
		ON	Undercurrent monitoring	

# Single-phase Voltage Relay K8AB-VS

**Ideal for voltage monitoring for industrial facilities and equipment.**

- Monitor for overvoltages or undervoltages.
- Manual resetting and automatically resetting supported by one Relay.
- One SPDT output relay, 6 A at 250 VAC (resistive load).
- Switch the output relay between normally ON and normally OFF operation.
- Process control signal (0 to 10 V) and current splitter input supported.
- Relay warning status easily monitoring using LED indicator.
- Input frequency of 40 to 500 Hz supported.



**NEW**

## Ordering Information

### ■ List of Models

Model	Rated operating power	Rated input (See note.)	
K8AB-VS1	24 VDC 24 VAC 100 to 115 VAC 200 to 230 VAC	V1-COM	6 to 60 mV AC/DC
		V2-COM	10 to 100 mV AC/DC
		V3-COM	30 to 300 mV AC/DC
K8AB-VS2	24 VDC 24 VAC 100 to 115 VAC 200 to 230 VAC	V1-COM	1 to 10 V AC/DC
		V2-COM	3 to 30 V AC/DC
		V3-COM	15 to 150 V AC/DC
K8AB-VS3	24 VDC 24 VAC 100 to 115 VAC 200 to 230 VAC	V1-COM	20 to 200 V AC/DC
		V2-COM	30 to 300 V AC/DC
		V3-COM	60 to 600 V AC/DC

**Note:** The rated input depends on the connected terminals. Select the terminals suitable for the inputs, and connect the inputs to V1-COM, V2-COM, and V3-COM.

# Ratings and Specifications

## ■ Ratings

Operating power	Non-isolated power supply	24 VDC (1 W)
	Isolated power supply	24 VAC (4 VA), 100 to 115 VAC (4 VA), 200 to 230 VAC (5 VA)
Operate (SV)	Operating value setting range	10% to 100% of maximum rated input value
	Operating value	100% operation at set value
Reset (HYS.)	Hysteresis	5% to 50% of operating value
	Resetting method	Manual reset/automatic reset (switchable) Manual reset: Turn OFF operating power for 1 s or longer.
Operating time (T)	0.1 to 30 s (Value when input rapidly changes from 0% to 120%.)	
Power ON lock (LOCK)	1 s or 5 s error $\pm 0.5$ s (Value when input rapidly changes from 0% to 100%. The operating time is the shortest at this point.)	
Repeat accuracy	$\pm 10\%$ (rdg) of operating value	
Time error	$\pm 10\%$ of set value (Minimum error: 50 ms)	
Input frequency	40 to 500 Hz	
Input impedance	K8AB-VS1: 9 k $\Omega$ min. K8AB-VS2: 100 k $\Omega$ min. K8AB-VS3: 1 M $\Omega$ min.	
Indicators	LED Power (PWR): Green LED, Relay output (RY): Yellow LED, Alarm output (ALM): Red LED	
Output relays	One SPDT relay (6 A at 250 VAC, resistive load)	

## ■ Specifications

Ambient operating temperature	-20 to 60°C (with no condensation or icing)	
Storage temperature	-40 to 70°C (with no condensation or icing)	
Ambient operating humidity	25% to 85%	
Storage humidity	25% to 85%	
Altitude	2,000 m max.	
Operating voltage range	85% to 110% of rated operating voltage	
Rated power supply frequency	50/60 Hz $\pm 5$ Hz (AC power supply)	
Output relays	Resistive load	6 A at 250 VAC ( $\cos \phi = 1$ ) 6 A at 30 VDC (L/R = 0 ms)
	Inductive load	1 A at 250 VAC ( $\cos \phi = 0.4$ ) 1 A at 30 VDC (L/R = 7 ms)
	Minimum load	10 mA at 5 VDC
	Maximum contact voltage	250 VAC
	Maximum contact current	6 A AC
	Maximum switching capacity	1,500 VA
	Mechanical life	10,000,000 operations
	Electrical life	Make: 50,000 times, Break: 30,000 times
Standards	Approved standards	EN60255-5 and EN60255-6
	Application standards	EN61326 and EN60664-1 (pollution level 2, overvoltage category III)
Terminal screw tightening torque	1.2 N·m	
Crimp terminals	Two solid wires of 2.5 mm <sup>2</sup> , two crimp terminals of 1.5 mm <sup>2</sup> with insulation sleeves, can be tightened together	
Insulation resistance	20 M $\Omega$ (at 500 V) between charged terminals and exposed uncharged parts 20 M $\Omega$ (at 500 V) between any charged terminals (i.e., between input, output, and power supply terminals)	
Degree of protection	Terminal section: IP20, Rear case: IP40	
Case color	Munsell 5Y8/1 (ivory)	
Case material	ABS resin (self-extinguishing resin) UL94-V0	
Weight	200 g	
Mounting	Mounted to DIN Track or via M4 screws	
Dimensions	22.5 (W) x 90 (H) x 100 (D) mm	

# Connections

## ■ Wiring Diagram

### Overcurrent Operation Diagram (Output: Normally Closed)

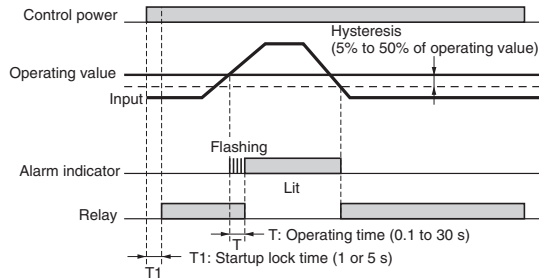

**Note:** The power ON lock prevents unnecessary alarms from being generated during the instable period when the power is first turned on. There is no relay output during timer operation.

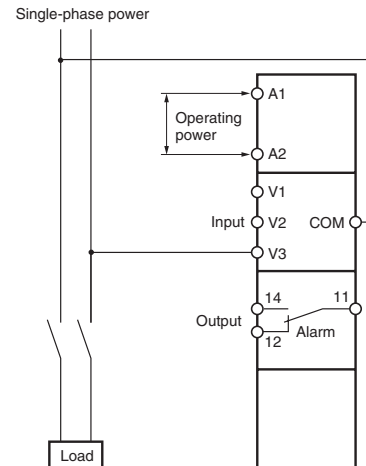

### Undercurrent Operation Diagram (Output: Normally Open)

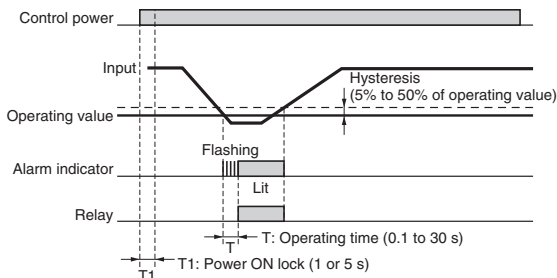

**Note:** The power ON lock prevents unnecessary alarms from being generated during the instable period when the power is first turned on. There is no relay output during timer operation.

## Nomenclature

### ■ Front

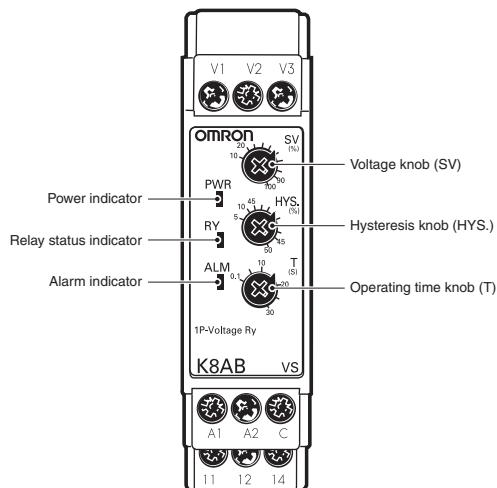

### Indicators

Item	Meaning
Power indicator (PWR: Green)	Lit when power is being supplied.
Relay status indicator (RY: Yellow)	Lit when relay is operating.
Alarm indicator (ALM: Red)	Lit when there is an overvoltage or undervoltage. The indicator flashes to indicate the error status after the input has exceeded the threshold value while the operating time is being clocked.

### Setting Knobs

Item	Usage
Current knob (SV)	Used to set the current to 10% to 100% of maximum rated input current.
Hysteresis knob (HYS.)	Used to set the rest value to 5% to 50% of the operating value.
Operating time knob (T)	Used to set the operating time to 0.1 to 30 s.

## ■ Function Selection DIP Switch

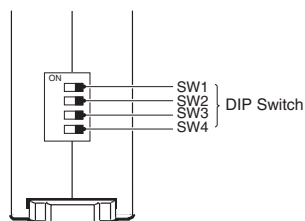

## DIP Switch Functions

		Function		Default
SW1	Power ON lock time	OFF	1 s	OFF
		ON	5 s	
SW2	Resetting method	OFF	Manual reset	OFF
		ON	Automatic reset	
SW3	Relay drive method	OFF	Normally open (normally OFF)	OFF
		ON	Normally closed (normally ON)	
SW4	Operating mode	OFF	Overvoltage monitoring	OFF
		ON	Undervoltage monitoring	

# Single-phase Voltage Relay K8AB-VW

**Ideal for voltage monitoring for industrial facilities and equipment.**

- Monitor for overvoltages and undervoltages simultaneously. Separate settings and outputs supported for overvoltages and undervoltages.
- Manual resetting and automatically resetting supported by one Relay.
- Pre-alarm Mode (H/HH and L/LL operating modes)
- Two SPDT output relays, 6 A at 250 VAC (resistive load).
- Process control signal (0 to 10 V) and current splitter input supported.
- Relay warning status easily monitoring using LED indicator.
- Input frequency of 40 to 500 Hz supported.



**NEW**

## Ordering Information

### ■ List of Models

Model	Rated operating power	Rated input (See note.)	
		Terminal	Rated Input
K8AB-VW1	24 VDC 24 VAC 100 to 115 VAC 200 to 230 VAC	V1-COM	6 to 60 mV AC/DC
		V2-COM	10 to 100 mV AC/DC
		V3-COM	30 to 300 mV AC/DC
K8AB-VW2	24 VDC 24 VAC 100 to 115 VAC 200 to 230 VAC	V1-COM	1 to 10 V AC/DC
		V2-COM	3 to 30 V AC/DC
		V3-COM	15 to 150 V AC/DC
K8AB-VW3	24 VDC 24 VAC 100 to 115 VAC 200 to 230 VAC	V1-COM	20 to 200 V AC/DC
		V2-COM	30 to 300 V AC/DC
		V3-COM	60 to 600 V AC/DC

**Note:** The rated input depends on the connected terminals. Select the terminals suitable for the inputs, and connect the inputs to V1-COM, V2-COM, and V3-COM.

# Ratings and Specifications

## ■ Ratings

Operating power	Non-isolated power supply	24 VDC (1 W)
	Isolated power supply	24 VAC (4 VA), 100 to 115 VAC (4 VA), 200 to 230 VAC (5 VA)
Operation (AL1 and AL2)	Operating value setting range	10% to 100% of maximum rated input value
	Operating value	100% operation at set value
Reset (HYS.)	Hysteresis	5% of operating value (fixed)
	Resetting method	Manual reset/automatic reset (switchable) Manual reset: Turn OFF operating power for 1 s or longer.
Operating time (T)	0.1 to 30 s (Value when input rapidly changes from 0% to 120%.)	
Power ON lock (LOCK)	1 s or 5 s error $\pm 0.5$ s (Value when input rapidly changes from 0% to 100%. The operating time is the shortest at this point.)	
Repeat accuracy	$\pm 10\%$ (rdg) of operating value	
Time error	$\pm 10\%$ of set value (Minimum error: 50 ms)	
Input frequency	40 to 500 Hz	
Input impedance	K8AB-VW1: 9 k $\Omega$ min. K8AB-VW2: 100 k $\Omega$ min. K8AB-VW3: 1 M $\Omega$ min.	
Indicators	Power (PWR): Green LED, Relay output (RY): Yellow LED, Alarm outputs (ALM1/2): Red LED	
Output relays	Two SPDT relays (6 A at 250 VAC, resistive load), Normally closed operation (normally ON) (separate outputs possible for overvoltages and undervoltages)	

## ■ Specifications

Ambient operating temperature	-20 to 60°C (with no condensation or icing)	
Storage temperature	-40 to 70°C (with no condensation or icing)	
Ambient operating humidity	25% to 85%	
Storage humidity	25% to 85%	
Altitude	2,000 m max.	
Operating voltage range	85% to 110% of rated operating voltage	
Rated power supply frequency	50/60 Hz $\pm 5$ Hz (AC power supply)	
Output relays	Resistive load	6 A at 250 VAC ( $\cos \phi = 1$ ) 6 A at 30 VDC (L/R = 0 ms)
	Inductive load	1 A at 250 VAC ( $\cos \phi = 0.4$ ) 1 A at 30 VDC (L/R = 7 ms)
	Minimum load	10 mA at 5 VDC
	Maximum contact voltage	250 VAC
	Maximum contact current	6 A AC
	Maximum switching capacity	1,500 VA
	Mechanical life	10,000,000 operations
	Electrical life	Make: 50,000 times, Break: 30,000 times
Standards	Approved standards	EN60255-5 and EN60255-6
	Application standards	EN61326 and EN60664-1 (pollution level 2, overvoltage category III)
Terminal screw tightening torque	1.2 N·m	
Crimp terminals	Two solid wires of 2.5 mm <sup>2</sup> , two crimp terminals of 1.5 mm <sup>2</sup> with insulation sleeves, can be tightened together	
Insulation resistance	20 M $\Omega$ (at 500 V) between charged terminals and exposed uncharged parts 20 M $\Omega$ (at 500 V) between any charged terminals (i.e., between input, output, and power supply terminals)	
Degree of protection	Terminal section: IP20, Rear case: IP40	
Case color	Munsell 5Y8/1 (ivory)	
Case material	ABS resin (self-extinguishing resin) UL94-V0	
Weight	200 g	
Mounting	Mounted to DIN Track or via M4 screws	
Dimensions	22.5 (W) x 90 (H) x 100 (D) mm	



# Connections

## ■ Wiring Diagram

### Overvoltage and Undervoltage Operation Diagram

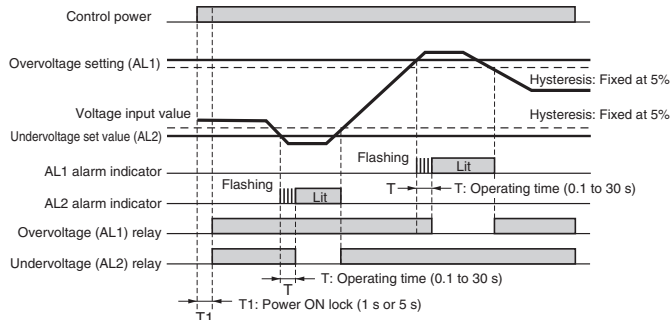

- Note:**
1. The K8AB-VW output relay is normally operative.
  2. The power ON lock prevents unnecessary alarms from being generated during the instable period when the power is first turned on. There is no relay output during timer operation.

### Overvoltage and Undervoltage Operation Diagram (Undervoltage Pre-alarm Mode)

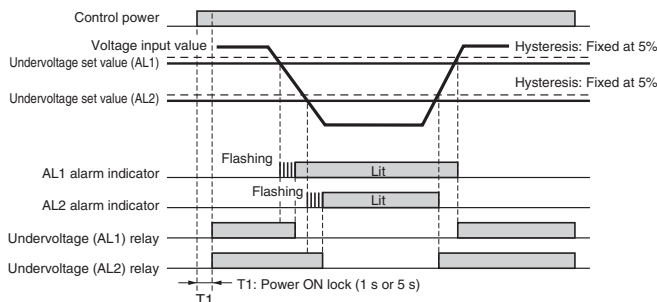

- Note:**
1. The K8AB-VW output relay is normally operative.
  2. The power ON lock prevents unnecessary alarms from being generated during the instable period when the power is first turned on. There is no relay output during timer operation.

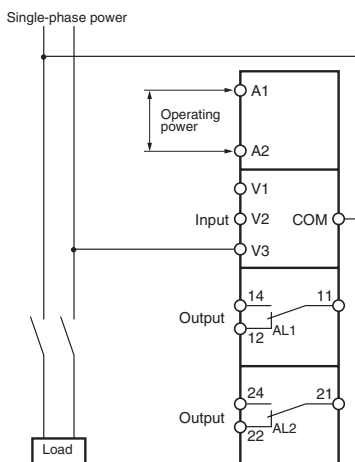

### Overvoltage and Undervoltage Operation Diagram (Overvoltage Pre-alarm Mode)

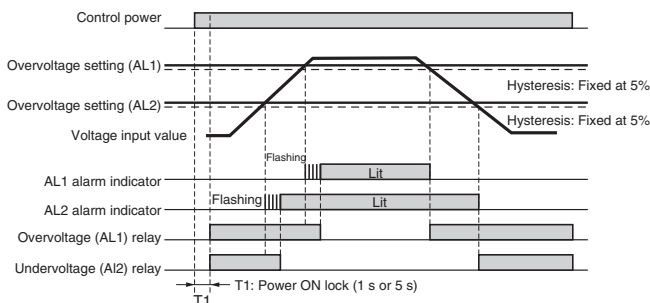

- Note:**
1. The K8AB-VW output relay is normally operative.
  2. The power ON lock prevents unnecessary alarms from being generated during the instable period when the power is first turned on. There is no relay output during timer operation.

# Nomenclature

## ■ Front

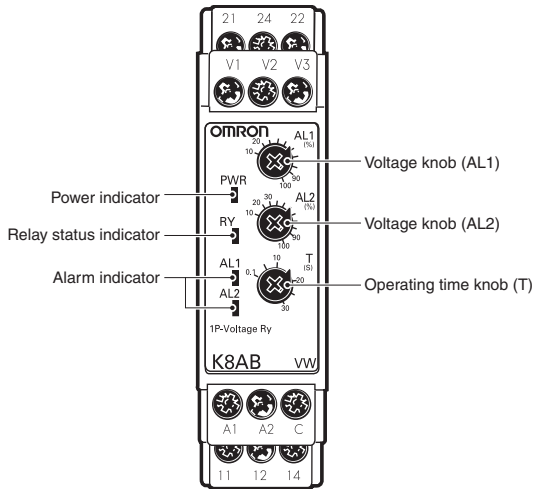

## Indicators

Item	Meaning
Power indicator (PWR: Green)	Lit when power is being supplied.
Relay status indicator (RY: Yellow)	Lit when relay operates (Not light when both AL1 and AL2 are in error status) (Normally lit)
Alarm indicators (AL1 and AL2: Red)	Lit when there is an overvoltage or undervoltage. The indicator flashes to indicate the error status after the input has exceeded the threshold value while the operating time is being clocked.

## Setting Knobs

Item	Usage
Voltage knob (AL1)	Used to set the voltage to 10% to 100% of maximum rated input voltage.
Voltage knob (AL2)	Used to set the voltage to 10% to 100% of maximum rated input voltage.
Operating time knob (T)	Used to set the operating time to 0.1 to 30 s.

## ■ Function Selection DIP Switch

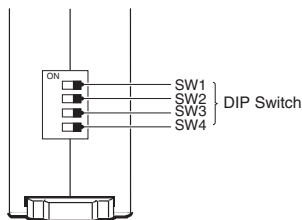

## DIP Switch Functions

SW1	Function	Function		Default
		Setting	Time	
SW1	Operating power ON lock time	OFF	1 s	OFF
		ON	5 s	
SW2	Resetting method	OFF	Manual reset	OFF
		ON	Automatic reset	

SW3	SW4	Function	Default	
			SW3	SW4
OFF	OFF	Operating mode AL1: Overvoltage, AL2: Undervoltage	OFF	OFF
ON	OFF	AL1: Overvoltage, AL2: Overvoltage		
OFF	ON	AL1: Undervoltage, AL2: Undervoltage		
ON	ON	AL1: Overvoltage, AL2: Undervoltage		

# Phase-sequence Phase-loss Relay K8AB-PH

**Ideal for phase sequence and phase loss monitoring for industrial facilities and equipment.**

- Simultaneously monitor phase sequence and phase loss for three-phase 3-wire power supplies.
- One SPDT output relay, 6 A at 250 VAC (resistive load).
- Relay warning status easily monitoring using LED indicator.



**NEW**

## Ordering Information

### ■ List of Models

Model	Rated input voltage (See note.)	Function
K8AB-PH1	200 to 500 VAC	Phase sequence and phase loss monitoring

**Note:** The power supply is shared with the rated input voltage.

# Ratings and Specifications

## ■ Ratings

Rated input voltage	Non-isolated	200 to 500 VAC (15 VA)
Phase sequence, phase loss operating time		0.1 s max. (value when rated operating voltage changes quickly from 0% to 100%) (Relays are normally ON and turn OFF for phase sequence or loss phase errors.)
Resetting method		Automatic reset
Input frequency		45 to 65 Hz
Input impedance		100 k $\Omega$ min.
Indicators		Power (PWR): Green LED, Relay output (RY): Yellow LED
Output relays		One SPDT relay (6 A at 250 VAC, resistive load)

## ■ Specifications

Ambient operating temperature		-20 to 60°C (with no condensation or icing)
Storage temperature		-40 to 70°C (with no condensation or icing)
Ambient operating humidity		25% to 85%
Storage humidity		25% to 85%
Altitude		2,000 m max.
Voltage fluctuation range		85% to 110% of rated input voltage
Input frequency		50/60 Hz $\pm$ 5 Hz (AC power supply)
Output relays	Resistive load	6 A at 250 VAC ( $\cos \phi = 1$ ) 6 A at 30 VDC (L/R = 0 ms)
	Inductive load	1 A at 250 VAC ( $\cos \phi = 0.4$ ) 1 A at 30 VDC (L/R = 7 ms)
	Minimum load	10 mA at 5 VDC
	Maximum contact voltage	250 VAC
	Maximum contact current	6 A AC
	Maximum switching capacity	1,500 VA
	Mechanical life	10,000,000 operations
	Electrical life	Make: 50,000 times, Break: 30,000 times
Standards	Approved standards	EN60255-5 and EN60255-6
	Application standards	EN61326 and EN60664-1 (pollution level 2, overvoltage category III)
Terminal screw tightening torque		1.2 N·m
Crimp terminals		Two solid wires of 2.5 mm <sup>2</sup> , two crimp terminals of 1.5 mm <sup>2</sup> with insulation sleeves, can be tightened together
Insulation resistance		20 M $\Omega$ (at 500 V) between charged terminals and exposed uncharged parts 20 M $\Omega$ (at 500 V) between any charged terminals (i.e., between input, output, and power supply terminals)
Degree of protection		Terminal section: IP20, Rear case: IP40
Case color		Munsell 5Y8/1 (ivory)
Case material		ABS resin (self-extinguishing resin) UL94-V0
Weight		200 g
Mounting		Mounted to DIN Track or via M4 screws
Dimensions		22.5 (W) x 90 (H) x 100 (D) mm

# Connections

## ■ Wiring Diagram

### Phase Sequence and Phase Loss Operation Diagram

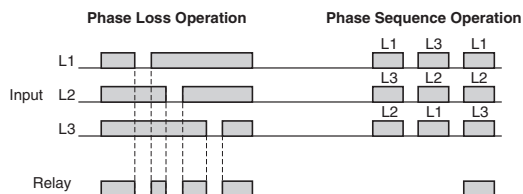

- Note:**
1. Motor load phase loss cannot be detected. To detect motor load phase loss, use the K8AB-PM or K8AB-PA.
  2. The K8AB-PH output relay is normally operative.

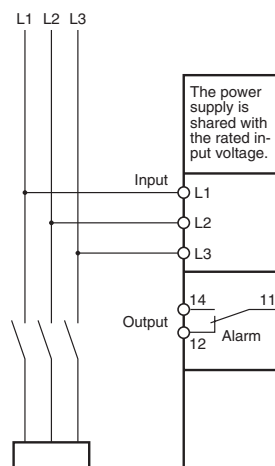

## Nomenclature

### ■ Front

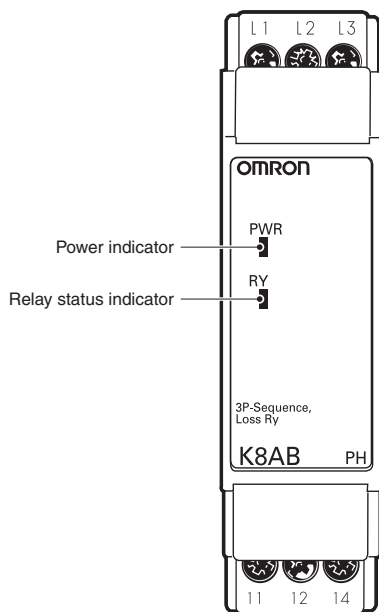

### Indicators

Item	Meaning
Power indicator (PWR: Green)	Lit when power is being supplied.
Relay status indicator (RY: Yellow)	Lit when relay is operating (normally lit).

# Three-phase Phase-sequence Phase-loss Relay K8AB-PM

**Ideal for monitoring 3-phase power supplies for industrial facilities and equipment.**

- Monitor overvoltages, undervoltages, phase sequence, and phase loss for three-phase 3-wire or 4-wire power supplies with just one Unit.  
Switch setting for 3-phase 3-wire or 3-phase 4-wire power supply.
- Two SPDT output relays, 6 A at 250 VAC (resistive load).  
Separate outputs possible for overvoltages and undervoltages.
- World-wide power specifications supported by one Unit (switchable).
- Relay warning status easily monitoring using LED indicator.



## Ordering Information

### ■ List of Models

Model	Rated input (See note 2.)	
K8AB-PM1	3-phase 3-wire mode	200, 220, 230, 240 VAC
	3-phase 4-wire mode	115, 127, 133, 138 VAC
K8AB-PM2	3-phase 3-wire mode	380, 400, 415, 480 VAC
	3-phase 4-wire mode	220, 230, 240, 277 VAC

- Note:** 1. Three-phase 3-wire or 4-wire and the input range are switched using a switch.  
2. The power supply is shared with the rated input voltage.

# Ratings and Specifications

## ■ Ratings

Rated input voltage	K8AB-PM1	Three-phase, three-wire mode: 200, 220, 230, 240 VAC Three-phase, four-wire mode: 115, 127, 133, 138 VAC
	K8AB-PM2	Three-phase, three-wire mode: 380, 400, 415, 480 VAC Three-phase, four-wire mode: 220, 230, 240, 277 VAC
Operation (overvoltage or undervoltage)	Operating value setting range	Overvoltage = -30% to 25% of maximum rated input voltage Undervoltage = -30% to 25% of maximum rated input voltage Note: The rated input voltage is switched with a switch.
	Operating value	100% operation at set value
Reset (HYS.)	Hysteresis	5% of operating value (fixed)
	Resetting method	Automatic reset
Operating time (T)	Overvoltage/undervoltage	0.1 to 30 s (Value when input rapidly changes from 0% to 120%.)
	Phase sequence, phase loss	0.1 max. (Value when input rapidly changes from 0% to 100%.)
Power ON lock (LOCK)		1 s or 5 s error $\pm 0.5$ s (Value when input rapidly changes from 0% to 100%. The operating time is the shortest at this point.)
Repeat accuracy		$\pm 10\%$ (rdg) of operating value
Time error		$\pm 10\%$ of set value (Minimum error: 50 ms)
Input frequency		45 to 65 Hz
Input impedance		100 k $\Omega$ min.
Indicators		Power (PWR): Green LED, Relay output (RY): Yellow LED, Alarm outputs (ALM1/2): Red LED
Output relays		Two SPDT relays (6 A at 250 VAC, resistive load), Normally closed operation (normally ON) (separate outputs possible for overvoltages and undervoltages)

## ■ Specifications

Ambient operating temperature		-20 to 60°C (with no condensation or icing)
Storage temperature		-40 to 70°C (with no condensation or icing)
Ambient operating humidity		25% to 85%
Storage humidity		25% to 85%
Altitude		2,000 m max.
Voltage fluctuation range		85% to 110% of rated input voltage
Input frequency		50/60 Hz $\pm 5$ Hz (AC power supply)
Output relays	Resistive load	6 A at 250 VAC ( $\cos \phi = 1$ ) 6 A at 30 VDC (L/R = 0 ms)
	Inductive load	1 A at 250 VAC ( $\cos \phi = 0.4$ ) 1 A at 30 VDC (L/R = 7 ms)
	Minimum load	10 mA at 5 VDC
	Maximum contact voltage	250 VAC
	Maximum contact current	6 A AC
	Maximum switching capacity	1,500 VA
	Mechanical life	10,000,000 operations
	Electrical life	Make: 50,000 times, Break: 30,000 times
Standards	Approved standards	EN60255-5 and EN60255-6
	Application standards	EN61326 and EN60664-1 (pollution level 2, overvoltage category III)
Terminal screw tightening torque		1.2 N·m
Crimp terminals		Two solid wires of 2.5 mm <sup>2</sup> , two crimp terminals of 1.5 mm <sup>2</sup> with insulation sleeves, can be tightened together
Insulation resistance		20 M $\Omega$ (at 500 V) between charged terminals and exposed uncharged parts 20 M $\Omega$ (at 500 V) between any charged terminals (i.e., between input, output, and power supply terminals)
Degree of protection		Terminal section: IP20, Rear case: IP40
Case color		Munsell 5Y8/1 (ivory)
Case material		ABS resin (self-extinguishing resin) UL94-V0
Weight		200 g
Mounting		Mounted to DIN Track or via M4 screws
Dimensions		22.5 (W) x 90 (H) x 100 (D) mm

# Connections

## ■ Wiring Diagram

### Overvoltage/Undervoltage and Phase Sequence/Phase Loss Operation Diagram

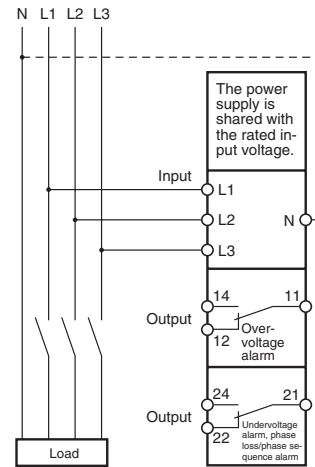
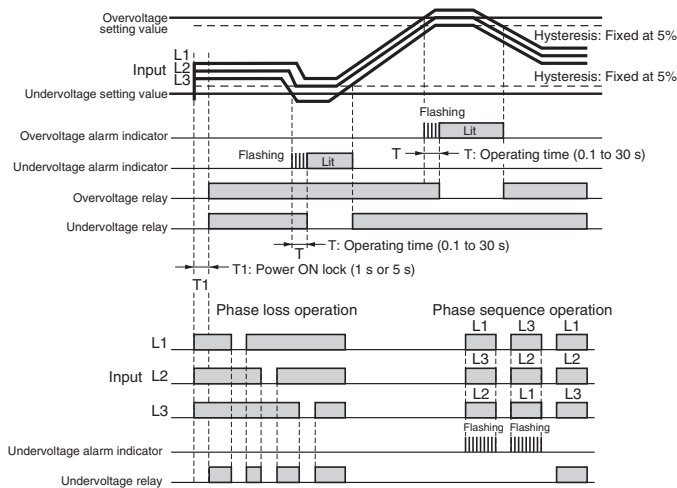

- Note:**
1. The K8AB-PM output relay is normally operative.
  2. The power ON lock prevents unnecessary alarms from being generated during the instable period when the power is first turned on. There is no relay output during timer operation.

## Nomenclature

### ■ Front

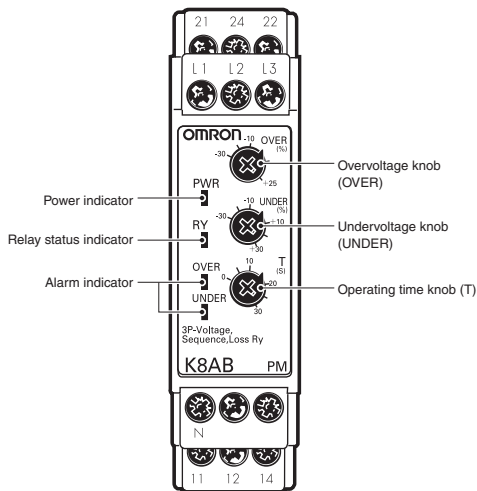

### Indicators

Item	Meaning
Power indicator (PWR: Green)	Lit when power is being supplied.
Relay status indicator (RY: Yellow)	Lit when relay is operating (normally lit).
Alarm indicator (ALM: Red)	Overvoltage: Red Lit for overvoltage. The indicator flashes to indicate the error status after the overvoltage has exceeded the threshold value while the operating time is being clocked.
	Undervoltage: Red Lit for an undervoltage or phase loss. The indicator flashes to indicate the error status after the undervoltage has exceeded the threshold value while the operating time is being clocked. • Lit for phase sequence error.

### Setting Knobs

Item	Usage
Overvoltage knob (OVER)	Used to set the voltage to -30% to 25% of the rated input voltage.
Undervoltage knob (UNDER)	Used to set the voltage to -30% to 25% of the rated input voltage.
Operating time knob (T)	Used to set the operating time to 0.1 to 30 s.



## ■ Function Selection DIP Switch

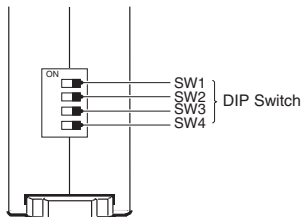

### DIP Switch Functions

SW1	Function	Function		Default
		Setting	Value	
SW1	Power ON lock time	OFF	1 s	OFF
		ON	5 s	
SW2	Monitoring mode selector	OFF	3-phase 3-wire power monitoring mode	OFF
		ON	3-phase 4-wire power monitoring mode	

SW3	SW4	Function	Function		Default	
			3-phase 3-wire mode	3-phase 4-wire mode	SW3	SW4
OFF	OFF	Rated input voltage switch (K8AB-PM1)	200 VAC	115 VAC	OFF	OFF
ON	OFF		220 VAC	127 VAC		
OFF	ON		230 VAC	133 VAC		
ON	ON		240 VAC	138 VAC		
OFF	OFF	Rated input voltage switch (K8AB-PM2)	380 VAC	220 VAC	OFF	OFF
ON	OFF		400 VAC	230 VAC		
OFF	ON		415 VAC	240 VAC		
ON	ON		480 VAC	277 VAC		

# Three-phase Asymmetry and Phase-sequence Phase-loss Relay K8AB-PA

**Ideal for 3-phase voltage asymmetry monitoring for industrial facilities and equipment.**

- Monitor voltage asymmetry, phase sequence, and phase loss for three-phase 3-wire or 4-wire power supplies with just one Unit.  
Switch setting for 3-phase 3-wire or 3-phase 4-wire power supply.
- One SPDT output relay, 6 A at 250 VAC (resistive load).
- World-wide power specifications supported by one Unit (switchable).
- Relay warning status easily monitoring using LED indicator.



## Ordering Information

### ■ List of Models

Model	Rated input (See note 2.)	
K8AB-PA1	3-phase 3-wire mode	AC 200, 220, 230, 240
	3-phase 4-wire mode	AC 115, 127, 133, 138
K8AB-PA2	3-phase 3-wire mode	AC 380, 400, 415, 480
	3-phase 4-wire mode	AC 220, 230, 240, 277

- Note:** 1. Three-phase 3-wire or 4-wire and the input range are switched using a switch.  
2. The power supply is shared with the rated input voltage.

# Ratings and Specifications

## ■ Ratings

Rated input voltage	K8AB-PA1	Three-phase, three-wire mode: 200, 220, 230, 240 VAC Three-phase, four-wire mode: 115, 127, 133, 138 VAC
	K8AB-PA2	Three-phase, three-wire mode: 380, 400, 415, 480 VAC Three-phase, four-wire mode: 220, 230, 240, 277 VAC
Asymmetry operation (ASY.)	Operating value setting range	Asymmetry rate: 2% to 22%
	Operating value	100% operation at set value Asymmetry operating value = Rated input voltage x Asymmetry set value [%] The asymmetry operation will function when the difference between the highest and lowest voltage phases equals or exceeds the asymmetry operating value.
Reset (HYS.)	Hysteresis	5% of operating value (fixed)
	Resetting method	Automatic reset
Operating time (T)	Asymmetry	0.1 s to 30 s (Value when input rapidly changes from 0% to 120%.)
	Phase sequence, phase loss	0.1 s max. (Value when input rapidly changes from 0% to 100%.)
Power ON lock (LOCK)		1 s or 5 s (Value when input rapidly changes from 0% to 100%. The operating time is the shortest at this point.)
Repeat accuracy		±10% (rdg) of operating value
Time error		±10% of set value (Minimum error: 50 ms)
Input frequency		45 to 65 Hz
Input impedance		100 kΩ min.
Indicators		Power (PWR): Green LED, Relay output (RY): Yellow LED, Alarm outputs (ALM1/2): Red LED
Output relays		One SPDT relay (6 A at 250 VAC, resistive load) , normally closed operation (normally ON)

## ■ Specifications

Ambient operating temperature		-20 to 60°C (with no condensation or icing)
Storage temperature		-40 to 70°C (with no condensation or icing)
Ambient operating humidity		25% to 85%
Storage humidity		25% to 85%
Altitude		2,000 m max.
Voltage fluctuation range		85% to 110% of rated input voltage
Input frequency		50/60 Hz ±5 Hz (AC power supply)
Output relays	Resistive load	6 A at 250 VAC (cos φ = 1) 6 A at 30 VDC (L/R = 0 ms)
	Inductive load	1 A at 250 VAC (cos φ = 0.4) 1 A at 30 VDC (L/R = 7 ms)
	Minimum load	10 mA at 5 VDC
	Maximum contact voltage	250 VAC
	Maximum contact current	6 A AC
	Maximum switching capacity	1,500 VA
	Mechanical life	10,000,000 operations
	Electrical life	Make: 50,000 times, Break: 30,000 times
Standards	Approved standards	EN60255-5 and EN60255-6
	Application standards	EN61326 and EN60664-1 (pollution level 2, overvoltage category III)
Terminal screw tightening torque		1.2 N·m
Crimp terminals		Two solid wires of 2.5 mm <sup>2</sup> , two crimp terminals of 1.5 mm <sup>2</sup> with insulation sleeves, can be tightened together
Insulation resistance		20 MΩ (at 500 V) between charged terminals and exposed uncharged parts 20 MΩ (at 500 V) between any charged terminals (i.e., between input, output, and power supply terminals)
Degree of protection		Terminal section: IP20, Rear case: IP40
Case color		Munsell 5Y8/1 (ivory)
Case material		ABS resin (self-extinguishing resin) UL94-V0
Weight		200 g
Mounting		Mounted to DIN Track or via M4 screws
Dimensions		22.5 (W) x 90 (H) x 100 (D) mm

# Connections

## ■ Wiring Diagram

### Voltage Asymmetry and Phase Sequence/Phase Loss Operation Diagram

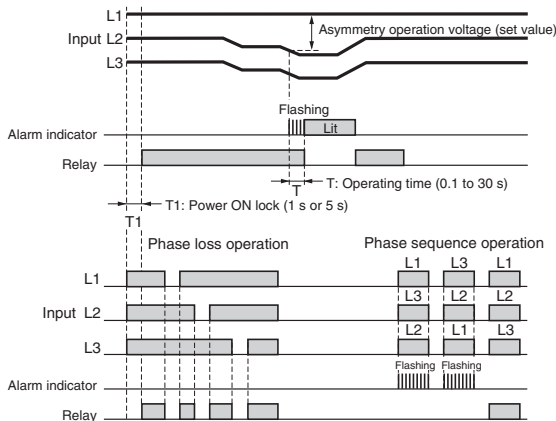

**Note:** 1. The K8AB-PA output relay is normally operative.  
 2. The power ON lock prevents unnecessary alarms from being generated during the instable period when the power is first turned on. There is no relay output during timer operation.

**Calculating the Asymmetry Operating Voltage**  
 Asymmetry operation condition = (Highest voltage – Lowest voltage) > Asymmetry operating voltage  
 Asymmetry operating voltage = Rated input voltage (V) × Asymmetry set value (%)  
**Note:** The rated input voltage is selected and set with the DIP switch.

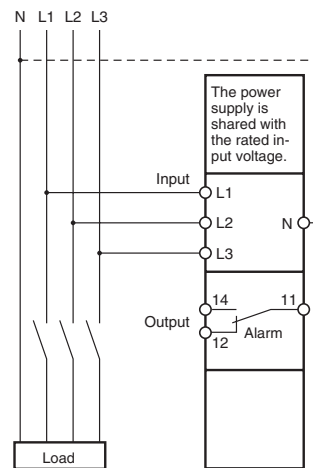

## Nomenclature

### ■ Front

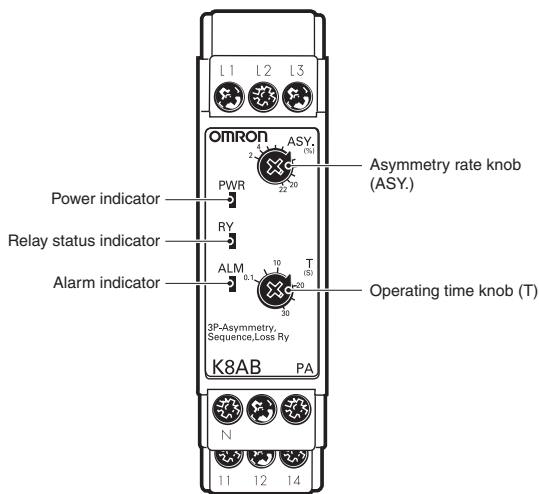

### Indicators

Item	Meaning
Power indicator (PWR: Green)	Lit when power is being supplied.
Relay status indicator (RY: Yellow)	Lit when relay is operating (normally lit).
Alarm indicator (ALM: Red)	Asymmetry voltage error indicator The indicator flashes to indicate the error status after the input has exceeded the threshold value while the operating time is being clocked.

### Setting Knobs

Item	Usage
Asymmetry rate knob (SV)	Used to set the asymmetry rate to 2% to 22%.
Operating time knob (T)	Used to set the operating time to 0.1 to 30 s.

■ Bottom

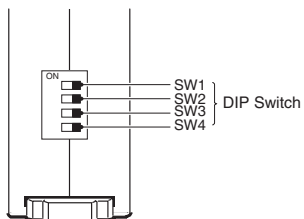

**DIP Switch Functions**

	Function		Default	
<b>SW1</b>	Power ON lock time	OFF	1 s	OFF
		ON	5 s	
<b>SW2</b>	Monitoring mode selector	OFF	3-phase 3-wire power monitoring mode	OFF
		ON	3-phase 4-wire power monitoring mode	

<b>SW3</b>	<b>SW4</b>	Function	Default			
			<b>SW3</b>	<b>SW4</b>		
			<b>3-phase 3-wire mode</b>	<b>3-phase 4-wire mode</b>		
OFF	OFF	Rated input voltage switch (K8AB-PA1)	200 VAC	115 VAC	OFF	OFF
ON	OFF		220 VAC	127 VAC		
OFF	ON		230 VAC	133 VAC		
ON	ON		240 VAC	138 VAC		
OFF	OFF	Rated input voltage switch (K8AB-PA2)	380 VAC	220 VAC	OFF	OFF
ON	OFF		400 VAC	230 VAC		
OFF	ON		415 VAC	240 VAC		
ON	ON		480 VAC	277 VAC		

# Three-phase Voltage Relay K8AB-PW

**Ideal for monitoring 3-phase power supplies for industrial facilities and equipment.**

- Monitor overvoltages and undervoltages for three-phase 3-wire or 4-wire power supplies.  
Switch setting for 3-phase 3-wire or 3-phase 4-wire power supply.
- Two SPDT output relays, 6 A at 250 VAC (resistive load).  
Separate outputs possible for overvoltages and undervoltages.
- World-wide power specifications supported by one Unit (switchable).
- Relay warning status easily monitoring using LED indicator.



## Ordering Information

### ■ List of Models

Model	Rated input (See note 2.)	
K8AB-PW1	3-phase 3-wire mode	200, 220, 230, 240 VAC
	3-phase 4-wire mode	115, 127, 133, 138 VAC
K8AB-PW2	3-phase 3-wire mode	380, 400, 415, 480 VAC
	3-phase 4-wire mode	220, 230, 240, 277 VAC

- Note:** 1. Three-phase 3-wire or 4-wire and the input range are switched using a switch.  
2. The power supply is shared with the rated input voltage.

# Ratings and Specifications

## ■ Ratings

Rated input voltage	K8AB-PW1	Three-phase, three-wire mode: 200, 220, 230, 240 VAC Three-phase, four-wire mode: 115, 127, 133, 138 VAC
	K8AB-PW2	Three-phase, three-wire mode: 380, 400, 415, 480 VAC Three-phase, four-wire mode: 220, 230, 240, 277 VAC
Operation (overvoltage and undervoltage)	Operating value setting range	Overvoltage = -30% to 25% of maximum rated input voltage Undervoltage = -30% to 25% of maximum rated input voltage Note: The rated input voltage is switched with a switch.
	Operating value	100% operation at set value
Reset (HYS.)	Hysteresis	5% of operating value (fixed)
	Resetting method	Automatic reset
Operating time (T)	Overvoltage/undervoltage	0.1 to 30 s (Value when input rapidly changes from 0% to 120%.)
Power ON lock (LOCK)		1 s or 5 s (Value when input rapidly changes from 0% to 100%. The operating time is the shortest at this point.)
Repeat accuracy		±10% (rdg) of operating value
Time error		±10% of set value (Minimum error: 50 ms)
Input frequency		45 to 65 Hz
Input impedance		100 kΩ min.
Indicators		Power (PWR): Green LED, Relay output (RY): Yellow LED, Alarm outputs (ALM1/2): Red LED
Output relays		Two SPDT relays (6 A at 250 VAC, resistive load) Normally closed operation (normally ON) (separate outputs possible for overvoltages and undervoltages)

## ■ Specifications

Ambient operating temperature		-20 to 60°C (with no condensation or icing)
Storage temperature		-40 to 70°C (with no condensation or icing)
Ambient operating humidity		25% to 85%
Storage humidity		25% to 85%
Altitude		2,000 m max.
Voltage fluctuation range		85% to 110% of rated input voltage
Input frequency		50/60 Hz ±5 Hz (AC power supply)
Output relays	Resistive load	6 A at 250 VAC (cos φ = 1) 6 A at 30 VDC (L/R = 0 ms)
	Inductive load	1 A at 250 VAC (cos φ = 0.4) 1 A at 30 VDC (L/R = 7 ms)
	Minimum load	10 mA at 5 VDC
	Maximum contact voltage	250 VAC
	Maximum contact current	6 A AC
	Maximum switching capacity	1,500 VA
	Mechanical life	10,000,000 operations
	Electrical life	Make: 50,000 times, Break: 30,000 times
Standards	Approved standards	EN60255-5 and EN60255-6
	Application standards	EN61326 and EN60664-1 (pollution level 2, overvoltage category III)
Terminal screw tightening torque		1.2 N·m
Crimp terminals		Two solid wires of 2.5 mm <sup>2</sup> , two crimp terminals of 1.5 mm <sup>2</sup> with insulation sleeves, can be tightened together
Insulation resistance		20 MΩ (at 500 V) between charged terminals and exposed uncharged parts 20 MΩ (at 500 V) between any charged terminals (i.e., between input, output, and power supply terminals)
Degree of protection		Terminal section: IP20, Rear case: IP40
Case color		Munsell 5Y8/1 (ivory)
Case material		ABS resin (self-extinguishing resin) UL94-V0
Weight		200 g
Mounting		Mounted to DIN Track or via M4 screws
Dimensions		22.5 (W) x 90 (H) x 100 (D) mm

# Connections

## ■ Wiring Diagram

### Overvoltage and Undervoltage Operation Diagram

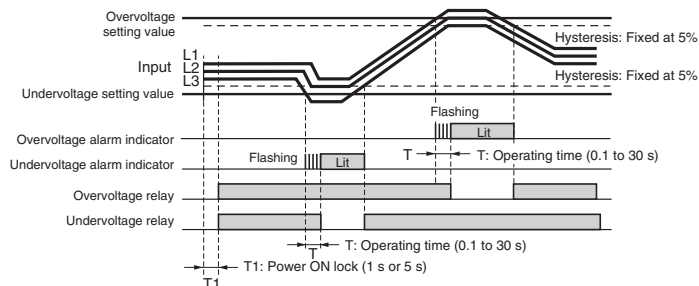

- Note:**
1. The K8AB-PW output relay is normally operative.
  2. The power ON lock prevents unnecessary alarms from being generated during the instable period when the power is first turned on. There is no relay output during timer operation.

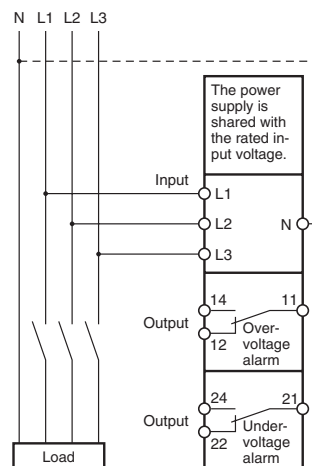

## Nomenclature

### ■ Front

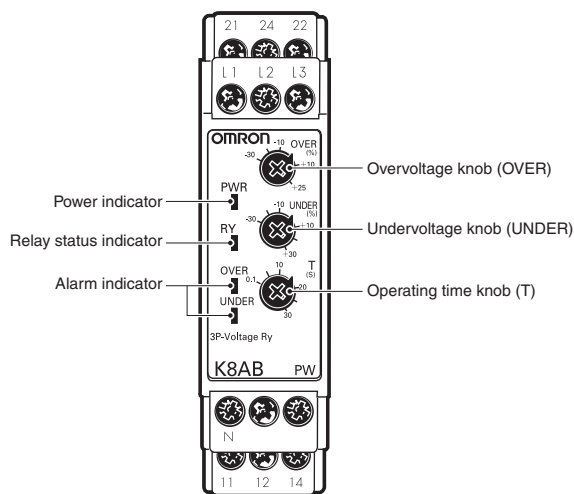

### Indicators

Item	Meaning	
Power indicator (PWR: Green)	Lit when power is being supplied.	
Relay status indicator (RY: Yellow)	Lit when relay is operating (normally lit).	
Alarm indicator (ALM: Red)	Overvoltage: Red	The indicator flashes to indicate the error status after the overvoltage has exceeded the threshold value while the operating time is being clocked.
	Undervoltage: Red	The indicator flashes to indicate the error status after the undervoltage has exceeded the threshold value while the operating time is being clocked.

### Setting Knobs

Item	Usage
Overvoltage knob (OVER)	Used to set the voltage to -30% to 25% of the rated input voltage.
Undervoltage knob (UNDER)	Used to set the voltage to -30% to 25% of the rated input voltage.
Operating time knob (T)	Used to set the operating time to 0.1 to 30 s.



■ Bottom

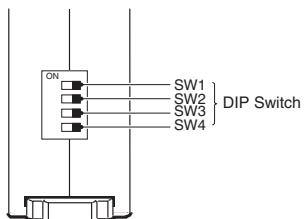

**DIP Switch Functions**

		Function		Default
SW1	Power ON lock time	OFF	1 s	OFF
		ON	5 s	
SW2	Monitoring mode selector	OFF	3-phase 3-wire power monitoring mode	OFF
		ON	3-phase 4-wire power monitoring mode	

SW3	SW4	Function	Function		Default	
			3-phase 3-wire mode	3-phase 4-wire mode	SW3	SW4
OFF	OFF	Rated input voltage switch (K8AB-PW)	200 VAC	115 VAC	OFF	OFF
ON	OFF		220 VAC	127 VAC		
OFF	ON		230 VAC	133 VAC		
ON	ON		240 VAC	138 VAC		
OFF	OFF	Rated input voltage switch (K8AB-PW)	380 VAC	220 VAC	OFF	OFF
ON	OFF		400 VAC	230 VAC		
OFF	ON		415 VAC	240 VAC		
ON	ON		480 VAC	277 VAC		

# Conductive Level Controller 61F-D21T-V1

**Ideal for level control for industrial facilities and equipment.**

- Outputs can be set to self-hold at ON or OFF using self-holding circuits.
- Sensitivity adjustment of operating resistance from 10 to 100 k $\Omega$  for application to a wide range of liquids.
- Delay timer to prevent relay contact chattering caused by waves.
- CE marking, cUL application pending.



## Ordering Information

### ■ List of Models

Model	Rated voltage
61F-D21T-V1	24 VAC 50/60 Hz
	115 VAC 50/60 Hz
	220 to 230 VAC 50/60 Hz

## Specifications

<b>Rated voltage</b>	24 VAC, 115 VAC, 220 to 230 VAC
<b>Operating voltage range</b>	85% to 110% of rated voltage
<b>Voltage between electrodes</b>	6 VAC p-p (approx. 20 Hz)
<b>Power consumption</b>	Approx. 5 VA max.
<b>Operating resistance</b>	10 k $\Omega$ to 100 k $\Omega$ (variable)
<b>Reset resistance</b>	250 k $\Omega$ max.
<b>Response time</b>	Approx. 0.1 to 10 s (variable)
<b>Cable length</b>	100 m max. with completely insulated (600 V) cable with 3 conductors (0.75 mm <sup>2</sup> )
<b>Control output</b>	6 A at 250 VAC for resistive load at 20°C, 1 A at 250 VAC for inductive load $\cos\phi = 0.4$ at 20°C
<b>Indicators</b>	Green LED: Power, Yellow LED: Control output
<b>Ambient temperature</b>	Operating: -20 to 60°C, Storage: -30 to 70°C (with no condensation or icing)
<b>Ambient humidity</b>	Operating: 25% to 85%, Storage: 25% to 85%
<b>Elevation</b>	2,000 m max.
<b>Insulation resistance</b>	100 M $\Omega$ min. (at 500 VDC) between power supply section, electrode section, and contact section
<b>Dielectric strength</b>	2,000 VAC 50/60 Hz for 1 min between power source section, electrode section, and contact section
<b>Vibration resistance</b>	Vibration of 10 to 55 Hz and acceleration of 50 m/s <sup>2</sup> for 5 min 10 times each in X, Y, and Z directions
<b>Shock resistance</b>	100 m/s <sup>2</sup> 3 times each in 6 directions on 3 axes

# Connections

## ■ Operation Diagram

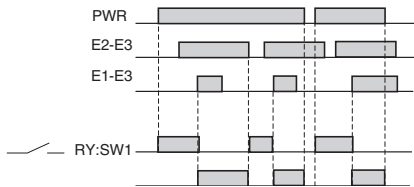

## ■ Wiring Diagram

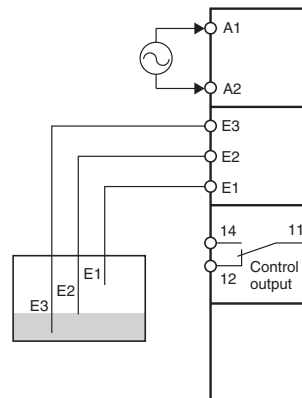

# Nomenclature

## ■ Front

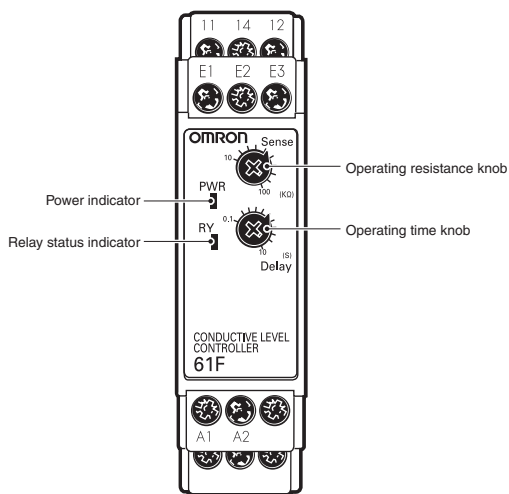

## ■ Bottoms

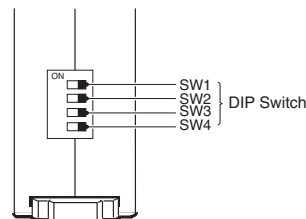

## DIP Switch Functions

SW	Function	Function		Default
		OFF	ON	
SW1	Supply/drainage selection	OFF	Automatic liquid supply operation	OFF
		ON	Automatic liquid drainage operation	
SW2	Not used.	OFF	Not used.	OFF
		ON	Not used.	
SW3	Not used.	OFF	Not used.	OFF
		ON	Not used.	
SW4	Not used.	OFF	Not used.	OFF
		ON	Not used.	

## Indicators

Item	Meaning
Power indicator (PWR: Green)	Lit when power is being supplied.
Relay status indicator (RY: Yellow)	Lit when relay is operating.

## Setting Knobs

Item	Usage
Operating resistance knob	Used to set the operating resistance to 10 to 100 kΩ.
Operating time knob	Use to set the operating time to 0.1 to 10 s.

# K8AB Series General Information

## ■ Dimensions (Unit: mm)

### List of Models

- |         |             |
|---------|-------------|
| K8AB-AS | K8AB-PM     |
| K8AB-VS | K8AB-PA     |
| K8AV-VW | K8AB-PW     |
| K8AB-PH | 61F-D21T-V1 |

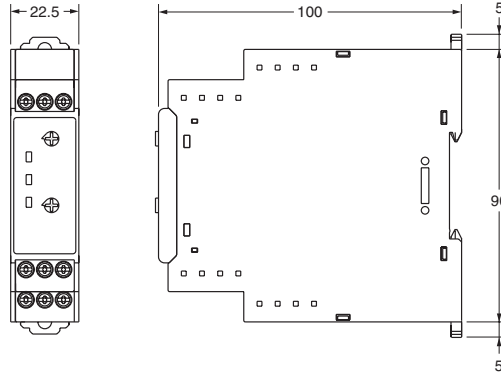
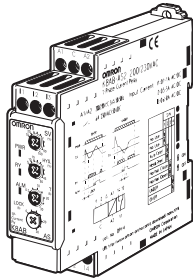

## OMRON CT

### K8AC-CT200L

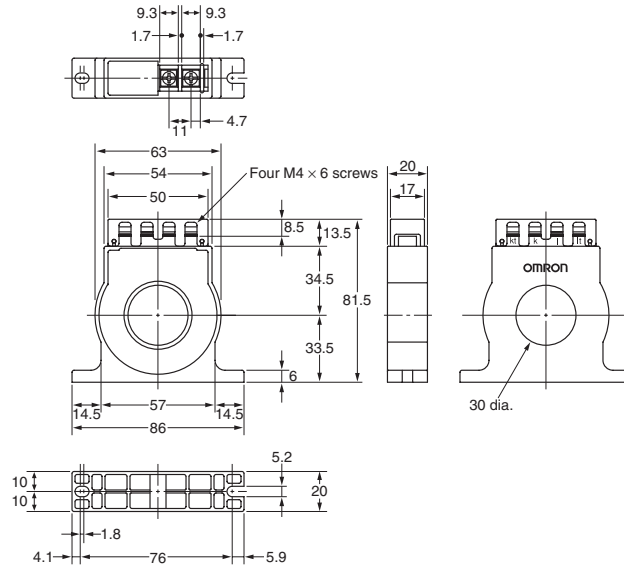
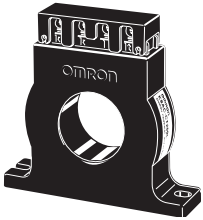

### Mounting Hole Dimensions

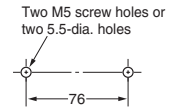

# K8AB Series General Information

## ■ Safety Precautions

### Precautions for Safe Use

The following precautions are essential to ensure safety. Always heed these precautions.

1. Do not use or store the Product in the following locations.
2. Mount the Product in the correct direction.
3. Do not touch the terminals when power is being supplied. Electric shock may occasionally occur.
4. Be sure you understand the contents of the Instruction Sheet and handle the Product according to the instructions provided.
5. Check all terminal numbers and polarity when wiring and wire all connections correctly.
6. Tighten terminal screws to the following torque. Recommended tightening torque: 0.54 N·m
7. Use the Product within the specified temperature and humidity ranges.
8. Do not use the Product in locations subject to flammable or explosive gases. Explosions may occasionally occur if the Product is used in such locations.
9. Do not install the Product in any way that would place a load on it.
10. Install an external switch or circuit breaker that complies with applicable IEC60947-1 and IEC60947-3 requirements and label it clearly so that the operator can quickly turn OFF the power.
11. For DC power, use an SELV power supply with overcurrent protection. An SELV power supply is one with double or reinforced insulation between the input and output and an output voltage of 30 Vrms and 42.2 V peak, or 60 VDC maximum.  
Recommended power supply: OMRON S8VS-06024□

### Precautions for Correct Use

#### Application

1. Do not use the Product in the following locations.
  - Locations subject to direct radiant heat from heating equipment
  - Locations subject to vibration or shock
2. Be sure that all settings are suitable for the controlled system. Unexpected operation possibly resulting in machine damage or accidents may result if settings are not suitable.
3. Do not clean the Product with paint thinners or other organic solvents. Use commercial alcohol.
4. Dispose of the Product as industrial waste.
5. Be sure to install the Product in a panel designed so that fire cannot escape to the exterior of the panel.

#### Installation

1. Use the recommended crimp terminals.
2. Do not block the area around the Product so as to interfere with heat dissipation. (The life of the product will be reduced if sufficient cooling space is not provided.)
3. To prevent electric shock, always turn OFF the power supply before starting wiring.
4. To prevent electric shock, always turn OFF the power supply before changing the DIP switch settings.

#### Noise Measures

1. Do not install the Product near equipment that generates high frequencies or surges.
2. When using a noise filter for the power supply, check the voltage and current and connect the noise filter as close as possible to the Product.

3. To prevent inductive noise, separate Product wiring as far as possible from high-voltage or high-current lines. Do not place Product wiring in parallel with or in the same path as high-voltage or high-current lines. Using separate conduits or ducts and shielded cables can also be effective. Operating Methods to Prevent Failure and Malfunction.

### Preventing Failure, Errors, or Malfunction

1. Use a power supply that will reach the rated voltage within 1 s after the power is turned ON.
2. Use operating power, input power, and other power supplies and converters with suitable capacities and rated outputs.
3. Allow only qualified personnel to manage and handle the Product.
4. The distortion in the input waveform for the K8AB-AS, K8AB-PH, K8AB-PA, and K8AB-PM must be 30% max. If the input waveform is distorted beyond this level, it may cause unnecessary operation.  
Do not use the K8AB-VS or K8AB-VW in circuits with waveform distortion. Error will be large due to waveform distortion.
5. Error will be large if the K8AB-AS, K8AB-VS or K8AB-VW is used for thyristor or inverter control.  
The K8AB-PH, K8AB-PM, K8AB-PA, and K8AB-PW cannot be used for thyristor or inverter control.
6. Turn setting knobs from the minimum setting toward the maximum setting.
7. Connect phases in the proper sequence (K8AB-PH, K8AB-PA, K8AB-PM, and K8AB-PW).
8. Phase loss is detected for the K8AB-PH only when the phase loss occurs between the input contact and the power supply. Phase loss is not detected on the load side. Phase loss is detection only when the power is turned ON, and is not detected while power remains ON.
9. Phase loss can be detected only from the input contact to the power supply side by the K8AB-PH, K8AB-PM, and K8AB-PA. Phase loss cannot be detected from the input contact to the load side.

# Warranty and Application Considerations

## Read and Understand this Catalog

Please read and understand this catalog before purchasing the products. Please consult your OMRON representative if you have any questions or comments.

## Warranty and Limitations of Liability

### WARRANTY

OMRON's exclusive warranty is that the products are free from defects in materials and workmanship for a period of one year (or other period if specified) from date of sale by OMRON.

OMRON MAKES NO WARRANTY OR REPRESENTATION, EXPRESS OR IMPLIED, REGARDING NON-INFRINGEMENT, MERCHANTABILITY, OR FITNESS FOR PARTICULAR PURPOSE OF THE PRODUCTS. ANY BUYER OR USER ACKNOWLEDGES THAT THE BUYER OR USER ALONE HAS DETERMINED THAT THE PRODUCTS WILL SUITABLY MEET THE REQUIREMENTS OF THEIR INTENDED USE. OMRON DISCLAIMS ALL OTHER WARRANTIES, EXPRESS OR IMPLIED.

### LIMITATIONS OF LIABILITY

OMRON SHALL NOT BE RESPONSIBLE FOR SPECIAL, INDIRECT, OR CONSEQUENTIAL DAMAGES, LOSS OF PROFITS, OR COMMERCIAL LOSS IN ANY WAY CONNECTED WITH THE PRODUCTS, WHETHER SUCH CLAIM IS BASED ON CONTRACT, WARRANTY, NEGLIGENCE, OR STRICT LIABILITY.

In no event shall the responsibility of OMRON for any act exceed the individual price of the product on which liability is asserted.

IN NO EVENT SHALL OMRON BE RESPONSIBLE FOR WARRANTY, REPAIR, OR OTHER CLAIMS REGARDING THE PRODUCTS UNLESS OMRON'S ANALYSIS CONFIRMS THAT THE PRODUCTS WERE PROPERLY HANDLED, STORED, INSTALLED, AND MAINTAINED AND NOT SUBJECT TO CONTAMINATION, ABUSE, MISUSE, OR INAPPROPRIATE MODIFICATION OR REPAIR.

## Application Considerations

### SUITABILITY FOR USE

OMRON shall not be responsible for conformity with any standards, codes, or regulations that apply to the combination of products in the customer's application or use of the products.

Take all necessary steps to determine the suitability of the product for the systems, machines, and equipment with which it will be used.

Know and observe all prohibitions of use applicable to this product.

NEVER USE THE PRODUCTS FOR AN APPLICATION INVOLVING SERIOUS RISK TO LIFE OR PROPERTY WITHOUT ENSURING THAT THE SYSTEM AS A WHOLE HAS BEEN DESIGNED TO ADDRESS THE RISKS, AND THAT THE OMRON PRODUCTS ARE PROPERLY RATED AND INSTALLED FOR THE INTENDED USE WITHIN THE OVERALL EQUIPMENT OR SYSTEM.

## Disclaimers

### PERFORMANCE DATA

Performance data given in this catalog is provided as a guide for the user in determining suitability and does not constitute a warranty. It may represent the result of OMRON's test conditions, and the users must correlate it to actual application requirements. Actual performance is subject to the OMRON *Warranty and Limitations of Liability*.

### CHANGE IN SPECIFICATIONS

Product specifications and accessories may be changed at any time based on improvements and other reasons. Consult with your OMRON representative at any time to confirm actual specifications of purchased product.

### DIMENSIONS AND WEIGHTS

Dimensions and weights are nominal and are not to be used for manufacturing purposes, even when tolerances are shown.

**ALL DIMENSIONS SHOWN ARE IN MILLIMETERS.**

To convert millimeters into inches, multiply by 0.03937. To convert grams into ounces, multiply by 0.03527.

Cat. No. N141-E1-01 **In the interest of product improvement, specifications are subject to change without notice.**

## OMRON Corporation

Industrial Automation Company

Industrial Devices and Components Division H.Q.

Industrial Control Components Department

Shiokoji Horikawa, Shimogyo-ku,

Kyoto, 600-8530 Japan

Tel: (81)75-344-7119/Fax: (81)75-344-7149

Printed in Japan

0305-1.5M (0305) (O)