

Accurate Detection of Heater Element Burnout Regardless of Heater Capacities

- Accurately detects a burned heater element or elements incorporated by a molding machine or packing machine and outputs an alarm signal.
- Precisely singles out the burned element even if one heater element among several heater elements has been burned out.
- Applicable to small- to large-capacity heater elements.
- All K2CU-F large-capacity, built-in current transformer models work with both single-phase and three-phase heaters.
- Voltage fluctuation compensation function eliminates false alarms due to variations in the supply voltage.

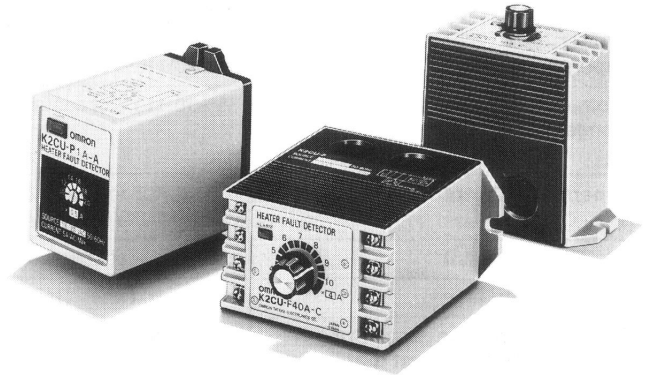

Ordering Information

K2CU-F□□A-□GS Model with Gate Input Terminals

Control supply voltage		Operating current			
		4 to 10 A	8 to 20 A	16 to 40 A	32 to 80 A
100 VAC	With voltage fluctuation compensation	K2CU-F10A-CGS	K2CU-F20A-CGS	K2CU-F40A-CGS	K2CU-F80A-CGS
110 VAC		K2CU-F10A-DGS	K2CU-F20A-DGS	K2CU-F40A-DGS	K2CU-F80A-DGS
200 VAC		K2CU-F10A-EGS	K2CU-F20A-EGS	K2CU-F40A-EGS	K2CU-F80A-EGS
220 VAC		K2CU-F10A-FGS	K2CU-F20A-FGS	K2CU-F40A-FGS	K2CU-F80A-FGS

K2CU-F Large-capacity, Built-in Current Transformer Models

Control supply voltage		Operating current			
		4 to 10 A	8 to 20 A	16 to 40 A	32 to 80 A
100 VAC	With voltage fluctuation compensation	K2CU-F10A-C	K2CU-F20A-C	K2CU-F40A-C	K2CU-F80A-C
110 VAC		K2CU-F10A-D	K2CU-F20A-D	K2CU-F40A-D	K2CU-F80A-D
200 VAC		K2CU-F10A-E	K2CU-F20A-E	K2CU-F40A-E	K2CU-F80A-E
220 VAC		K2CU-F10A-F	K2CU-F20A-F	K2CU-F40A-F	K2CU-F80A-F

K2CU-P Small-capacity, Plug-in Models

Control supply voltage		Operating current			
		0.25 to 0.5 A	0.5 to 1 A	1 to 2 A	2 to 4 A
100/ 200 VAC	With voltage fluctuation compensation	K2CU-P0.5A-A	K2CU-P1A-A	K2CU-P2A-A	K2CU-P4A-A
	Without voltage fluctuation compensation	---	K2CU-P1-A	K2CU-P2-A	K2CU-P4-A
110/ 220 VAC	With voltage fluctuation compensation	K2CU-P0.5A-B	K2CU-P1A-B	K2CU-P2A-B	K2CU-P4A-B
	Without voltage fluctuation compensation	---	K2CU-P1-B	K2CU-P2-B	K2CU-P4-B

Specifications

■ Ratings

Item	K2CU-F	K2CU-P
Control supply voltage	100, 110, 200, 220 VAC	100/200, 110/220 VAC
Rated frequency	50/60 Hz	
Carry current	1.25 times as large as each model's maximum operating current	2.5 A for K2CU-P0.5A-A/-B; 5 A
Operating voltage range	85% to 110% of control supply voltage	
Voltage fluctuation compensation range	85% to 110% of control supply voltage	85% to 110% of control supply voltage (applicable only on models with voltage fluctuation compensation)
Operating current	4 to 10 A, 8 to 20 A, 16 to 40 A, 32 to 80 A (continuously variable)	0.25 to 0.5 A, 0.5 to 1 A, 1 to 2 A, 2 to 4 A (continuously variable)
Releasing current	105% max. of operating current	110% max. of operating current
Operate time	0.5 s max. (when current changes from 150% to 0%)	
Gate input voltage range (for models with gate input terminals)	5 to 30 VDC	---
Control output	2 A at 220 VAC, SPDT ($\cos\phi = 0.4$)	
Power consumption	Input: 0.5 VA max. Power supply: 5 VA max.	Input: 1 VA max. Power supply: 4 VA max.

■ Characteristics

Setting accuracy	±7% max.
Repeat accuracy	±3% max.
Influence of temperature	±10% max. (at 20°C±30°C)
Influence of voltage	Models without voltage fluctuation compensation: ±3% max. of the value measured at the control supply voltage, on condition that the voltage fluctuation is 85% to 110% of the control supply voltage Models with voltage fluctuation compensation: ±5% max. of the logical value, on condition that the voltage fluctuation is 85% to 110% of the control supply voltage. (see note)
Influence of frequency	±3% max. (at ±5% of rated frequency)
Insulation resistance	10 MΩ min. (at 500 VDC) between electric circuits and mounting panel
Dielectric strength	2,000 VAC, 50/60 Hz for 1 min between electric circuits and mounting panel
Overcurrent	20 times of max. set value of operating current for 2 s
Vibration resistance	Destruction: 16.7 Hz, 1-mm double amplitude for 10 min each in X, Y, and Z directions
Shock resistance	Destruction: 100 m/s ² (approx. 10G)
Ambient temperature	Operating: -10°C to 55°C (with no icing)
Ambient humidity	Operating: 45% to 85%
Weight	K2CU-F: approx. 390 g; K2CU-P: approx. 300 g

Note: The logical value is an operating value within a range of 0.85 to 1.1 with a voltage fluctuation of 85% to 110%, based on the value at the control supply voltage measured as 1.

Operation

K2CU-F A- GS Series

When power is supplied to the heater (when the SSR is ON), a current flows through the wires to the heater elements. At the same time, a voltage is imposed on the gate circuit and the K2CU-F□□A□GS begins monitoring the current flowing through the heater wires.

The current flowing to the heater wires is detected by the detector sections through each Current Transformer (CT) incorporated by the K2CU-F□□A□GS.

The current signals transmitted by the two CTs are sent to the current-voltage converters, smoothing circuits, and comparators as shown in the diagram.

The signal generated by the reference voltage generator is sent to the setting circuit to provide a reference value. The reference value is sent to the comparators. Each comparator compares its heater element current input and the reference value. If the input is lower than the reference value, a signal is sent to the output circuit.

There are two detector sections operating independently. If either of the input signals from the CTs is lower than the reference value, the output relay and alarm indicator will be activated.

The K2CU-F□□A□GS incorporates a voltage fluctuation compensation function which automatically corrects the reference value if the supply voltage fluctuates.

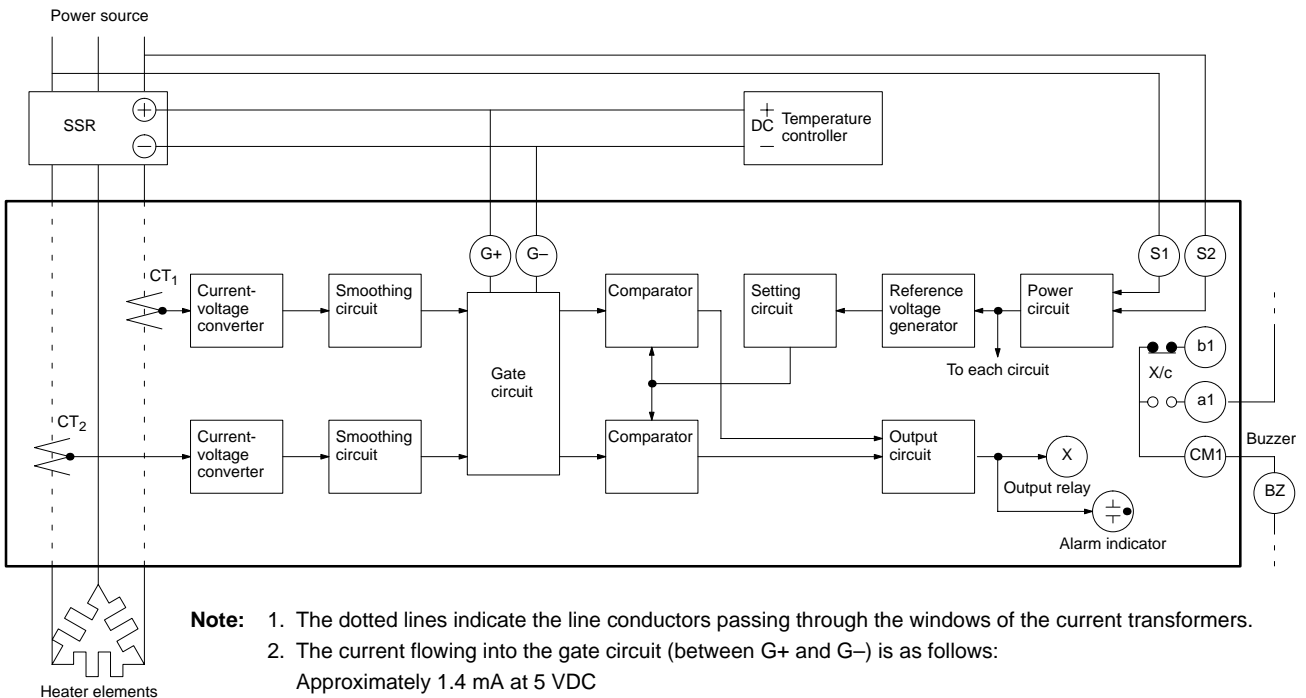

- Note:**
1. The dotted lines indicate the line conductors passing through the windows of the current transformers.
 2. The current flowing into the gate circuit (between G+ and G-) is as follows:
 Approximately 1.4 mA at 5 VDC
 Approximately 3.4 mA at 12 VDC
 Approximately 6.7 mA at 24 VDC
 3. When using a K2CU which has the model number suffix "GS" (a model that incorporates gate input terminals), the control output of the temperature controller must be a voltage output type.

K2CU-F Series

When power is supplied to the heater (when the contactor is ON), a current flows through the wires to the heater elements. At the same time, a voltage is imposed on the power circuit of the K2CU-F.

The current flowing to the heater wires is detected by the detector sections through each Current Transformer (CT) incorporated by the K2CU-F.

The current signals transmitted by the two CTs are sent to the current-voltage converters, smoothing circuits, and comparators as shown in the diagram.

The signal generated by the reference voltage generator is sent to the setting circuit to provide a reference value. The reference value is sent to the comparators. Each comparator compares its heater element current input and the reference value. If the input is lower than the reference value, a signal is sent to the output circuit.

There are two detector sections operating independently. If either of the input signals from the CTs is lower than the reference value, the output relay and alarm indicator will be activated.

The K2CU-F incorporates a voltage fluctuation compensation function which automatically corrects the reference value if the supply voltage fluctuates.

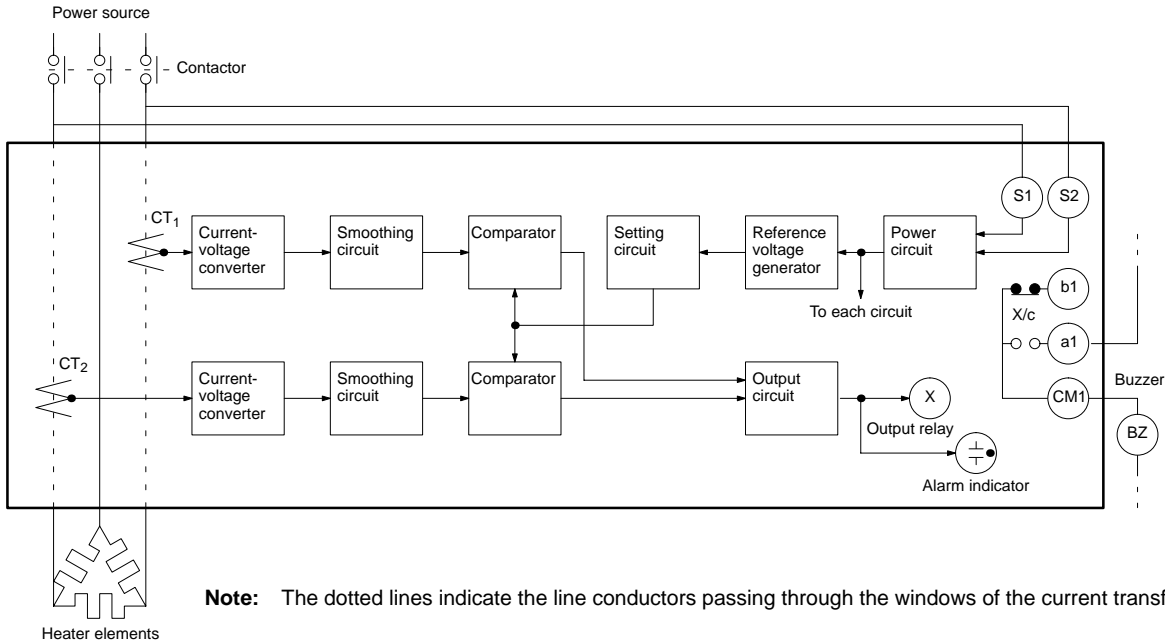

Note: The dotted lines indicate the line conductors passing through the windows of the current transformers.

K2CU-P Series

The K2CU-P operates basically in the same way as the K2CU-F.

The comparator compares external current signals and the reference value and outputs the result of the comparison to the output circuit.

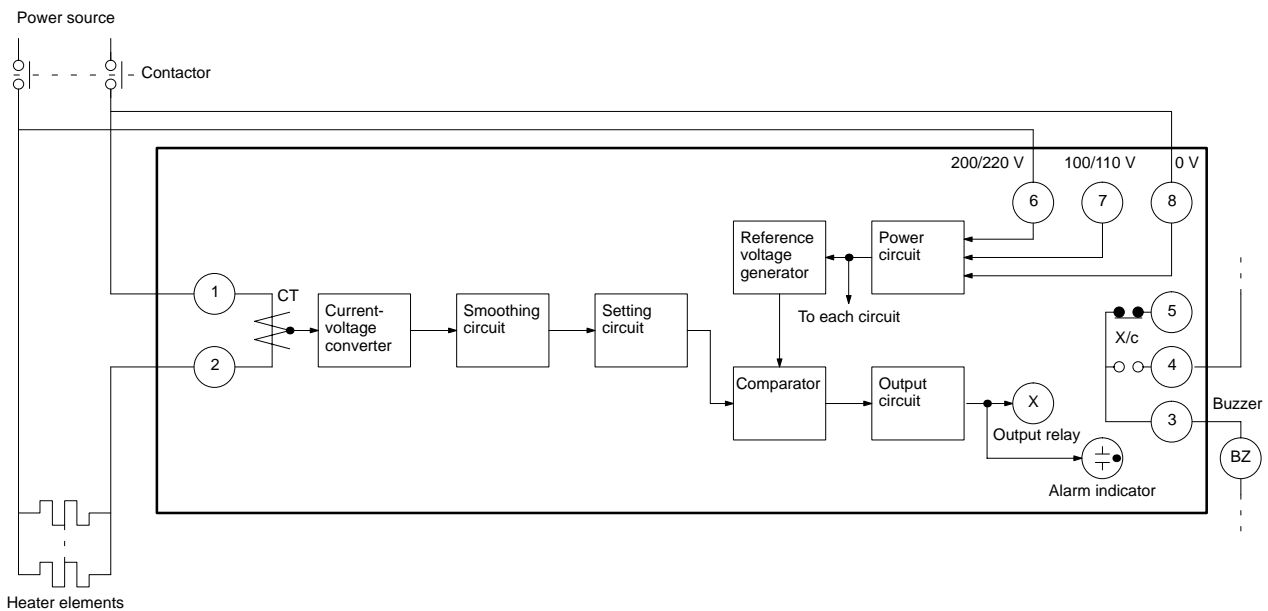

Setting of Operating Current

Use the potentiometer on the front panel to set the operating current.

Rotate the knob to set the desired current value at which the Heater Burnout Detector should operate. Do not exceed the maximum and minimum positions.

The K2CU-F's scale is divided into 12 graduations including sub-graduations and the K2CU-P's scale is divided into 5 graduations.

The knobs of the K2CU-F and K2CU-P as shown in the illustrations are set to 32 A and 0.7 A respectively.

The set operating current is defined as the mean value of the heater current under normal operating conditions and the heater current under a burnout or abnormal condition.

$$\text{Set value} = \frac{\text{Normal current} + \text{abnormal current}}{2}$$

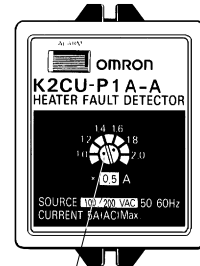
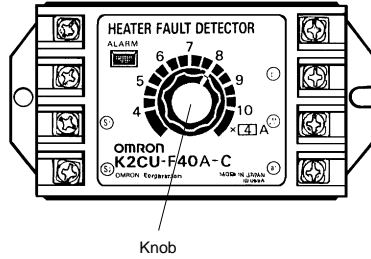

Heater Connection and Current

The following table shows the different connections possible. The formula under each illustration indicates the electrical current value of the heater elements under normal and abnormal conditions.

Phase		Normal condition	Abnormal condition	
Single phase				
Three phase	Delta network			
	Star network			
	V network			

Note: Values in this table are correct when a 200 VAC, 1 kW heater is used on a single-phase or three-phase current.

■ Operation Check

K2CU-F A- GS

The operation of the heater burnout detector can be easily checked as follows:

In a Single-phase Circuit

Set the operating current to be 0.6 to 0.55 times the heater current. Close the SW₂ with switch SW₁ turned on. Confirm that the alarm indicator remains off.

Turn off SW₁ and confirm that the alarm indicator comes on, and that the output relay operates.

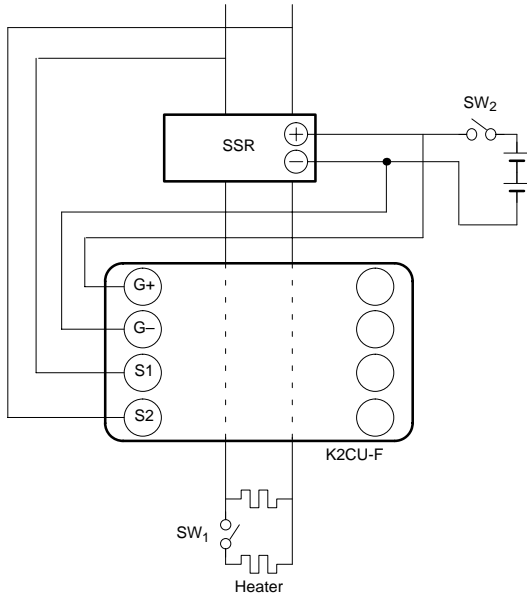

In a Three-phase, Star Network

Set the operating current to be 0.9 times the heater current.

Close the SW₂ with switch SW₁ turned on. Confirm that the alarm indicator remains off.

Turn off SW₁ and confirm that the alarm indicator comes on, and that the output relay operates.

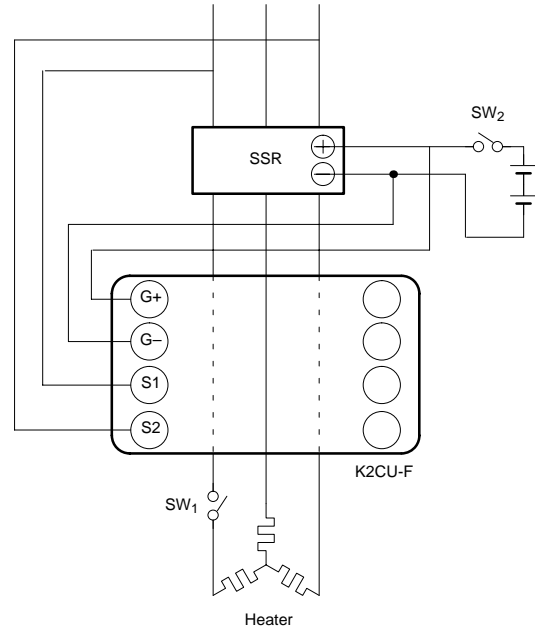

In a Three-phase, Delta Network

Set the operating current to be 0.6 times the heater current.

Close the SW₃ with switches SW₁ and SW₂ turned on. Confirm that the alarm indicator remains off.

Turn off SW₂ and confirm that the alarm indicator comes on, and that the output relay operates.

Turn on SW₁ set the operating current to be 0.9 times the heater current, and confirm that the alarm indicator goes off and the output relay releases.

Turn off SW₁ and confirm that the alarm indicator comes on, and that the output relay operates.

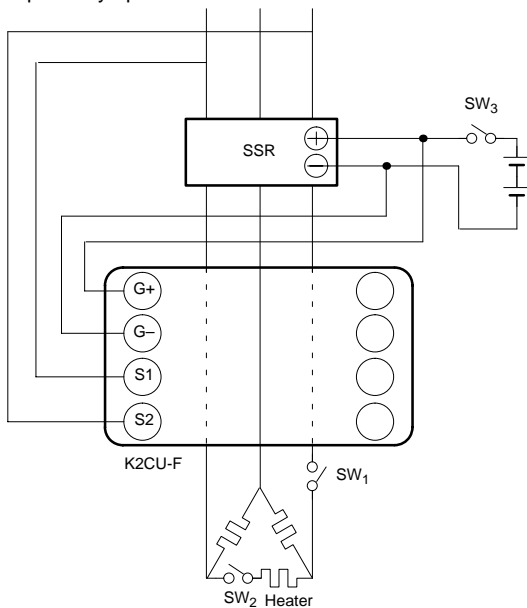

In a Three-phase, V Network 1

Set the operating current to be 0.3 to 0.35 times the heater current.
 Close the SW₂ with switch SW₁ turned on. Confirm that the alarm indicator remains off.
 Turn off SW₁ and confirm that the alarm indicator comes on, and that the output relay operates.

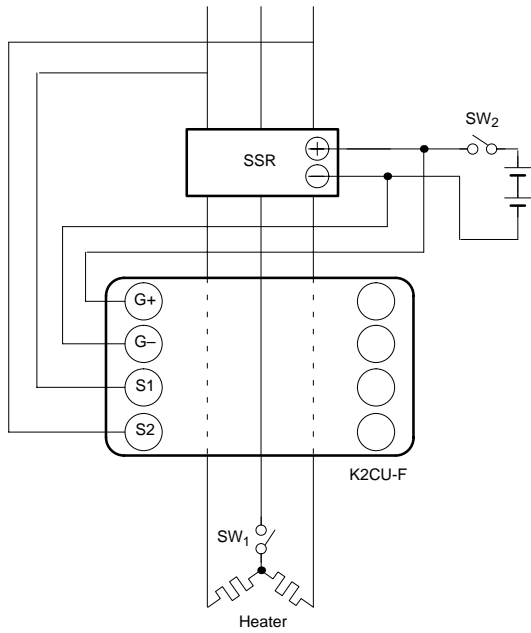

In a Three-phase, V Network 2

Set the operating current to be 0.6 times the heater current (of the phase connected between terminals 1 and 2, or the one passed through the window of the window-type Current Transformer of the heater burnout detector).
 Close the SW₂ with switch SW₁ turned on. Confirm that the alarm indicator remains off.
 Turn off SW₁ and confirm that the alarm indicator comes on, and that the output relay operates.

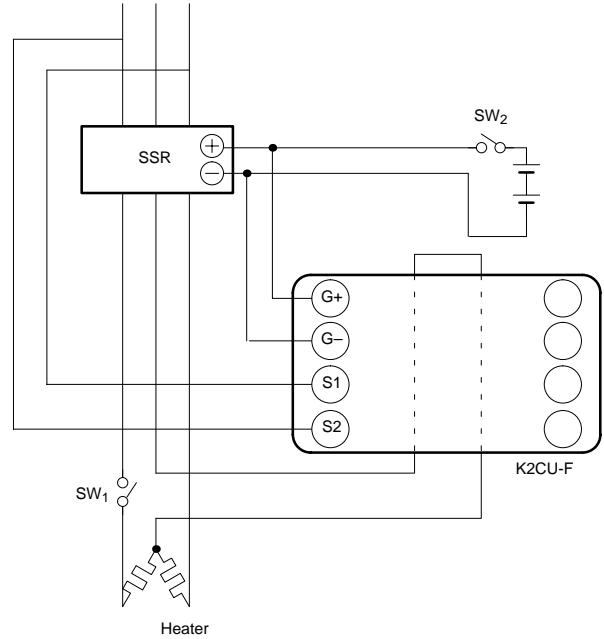

K2CU-F, K2CU-P

The operation of the heater burnout detector can be easily checked as follows:

In a Single-phase Circuit

Set the operating current to be 0.55 to 0.6 times the heater current.

Close the contactor with switch SW₁ turned on. Confirm that the alarm indicator remains off.
 Turn off SW₁ and confirm that the alarm indicator comes on, and that the output relay operates.

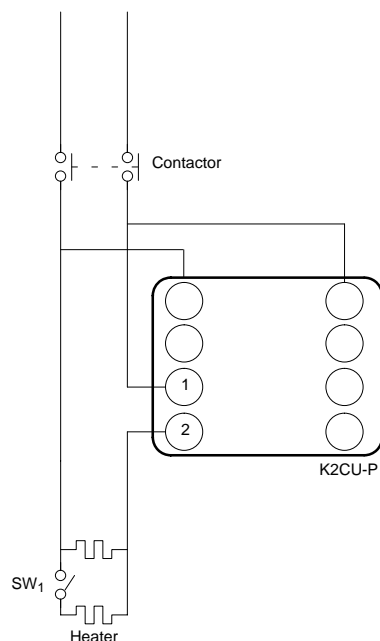
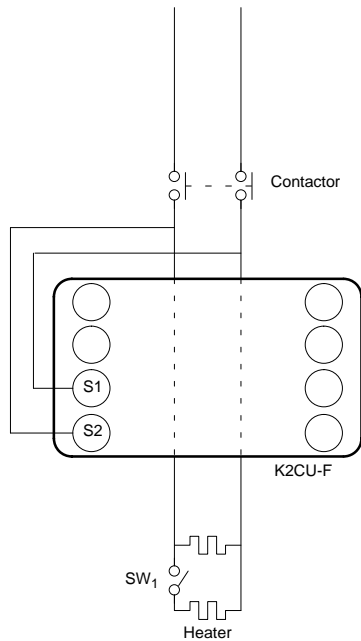

In a Three-phase, Delta Network

Set the operating current to be 0.6 times the heater current.
 Close the contactor with switches SW₁ and SW₂ turned on. Confirm that the alarm indicator remains off.
 Turn off SW₂ and confirm that the alarm indicator comes on, and that the output relay operates.
 Turn on SW₁ set the operating current to be 0.9 times the heater current, and confirm that the alarm indicator goes off and the output relay releases.
 Turn off SW₁ and confirm that the alarm indicator comes on, and that the output relay operates.

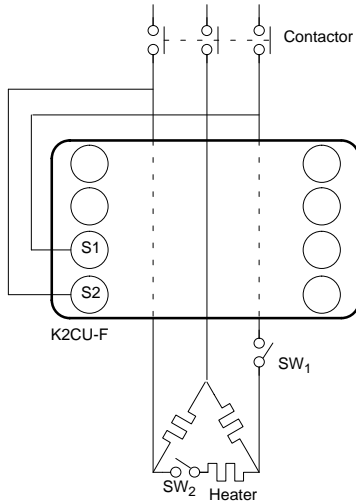

In a Three-phase, Star Network

Set the operating current to be 0.9 times the heater current.
 Close the contactor with switch SW₁ turned on. Confirm that the alarm indicator remains off.
 Turn off SW₁ and confirm that the alarm indicator comes on, and that the output relay operates.

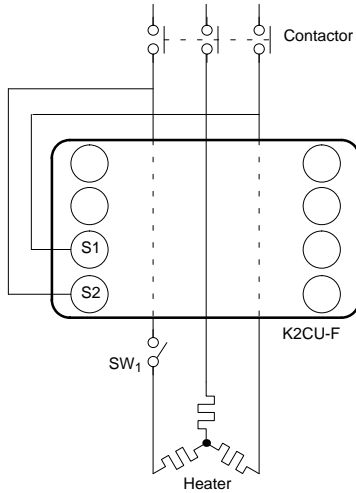

In a Three-phase, V Network 1

Set the operating current to be 0.3 to 0.35 times the heater current.
 Close the contactor with switch SW₁ turned on. Confirm that the alarm indicator remains off.
 Turn off SW₁ and confirm that the alarm indicator comes on, and that the output relay operates.

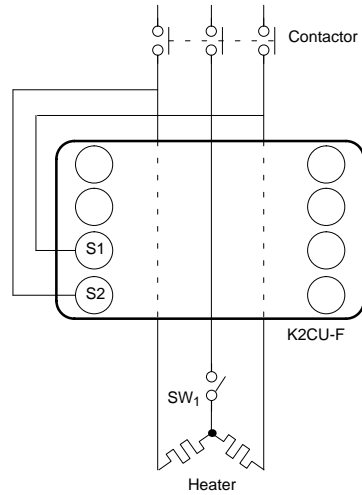

In a Three-phase, V Network 2

Set the operating current to be 0.6 times the heater current (of the phase connected between terminals 1 and 2, or the one passed through the window of the window-type Current Transformer of the heater burnout detector).
 Close the contactor with switch SW₁ turned on. Confirm that the alarm indicator remains off.
 Turn off SW₁ and confirm that the alarm indicator comes on, and that the output relay operates.

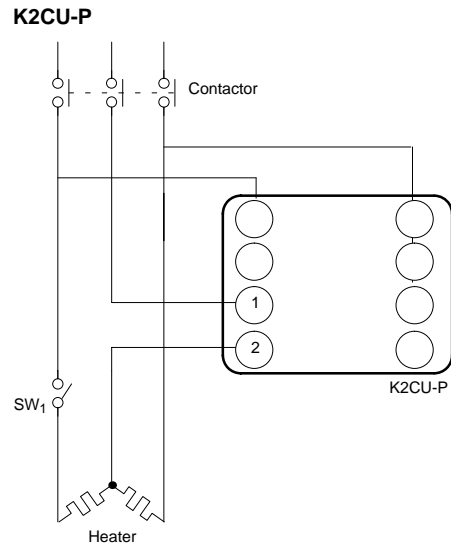

K2CU-F

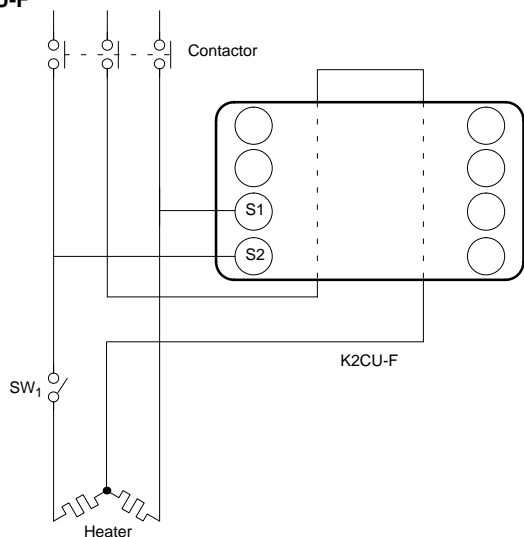

■ Test Circuit

To check the operation in detail, use the following circuit.

K2CU-F

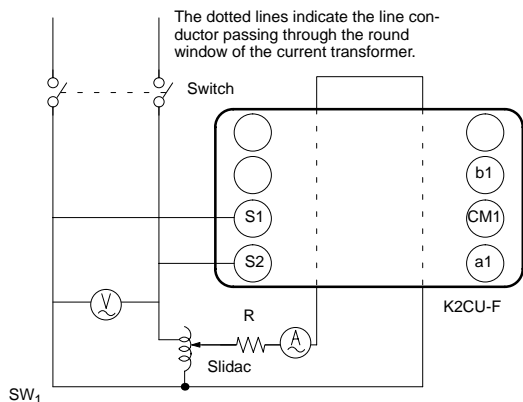

K2CU-P

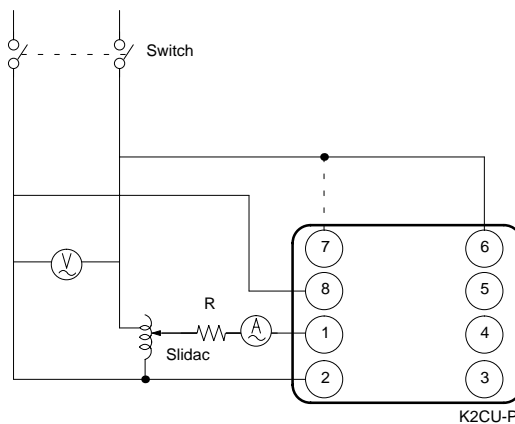

Note: Determine the value of R according to the specifications of the K2CU to be used. The dotted line indicates the connection at a supply voltage of 100 or 110 VAC.

Dimensions

Note: All units are in millimeters unless otherwise indicated.

K2CU-P

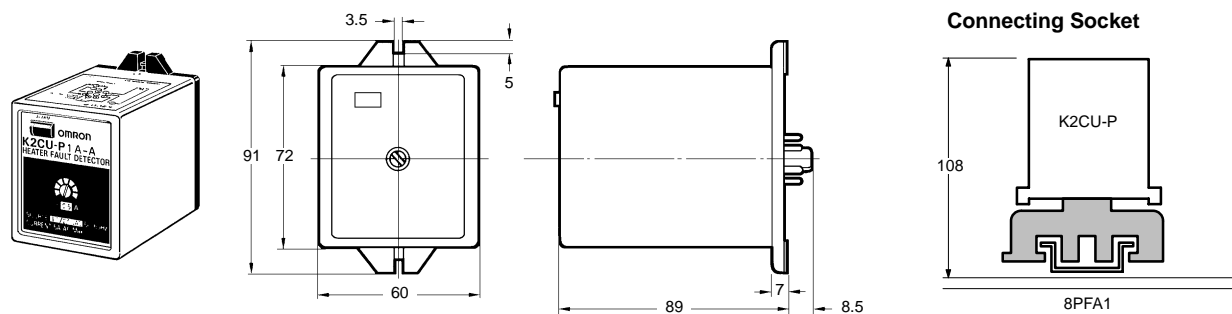

K2CU-F

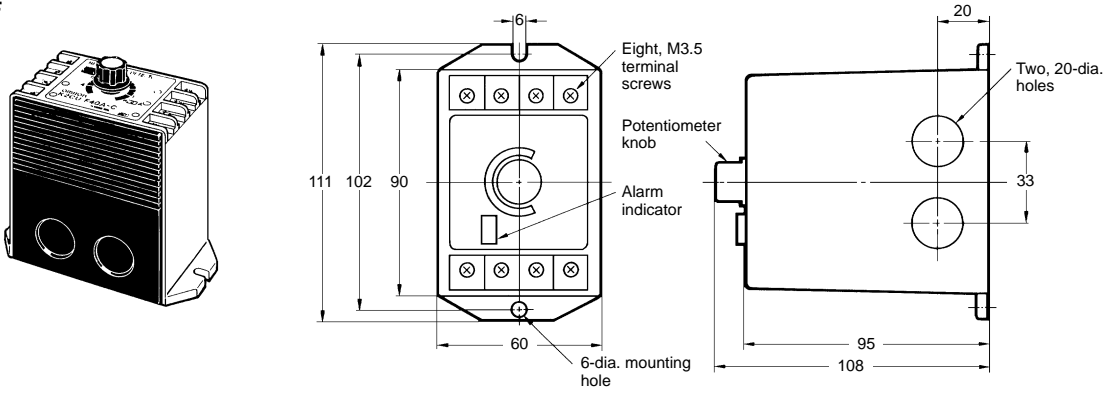

Mounting Holes

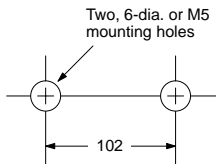

- Note:**
1. Install the K2CU-F on a flat surface.
 2. When solderless terminal lugs are desired, use ones having an outer diameter of 6.5 mm maximum.

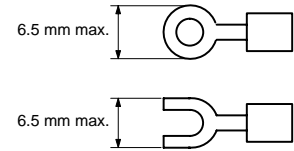

Installation

External Connections
K2CU-F A- GS

Single-phase Heater

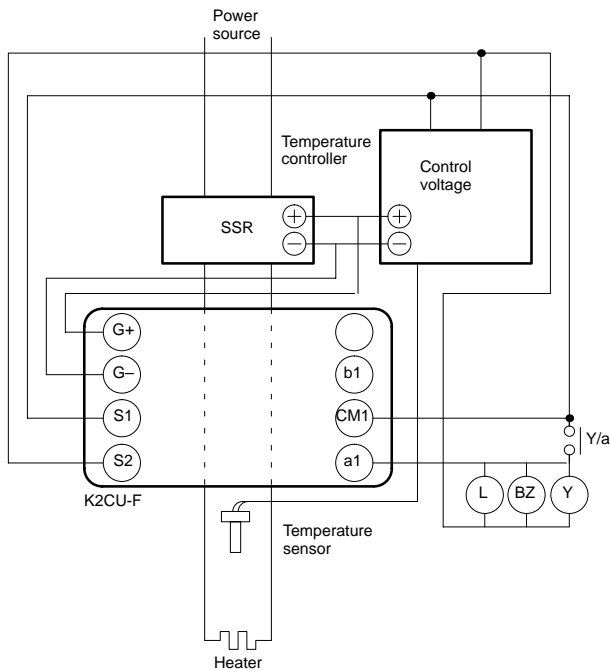

Three-phase Heater

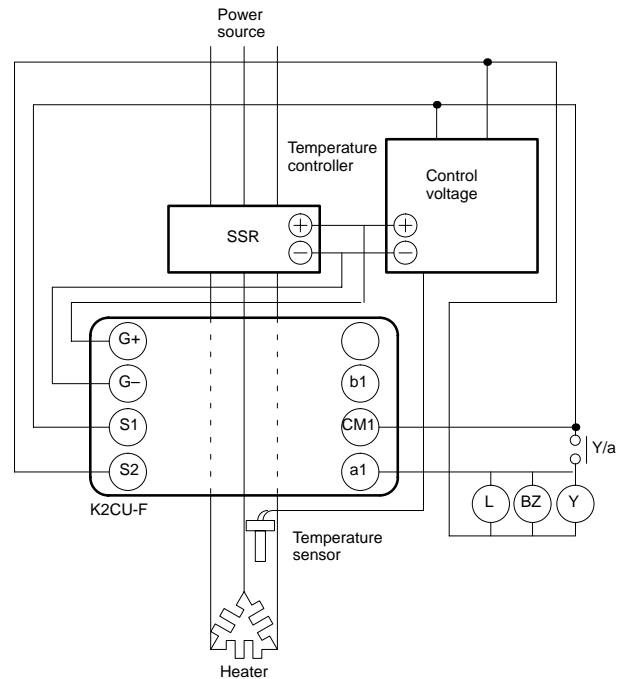

K2CU-F

Single-phase Heater

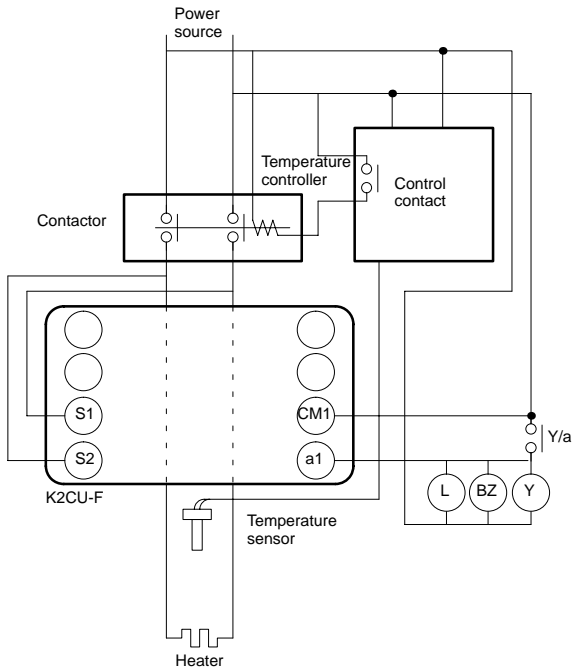

Three-phase Heater

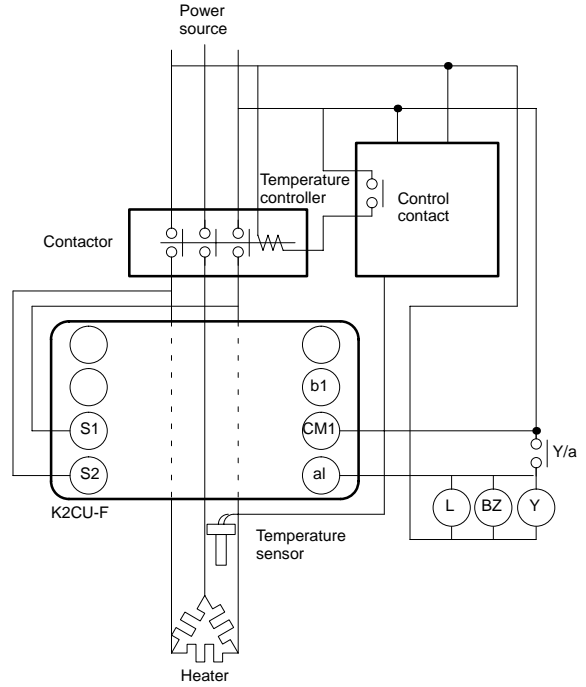

Three-phase, V-connected Heater

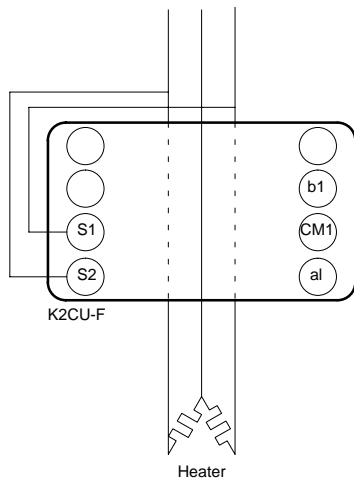

With External Current Transformer

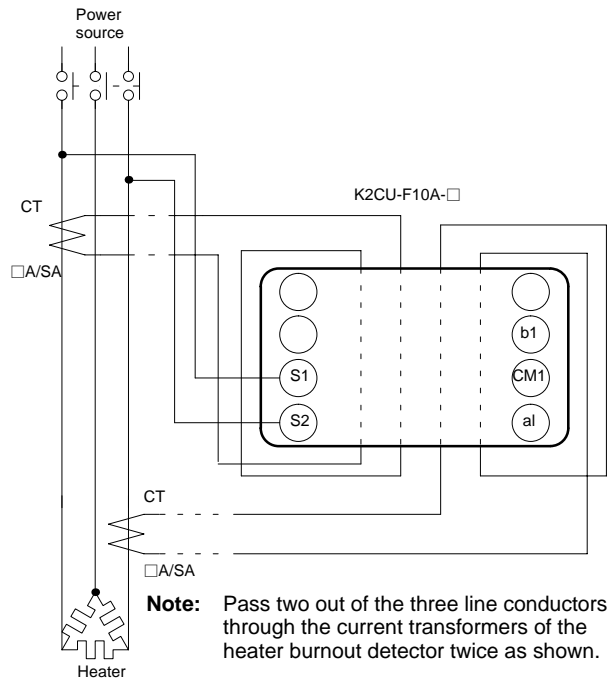

K2CU-P Small-capacity, Plug-in Models

Small-capacity Heater

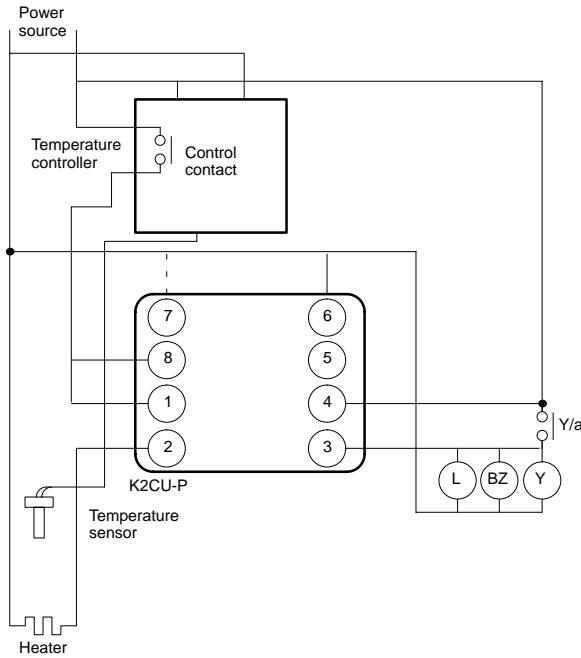

With External Current Transformer

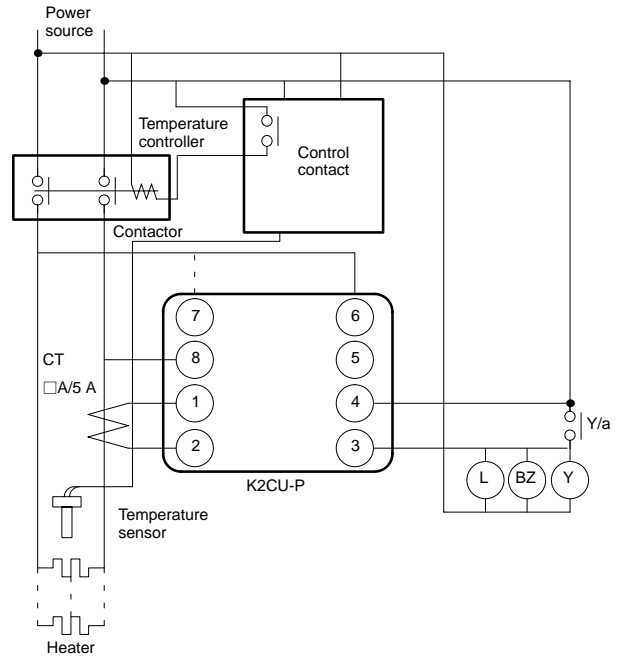

- Note:**
1. The dotted lines which pass through the heater burnout detector indicate the line conductor passing through the round "window" of the window-type Current Transformer.
 2. Y: External relay for self-holding circuit
BZ: Alarm buzzer
L: Alarm indicator
 3. To use an 100 (110) VAC control power supply with K2CU-P, connect it to terminal 7 instead of 6.

Precautions

K2CU-F A- GS

Use the K2CU-F□□A-□GS (with gate input terminals) in combination with a temperature controller that has PID with feed-forward circuitry to control the heater temperature, in which case, the heater element(s) must be turned ON or OFF for 0.1 s or longer.

K2CU-F

When a single-phase heater is used, pass the two lines through the openings of the heater burnout detector. When a three-phase heater is used, pass two (phases) of the three lines through the openings. In either case, if only one line passes through, an alarm signal will always be produced.

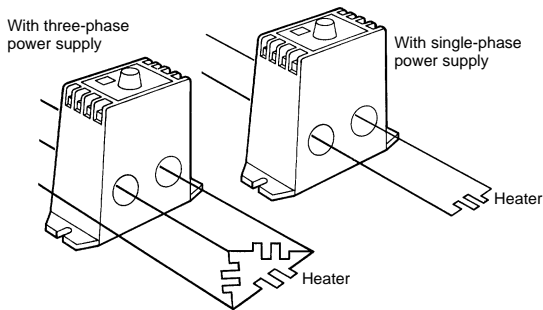

Pass the lines through the openings only once. If they are passed more than once, the actual operating current will be less than the set current. The lines can be passed in either direction.

To use the heater burnout detector at a current less than the current range that can be set, the lines must be passed more than once. Determine the number of times the lines should be passed by the following equation:

$$(\text{Operating current}) \times n = \text{Current setting range}$$

where,

n: number of times the lines loop through the window

All K2CU-F models incorporate a voltage fluctuation compensation function.

K2CU-P

The K2CU-P can be used only in single-phase circuits.

Do not pull out the K2CU-P from the socket when the K2CU-P is energized. Especially when using it in combination with a Current Transformer commercially available, this practice causes the secondary circuit of the transformer to open, which is very dangerous.

General

Refer to "External Connections" before using the K2CU with external CTs.

When a temperature controller is used in combination with the K2CU (except for the K2CU-F□□A-□GS), the heater element(s) must be turned ON or OFF for 1 s or longer (although the heater element(s) can be turned ON for 0.5 s according to the specifications).

The K2CU cannot be used with a phase-control circuit, inverter circuit, frequency-count circuit, cycle-control unit, or a motor load.

Mounting

Securely mount the K2CU as horizontally as possible although there is no particular limitation of mounting directions.

Connection

Solderless-type terminal must be connected to the terminals securely.

Wire the terminals correctly by referring to the external connections. The terminals have no polarity. Be sure to connect 100 (or 110) V to the 100-V (or 110-V) terminals and 200 (or 220) V to the 200-V (or 220-V) terminals of the K2CU-P or the K2CU-P may malfunction.

The control power source for the K2CU (except for the K2CU-F□□A-□GS) must be supplied from the load side via a contactor.

Be sure to impose a voltage between the 0-V terminal and 100-V (or 110-V) terminal or the 0-V terminal and 200-V (or 220-V) terminal of the K2CU-P, otherwise the K2CU-P will not operate.

Operating Current Setting when Several Heaters are Used

The following table shows relative values of changes in the current when any one of several heaters connected in parallel has burned out. The current value under normal condition is 1. Use this table as a guideline in determining the operating current.

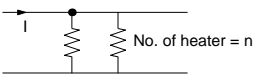
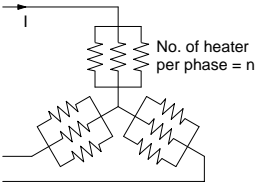
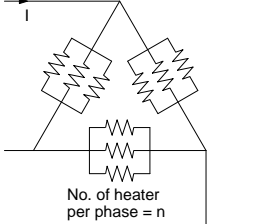
Connection		n = 1	n = 2	n = 3	n = 4	n = 5
 No. of heater = n		0	0.5	0.67	0.75	0.8
 No. of heater per phase = n	Current in burned-out phase	0	0.6	0.75	0.82	0.86
	Current in other phases	0.87	0.92	0.95	0.96	0.97
 No. of heater per phase = n	Current in burned-out phase	0.58	0.77	0.84	0.88	0.91
	Current in other phases	1	1	1	1	1

- Note:**
1. This table shows the respective change rates in current when any one of several heaters connected in parallel has burned out.
 2. The current value under the normal condition is 1.
 3. The values in this table are logical values. Actually, these values may vary slightly because of influence of unbalanced loads (heaters). It is therefore recommended to test the actual current values and the load condition before determining the operating current, especially when the current under the normal condition and that under an abnormal condition do not significantly differ.

ALL DIMENSIONS SHOWN ARE IN MILLIMETERS.

To convert millimeters into inches, multiply by 0.03937. To convert grams into ounces, multiply by 0.03527.

Cat. No. N39-E1-2 **In the interest of product improvement, specifications are subject to change without notice.**

OMRON Corporation

Measuring & Supervisory Controls Division
29th Fl., Crystal Tower Bldg.
1-2-27, Shiromi, Chuo-ku,
Osaka 540 Japan
Phone: 06-949-6014 Fax: 06-949-6028

Printed in Japan
0393-1M (0393)