



# **SYSDRIVE 3G3FV Series**

**General-purpose Inverter with Advanced Features**

**Highly Functional, Easy-to-use Inverter**

**Vector Control Opens a New World of Applications**

**Additional Optional Card Allows CompoBus/D (DeviceNet) Communications**

# Total Harmony between Intelligence, Performance, and Simplicity

The SYSDRIVE 3G3FV is OMRON's new special-purpose inverter. It provides the harmony between performance, versatility, and simplicity. Using a unique vector control it can deliver up to 150% torque from a standstill in closed loop and no less than 100% torque at 1 Hz in open loop. The plain-text LCD, clever menu structure, and built-in auto-tuning function ensure a user-friendliness that is second-to-none.

## ■ Easy-to-use Conversational-type Digital Operator

The Digital Operator incorporates an easy-to-see, easy-to-use, two-line LCD that displays parameter names and settings with 16 characters per line. Seven languages are available for displaying messages.

## ■ Functionality that Puts You in Full Control

Four control modes: V/f, V/f with PG, sensorless flux vector, full flux vector. Also included are the following functions:

- PID control
- Droop control
- Torque limit
- Position lock (zero-servo)
- Built-in RS-232C port with open protocol

Simple parameter settings make it possible to use the 3G3FV like a servo drive or simple multi-mode drive in a wide range of applications.

## ■ True Flux Vector Control Allows DC Performance or Higher with a Standard AC Motor

DC-like performance or even better can now be achieved out of a standard induction motor. Thanks to the incorporation of a true flux vector algorithm in the 3G3FV, up to 150% torque can be achieved at 0 Hz thus allowing top performance in difficult applications such as elevators, extruders, and cranes. The 3G3FV also has a built-in torque limit function. Where an encoder is not permitted, and yet a high starting torque is required, open flux vector can be used.

The 3G3FV has  $\pm 0.2\%$  speed control accuracy without the PG and  $\pm 0.02\%$  speed control accuracy with the PG and ensures high-precision performance without being influenced by load changes.

### Torque and Frequency Characteristics (in Vector Control without PG)

- Starts Easily Even from 1/100 Low Speed

- Highly Precise Control at Low and High Speeds

Torque (%)

Torque (%)

Operating frequency (Hz)

Operating frequency (Hz)

The 3G3FV can generate high starting torque from 1/100 low speed without the PG and 150% or more torque at 0 Hz with the PG.

High-precision performance is provided with light or heavy loads and the high performance isn't influenced by load changes.

## Caution

This catalog contains only the information required for selecting Inverter models, and not for actually operating them. Be sure to carefully read the relevant operation manuals before attempting to operate any of the equipment described here.

## Table of Contents

Features .....
Applications .....
Digital Operator .....
Specifications .....
Terminal Block .....
Dimensions .....
Wiring .....
Options .....
Standard Models .....

### ■ Built-in Auto-tuning Function

The unique auto-tuning function of the 3G3FV solves classical problems, such as the limitation of motor types and difficulty in setting motor constants.

The motor constant is set automatically just by entering the motor's rating plate value. This feature allows flux vector control to operate accurately with virtually any normal AC induction motor regardless of the supplier.

### ■ Versatile Optional Cards

Versatile Optional Cards are available for a wide variety of systems.

- High-precision speed feedback operation:  
PG Speed Control Card
- Speed settings from external devices:  
Analog Reference and Digital Reference Cards
- Remote operation monitoring:  
Analog Monitor and Pulse Monitor Cards
- Applicable to open networks:  
CompoBus/D Communications Card

### ■ Versatile Functions

#### • PID Control

The 3G3FV incorporates the popular PID control function which can operate fans and pumps very efficiently.

#### • Effective Harmonic Countermeasures for Power Supply

Models of 18.5 kW and over have built-in DC reactors. DC reactors can be built into models of 15 kW or less as an option.

#### • A Complete Lineup to Choose From

200 V: 0.4 to 75 kW, 16 models

400 V: 0.4 to 300 kW, 21 models

### ■ Torque Ripple at Low Speeds Reduced

Improvements in the current detector for vector control and in the responsiveness of current control have greatly reduced torque ripple.

## A Wide Variety of Control Modes Handles Advanced Applications with Ease

### ■ General Conveyers (Conveyer Control)

- Production efficiency is improved by finding the optimum conveyer speed for particular objects.
- The soft start/stop function can be used as required to prevent damage to loads and to ensure safe operation and consistent quality.

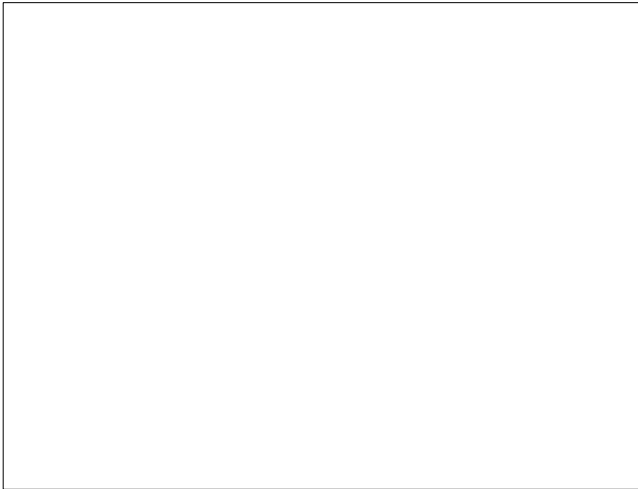

### ■ General Machinery (Machinery with Varying Loads)

- Speed/Torque control ensures the stable operation of cutting machines which have loads that can change suddenly.

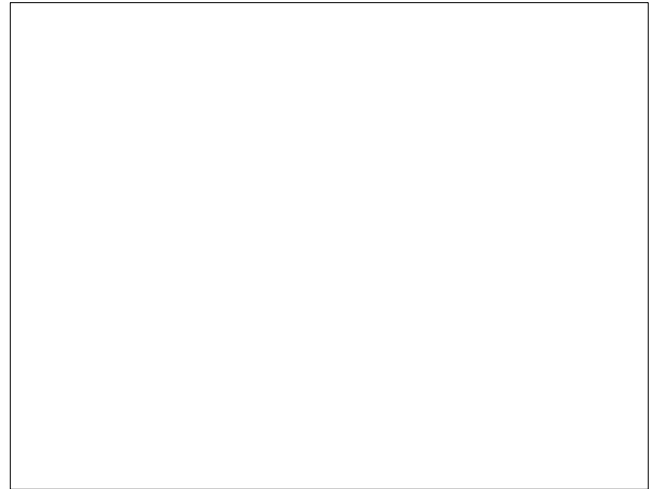

### ■ Winding Machines

- High-precision speed control and torque control ensure the efficient operation of winding machines.
- The 3G3FV improves product quality and production efficiency simultaneously.

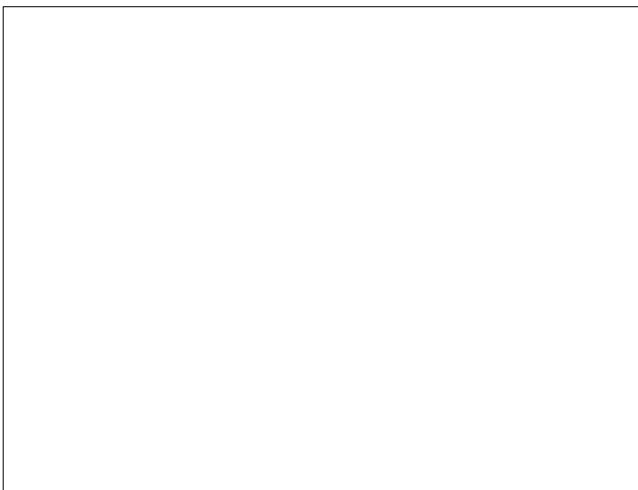

### ■ Elevators

- High starting torque shortens the positioning time of stacker cranes.
- The Pulse Generator ensures high holding capability at 0 Hz and precise positioning.

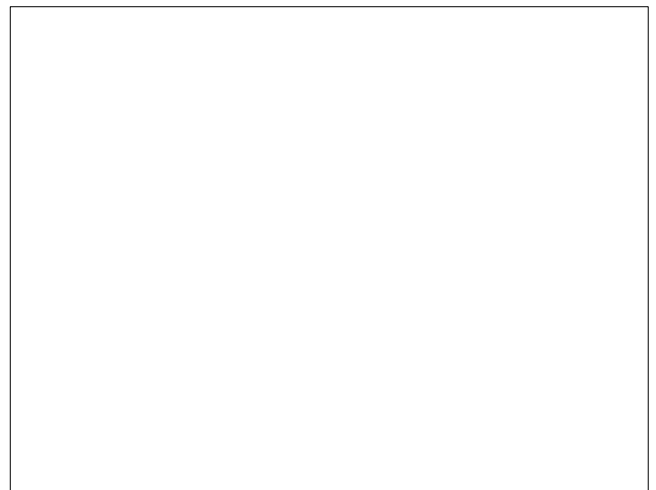

# Digital Operator

## ■ Nomenclature and Functions

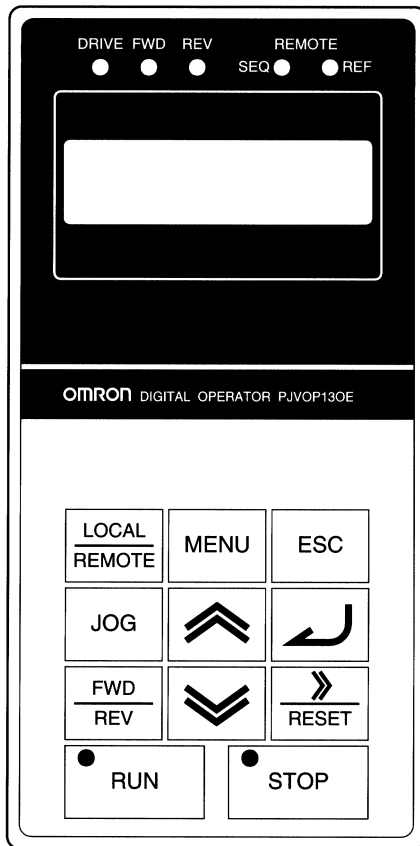

### Operation Mode Indicators

**DRIVE:** Lit when in operation mode.  
**FWD:** Lit when there is a forward command input.  
**REV:** Lit when there is a reverse command input.  
**SEQ:** Lit when the forward/reverse command from the control circuit terminal is enabled.  
**REF:** Lit when the frequency reference from control circuit terminals 13 and 14 is enabled.

### Data Display

Two-line LCD that displays data for monitoring, parameter names, and set values with 16 characters per line.

### Keys

Execute operations such as setting parameters, monitoring, JOG, and auto-tuning.

## ■ Key Names and Functions

Key	Name	Function
	Operation Mode Selection Key	Switches between operation and parameter setting. This key can be enabled or disabled with a parameter setting.
	Menu Key	Displays each mode.
	Escape Key	Returns to the status before the Enter Key is pressed.
	JOG Key	Enables JOG operation when the 3G3FV is in operation with the Digital Operator.
	Forward/Reverse Rotation Selection Key	Selects the rotation direction of the motor when the 3G3FV is in operation with the Digital Operator.
	RESET/Digit Selection Key	Selects digits for parameter settings. Also acts as the reset key when an error has occurred.
	Increment Key	Selects modes, groups, functions, parameter names, and set values. This key increases numbers when pressed.
	Decrement Key	Selects modes, groups, functions, parameter names, and set values. This key decreases numbers when pressed.
	Enter Key	Enters modes, functions, constants, and set values after they are set.
	Operation Key	Starts the 3G3FV when the 3G3FV is in operation with the Digital Operator.
	Stop Key	Stops the 3G3FV. This key can be enabled or disabled with a parameter setting.

# Digital Operator

## ■ Operation of Digital Operator

Operation	Key sequence	Display	Description
Power ON		Frequency Ref U1-01= 0.00 HZ	Press to display the frequency reference.
Operating condition settings		Frequency Ref U1-01= 0.00 HZ	Set this key to LOCAL. The REMOTE (SEQ and REF) indicators will be OFF.
Forward JOG rotation		Frequency Ref U1-01= 6.00 HZ	Enables forward rotation at 6 Hz while the key is pressed.
Frequency settings		Frequency Ref 000.00 HZ	Press to change data.
		Frequency Ref 015.00 HZ	Change the frequency reference set value to 15 Hz. Select the digit with the RESET/Digit Selection Key and change the value with the Increment Key or Decrement Key.
		Frequency Ref 15.00 HZ	Press to write the set value.
		Frequency Ref U1-01= 15.00 HZ	Press to finish changing the data.
		Output Freq U1-02= 0.00 HZ	Press to select the output frequency display.
Forward rotation		Output Freq U1-02= 15.00 HZ	Press to start the 3G3FV. The RUN and FWD indicators will be lit.
Reverse rotation		Output Freq U1-02=-15.00 HZ	Press to select reverse rotation. The REV indicator will be lit.
Stop		Output Freq U1-02= 0.00 HZ	Press to decelerate the 3G3FV to stop. The STOP indicator will be lit.

## ■ Monitor Display

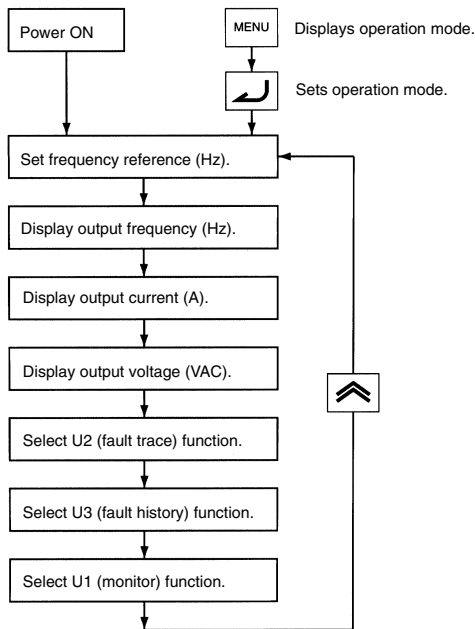

### Example of Monitor Display Items

Monitor No.	Monitor item	Monitor No.	Monitor item
U1-01	Frequency reference (Hz)	U1-08	Output power (kW)
U1-02	Output frequency (Hz)	U1-09	Torque reference (%)
U1-03	Output current (A)	U1-10	Input terminal status
U1-04	Control mode	U1-11	Output terminal status
U1-05	Motor speed (Hz)	U1-12	Operating status
U1-06	Output voltage (VAC)	U1-13	Total operating time (h)
U1-07	DC voltage (VDC)	U1-14	Software number

## ■ Auto-tuning

Operation	Key sequence	Display
Select auto-tuning function		** Main Menu ** Operation
	3 times	** Main Menu ** Auto-Tuning
Select parameter		Rated Voltage 200.0 VAC
Change data		Rated Voltage 200.0 VAC
		Rated Voltage 200.0 VAC
		Entry Accepted Rated Voltage 200.0 VAC
Select next parameter		Rated Current 1.90 A
		Rated Frequency 60.0 Hz
		Rated Speed 1750 RPM
		Number of Poles 4
		Select Motor 1/2 1
		Tuning Ready ? Press RUN key
		Tuning Ready ? Press RUN key
Start auto-tuning		Tune Proceeding □HZ □A Tune Successful
Return to operation mode		** Main Menu ** Operation

**Note:** Auto-tuning is available only when the 3G3FV is in vector control.

# Digital Operator

## Parameter Levels

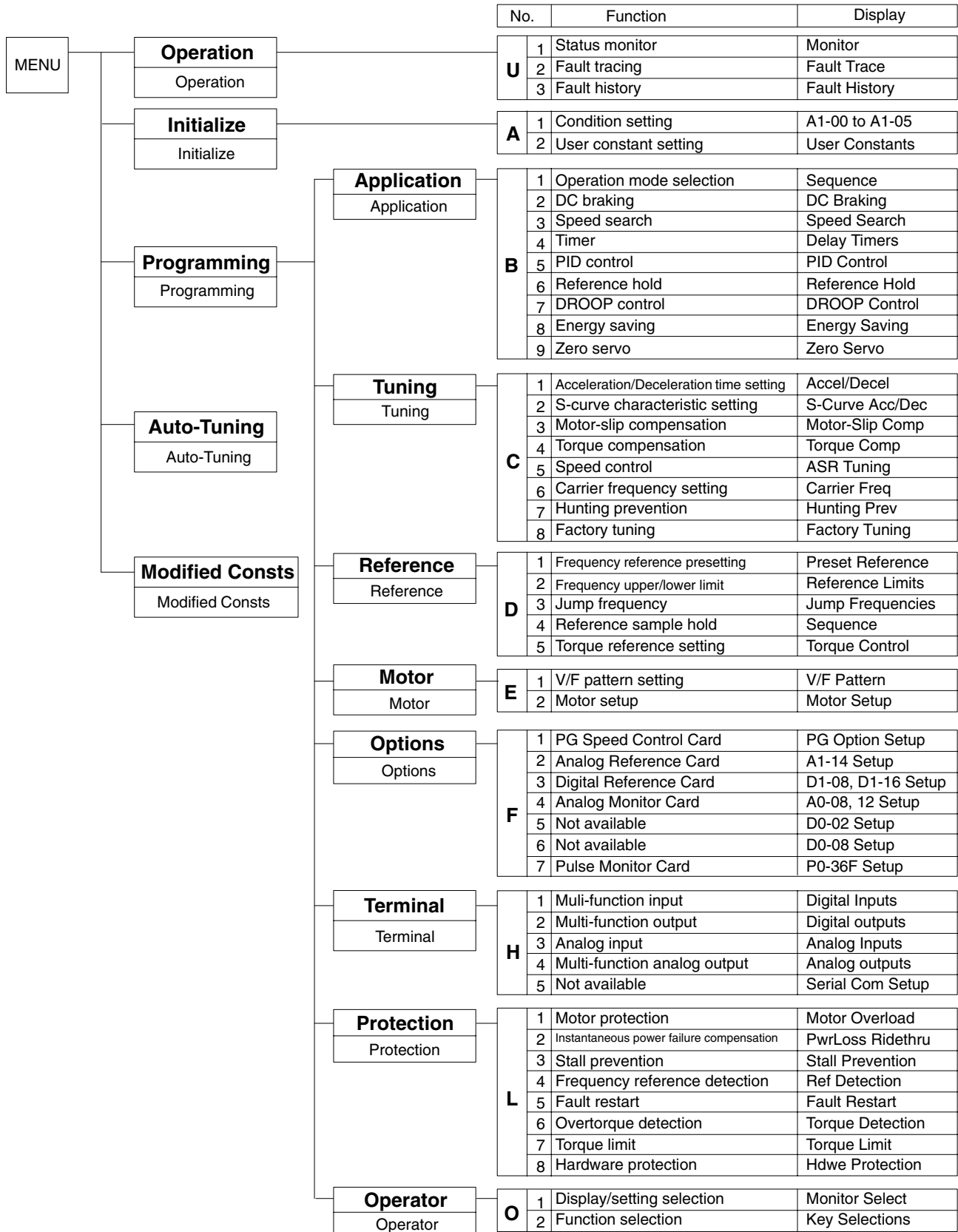

**Note:** The above parameter levels are simplified levels used mainly in programming operation.

# Specifications

## ■ Specifications

### 200-V Inverters

#### General Specifications

Model number	3G3FV-	A2004	A2007	A2015	A2022	A2037	A2055	A2075	A2110	A2150	B2185	B2220	B2300	B2370	B2450	B2550	B2750-E
Max. applicable motor capacity (kW)	0.4	0.75	1.5	2.2	3.7	5.5	7.5	11	15	18.5	22	30	37	45	55	75	
<b>Output characteristics</b>																	
Rated output capacity (kVA)	1.2	2.3	3.0	4.2	6.7	9.5	13	19	24	30	37	50	61	70	85	110	
Rated output current (A)	3.2	6.0	8.0	11	17.5	25	33	49	64	80	96	130	160	183	224	300	
Max. output voltage (V)	3-phase, 200 to 230 VAC (Corresponds to input voltage.)																
Max. output frequency (Hz)	400 Hz (Set by parameter constant.)																
<b>Power supply characteristics</b>																	
Rated voltage (V) Rated frequency (Hz)	3-phase, 200 to 230 VAC, 50/60 Hz																
Allowable voltage fluctuation	-15% to 10%																
Allowable frequency fluctuation	±5%																
Power consumption (kW)	0.07	0.09	0.12	0.14	0.22	0.30	0.35	0.59	0.73	0.89	1.2	1.4	1.8	2.1	2.7	3.3	
Approximate weight (kg)	3.0	3.0	3.0	4.5	4.5	5.5	6.0	11	11	28	28	61	62	80	80	135	

#### Control Characteristics

Model number	3G3FV-	A2004	A2007	A2015	A2022	A2037	A2055	A2075	A2110	A2150	B2185	B2220	B2300	B2370	B2450	B2550	B2750-E
Power supply harmonic countermeasures	DC reactor (option) connection possible.										DC reactor built in						
Control method	Sine wave PWM (high-carrier frequency control)																
Carrier frequency	0.4 to 15 kHz (2.0 to 15 kHz in vector control)											0.4 to 10 kHz (2.0 to 10 kHz in vector control)					
Speed control range	1:100 (1:1000 with PG)																
Speed control precision	±0.2% (±0.02% with PG)																
Speed control response	5 Hz (30 Hz with PG)																
Torque characteristics	150% at 1 Hz (150% at 0 rpm with PG). A torque limit function is incorporated.																
Torque control precision	±5% (with PG)																
Torque control response	40 Hz (with PG)																
Frequency control range	0.1 to 400 Hz																
Frequency precision (temperature characteristics)	Digital commands: ±0.01% (-10° to 40°C) Analog commands: ±0.1% (25±10°C)																
Frequency setting resolution	Digital commands: 0.01 Hz (Less than 100 Hz), 0.1 Hz (100 Hz or higher) Analog commands: 0.03 Hz/60 Hz (11 bits + sign)																
Output frequency resolution	0.01 Hz																
Overload capacity	150% of rated current for one minute																
Frequency setting signal	0 to ±10 VDC (20 kΩ), 0 to 10 VDC (20 kΩ) voltage input or 4 to 20 mA (250 Ω) current input																
Acceleration/Deceleration time	0.01 to 6000.0 s (4 selectable combinations of independent acceleration and deceleration settings)																
Braking torque	Approximately 20% (Increment possible with an external braking resistor.)																
Voltage/frequency characteristics	Select vector control, one from 15 types of fixed V/f patterns, or set a user V/f pattern.																

#### Protective Functions

Model number	3G3FV-	A2004	A2007	A2015	A2022	A2037	A2055	A2075	A2110	A2150	B2185	B2220	B2300	B2370	B2450	B2550	B2750-E
Motor protection	Protection by electronic thermal.																
Instantaneous overcurrent protection	Stops at approx. 200% of rated output current.																
Overload protection	Stops in one minute at approx. 150% of rated output current.																
Overvoltage protection	Stops when main-circuit DC voltage is approx. 410 V.																
Undervoltage protection	Stops when main-circuit DC voltage is approx. 190 V.																
Momentary power interruption compensation (selection)	Stops for 15 ms or more. By selecting the momentary power interruption mode, operation can be continued if power is restored within 2 s.																
Cooling fin overheating	Protection by thermistor.																
Grounding protection	Protection by electronic circuits.																
Charge indicator (internal LED)	Lit when the main circuit DC voltage is approx. 50 V or more.																

#### Environment

Model number	3G3FV-	A2004	A2007	A2015	A2022	A2037	A2055	A2075	A2110	A2150	B2185	B2220	B2300	B2370	B2450	B2550	B2750-E
Location	Indoors (no corrosive gas, oil spray, metallic dust, etc.)																
Ambient operating temperature	-10° to 45°C (Enclosed wall-mounted type: -10° to 40°C)											-10° to 45°C (Panel-mounted type)					
Ambient operating humidity	90% RH max. (with no condensation)																
Storage temperature	-20° to 60°C																
Altitude	1,000 m max.																
Insulation resistance	5 MΩ min. (Do not carry out the insulation resistance test or withstand voltage test.)																
Vibration withstand	Vibration frequency less than 20 Hz, 9.8 m/s <sup>2</sup> max.; 20 to 50 Hz, 2 m/s <sup>2</sup> max																
Protective structure	Both enclosed wall-mounted type and panel-mounted type: IP10											Panel-mounted type: IP00					



# Specifications

## 400-V Inverters

### General Specifications for 400-V Inverters

Model number	3G3FV-	A4004	A4007	A4015	A4022	A4037	A4055	A4075	A4110	A4150	B4185	B4220	B4300	B4370	B4450	B4550	B4750 -E	B411K -E	B416K -E	B418K -E	B422K -E	B430K -E
Max. applicable motor capacity (kW)	0.4	0.75	1.5	2.2	3.7	5.5	7.5	11	15	18.5	22	30	37	45	55	75	110	160	185	220	300	
<b>Output characteristics</b>																						
Rated output capacity (kVA)	1.4	2.6	3.7	4.7	6.1	11	14	21	26	31	37	50	61	73	98	130	170	230	260	340	460	
Rated output current (A)	1.8	3.4	4.8	6.2	8.0	14	18	27	34	41	48	65	80	96	128	165	224	302	340	450	605	
Max. output voltage (V)	3-phase, 380 to 460 VAC (Corresponds to input voltage.)																					
Max. output frequency (Hz)	400 Hz (Set by parameter constant.)																					
<b>Power supply characteristics</b>																						
Rated voltage (V) Rated frequency (Hz)	3-phase, 380 to 460 VAC, 50/60 Hz																					
Allowable voltage fluctuation	-15 to 10%																					
Allowable frequency fluctuation	±5%																					
Power consumption (kW)	0.06	0.09	0.11	0.13	0.15	0.22	0.36	0.46	0.57	0.66	0.88	1.1	1.3	1.4	1.9	2.4	3.1	4.2	5.0	6.9	9.8	
Approximate weight (kg)	3.0	3.0	4.0	4.5	4.5	6.0	6.0	11	11	27	27	44	44	44	79	80	135	145	360	360	420	

### Control Characteristics

Model number	3G3FV-	A4004	A4007	A4015	A4022	A4037	A4055	A4075	A4110	A4150	B4185	B4220	B4300	B4370	B4450	B4550	B4750 -E	B411K -E	B416K -E	B418K -E	B422K -E	B430K -E
Power supply harmonic countermeasures	DC reactor (option) connection possible.											DC reactor built in					No item					
Control method	Sine wave PWM (high-carrier frequency control)																					
Carrier frequency	0.4 to 15 kHz (2.0 to 15 kHz in vector control)											0.4 to 10 kHz (2.0 to 10 kHz in vector control)					0.4 to 2.5 kHz (2.0 to 2.5 kHz in vector control)					
Speed control range	1:100 (1:1000 with PG)																					
Speed control precision	±0.2% (±0.02% with PG)																					
Speed control response	5 Hz (30 Hz with PG)																					
Torque characteristics	150% at 1 Hz (150% at 0 rpm with PG). A torque limit function is incorporated.																					
Torque control precision	±5% (with PG)																					
Torque control response	40 Hz (with PG)																					
Frequency control range	0.1 to 400 Hz																					
Frequency precision (temperature characteristics)	Digital commands: ±0.01% (-10° to 40°C) Analog commands: ±0.1% (25±10°C)																					
Frequency setting resolution	Digital commands: 0.01 Hz (Less than 100 Hz), 0.1 Hz (100 Hz or higher) Analog commands: 0.03 Hz/60 Hz (11 bits + sign)																					
Output frequency resolution	0.01 Hz																					
Overload capacity	150% of rated current for one minute																					
Frequency setting signal	0 to ±10 VDC (20 kΩ), 0 to 10 VDC (20 kΩ) voltage input or 4 to 20 mA (250 Ω) current input																					
Acceleration/Deceleration time	0.01 to 6000.0 s (4 selectable combinations of independent acceleration and deceleration settings)																					
Braking torque	Approximately 20% (Increment possible with an external braking resistor.)																					
Voltage/frequency characteristics	Select vector control, one from 15 types of fixed V/f patterns, or set a user V/f pattern.																					

### Protective Functions

Model number	3G3FV-	A4004	A4007	A4015	A4022	A4037	A4055	A4075	A4110	A4150	B4185	B4220	B4300	B4370	B4450	B4550	B4750 -E	B411K -E	B416K -E	B418K -E	B422K -E	B430K -E
Motor protection	Protection by electronic thermal.																					
Instantaneous overcurrent protection	Stops at approx. 200% of rated output current.																					
Overload protection	Stops in one minute at approx. 150% of rated output current.																					
Overvoltage protection	Stops when main-circuit DC voltage is approx. 820 V.																					
Undervoltage protection	Stops when main-circuit DC voltage is approx. 380 V.																					
Momentary power interruption compensation (selection)	Stops for 15 ms or more. By selecting the momentary power interruption mode, operation can be continued if power is restored within 2 s.																					
Cooling fin overheating	Protection by thermistor.																					
Grounding protection	Protection by electronic circuits.																					
Charge indicator (Internal LED)	Lit when the main circuit DC voltage is approx. 50 V or more.																					

### Environment

Model number	3G3FV-	A4004	A4007	A4015	A4022	A4037	A4055	A4075	A4110	A4150	B4185	B4220	B4300	B4370	B4450	B4550	B4750 -E	B411K -E	B416K -E	B418K -E	B422K -E	B430K -E
Location	Indoors (no corrosive gas, oil spray, metallic dust, etc.)																					
Ambient operating temperature	-10° to 45°C (Enclosed wall-mounted type: -10° to 40°C)											-10° to 45°C (Panel-mounted type)										
Ambient operating humidity	90% RH max. (with no condensation)																					
Storage temperature	-20° to 60°C																					
Altitude	1,000 m max.																					
Insulation resistance	5 MΩ min. (Do not carry out the insulation resistance test or withstand voltage test.)																					
Vibration withstand	Vibration frequency less than 20 Hz, 9.8 m/s <sup>2</sup> max.; 20 to 50 Hz, 2 m/s <sup>2</sup> max																					
Protective structure	Both enclosed wall-mounted type and panel-mounted type: IP10											Panel-mounted type: IP00										

# Terminal Block

## ■ Terminal Block Configuration

Example: 200 V, 0.4 kW

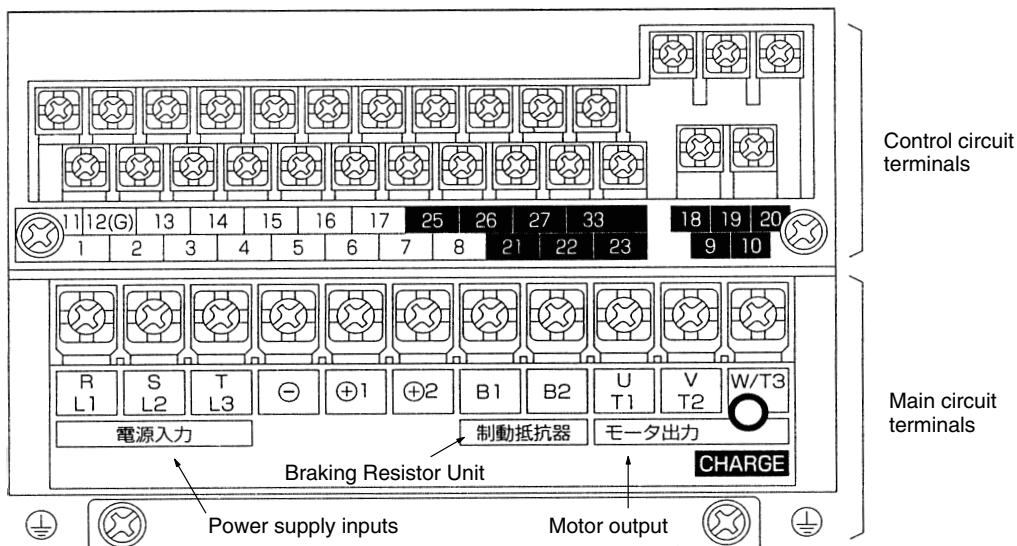

## ■ Main Circuit Terminals

### 200-V Inverters

Model number (Capacity)	3G3FV-A2004 to 3G3FV-A2075 (0.4 to 7.5 kW)	3G3FV-A2110 to 3G3FV-A2150 (11 to 15 kW)	3G3FV-B2185 to 3G3FV-B2220 (18.5 to 22 kW)	3G3FV-B2300 to 3G3FV-B2750-E (30 to 75 kW)
R, S, T	Power supply input terminals, 3-phase, 200 to 230 VAC, 50/60 Hz			
U, V, W	Motor output terminals, 3-phase, 200 to 230 VAC (correspond to input voltage)			
B1 B2	Braking Resistor Unit connection terminals	---		
+1	DC reactor connection terminals (+1 - +2)	DC reactor connection terminals (+1 - +2)	DC power supply input terminals (+1 - -)	---
+2	DC power supply input terminals (+1 - -)	DC power supply input terminals (+1 - -)	Braking Unit connection terminals (+3 - -)	Braking Unit connection terminals (+3 - -)
-		Braking Unit connection terminals (+3 - -)		
+3	---			
s	---		Cooling fan power supply input terminals	See note.
r	---			
s200	---			
s400	---			
⊥	Ground terminal (Ground to 100 Ω or less.)			

Note: The s and r terminals are cooling fan and control circuit power supply input terminals.

### 400-V Inverters

Model number (Capacity)	3G3FV-A4004 to 3G3FV-A4150 (0.4 to 15 kW)	3G3FV-B4185 to 3G3FV-B4450 (18.5 to 45 kW)	3G3FV-B4550 to 3G3FV-B416K-E (55 to 160 kW)	3G3FV-B418K-E to 3G3FV-B430K-E (185 to 300 kW)
R, S, T	Power supply input terminals, 3-phase, 380 to 460 VAC, 50/60 Hz			
U, V, W	Motor output terminals, 3-phase, 380 to 460 VAC (corresponds to input voltage)			
B1 B2	Braking Resistor Unit connection terminals	---		
+1	DC reactor connection terminals (+1 - +2)	DC power supply input terminals (+1 - -)	---	DC power supply input terminals (+1 - -)
+2	DC power supply input terminals (+1 - -)	Braking Unit connection terminals (+3 - -)	Braking Unit connection terminals (+3 - -)	---
-				Braking Unit connection terminals (+3 - -)
+3	---			
s	---	Cooling fan power supply input terminals	---	---
r	---		See note.	See note.
s200	---			
s400	---			
⊥	Ground terminal (Ground to 10 Ω or less.)			

Note: The r, s200, and s400 terminals are cooling fan and control circuit power supply input terminals. Apply 380 to 460 VAC between the r and s400 terminals when using a 400-V input. Apply 200 to 230 VAC between the r and s200 terminals when using a 200-V input.

# Terminal Block

## ■ Control Circuit Terminal Common to Both 200-V and 400-V Classes

Symbol	Name	Function	Signal level
Input	1	Forward/Stop	Starts at ON and stops at OFF.
	2	Reverse/Stop	Starts at ON and stops at OFF.
	3	Multi-function contact input 1	Set by the constant (H1-01) (external error a).
	4	Multi-function contact input 2	Set by the constant (H1-02) (error reset).
	5	Multi-function contact input 3	Set by the constant (H1-03) (multistep speed reference 1).
	6	Multi-function contact input 4	Set by the constant (H1-04) (multistep speed reference 2).
	7	Multi-function contact input 5	Set by the constant (H1-05) (inching reference).
	8	Multi-function contact input 6	Set by the constant (H1-06) (external base block).
	11	Sequence input common	Common for terminals 1 to 8.
Analog input	15	Frequency reference power supply (+15 VDC)	+15 VDC power supply for frequency reference.
	33	Frequency reference power supply (-15 VDC)	-15 VDC power supply for frequency reference.
	13	Frequency reference input (voltage)	Voltage input terminal for frequency reference. Select 0 to 10 V or 0 to ±10 V with the constant (H3-01).
	14	Frequency reference input (current)	Current input terminal for frequency reference.
	16	Multi-function analog input	Set by the constant (H3-05).
	17	Frequency reference input common	Analog input signal common
	12	Shielded wire connection ground	Shielded terminal for sequence and frequency reference inputs.
Sequence output	9	Multi-function contact output	Set by the constant (H2-01) (operating).
	10	Multi-function contact output common	
	25	Multi-function output 1	Set by the constant (H2-02) (zero speed detection).
	26	Multi-function output 2	Set by the constant (H2-03) (speed conformity detection)
	27	Multi-function output common	Common for terminals 25 and 26
	18	Error output (normally open)	Terminals 18 and 20 are closed and terminals 19 and 20 are open when an error occurs.
	19	Error output (normally closed)	
20	Error output common		
Analog output	21	Multi-function analog output 1	(Output frequency: 0 to ±10 V/±100% frequency) set with the constant (H4-01).
	23	Multi-function analog output 2	(Output current: 5 V/inverter rated current) set with the constant (H4-04).
	22	Multi-function analog output common	Analog output common

**Note:** The settings in parentheses in the above function column are the factory settings.

# Dimensions

## ■ Dimensions

3G3FV-A2□□□□/A4□□□□

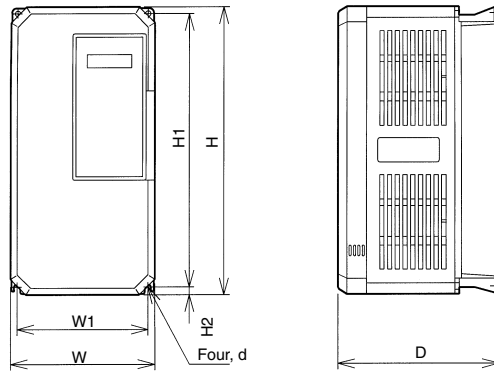

### • 200-V Class

Model 3G3FV-	Max. applied motor capacity (kW)	Dimensions (mm)							Mounting screws	Approx. weight (kg)
		W	H	D	W1	H1	H2	d		
A2004	0.4	140	280	160	126	266	7.0	M5	3	
A2007	0.75									
A2015	1.5									
A2022	2.2	140	280	180	126	266	7.0	M5	4.5	
A2037	3.7									
A2055	5.5									
A2075	7.5	200	300	205	186	285	8.0	M6	5.5	
A2110	11								6.0	
A2150	15									
		250	380	225	236	365	7.5	M6	11	
			400							27.5

### • 400-V Class

Model 3G3FV-	Max. applied motor capacity (kW)	Dimensions (mm)							Mounting screws	Approx. weight (kg)
		W	H	D	W1	H1	H2	d		
A4004	0.4	140	280	160	126	266	7.0	M5	3.0	
A4007	0.75									
A4015	1.5									
A4022	2.2	140	280	180	126	266	7.0	M5	4.0	
A4037	3.7									
A4055	5.5									
A4075	7.5	200	300	205	186	285	8.0	M6	6.0	
A4110	11								6.0	
A4150	15									
		250	380	225	236	365	7.5	M6	11	
			400							27.5

3G3FV-B2□□□□/B4□□□□ (B4 Models: 160 kW Max.)

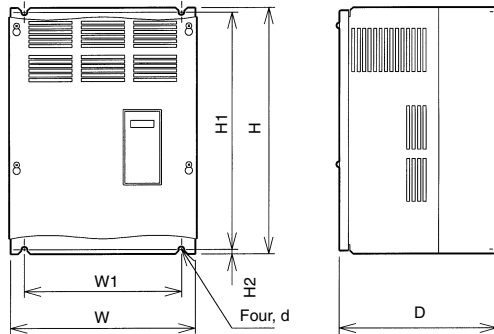

### • 200-V Class

Model 3G3FV-	Max. applied motor capacity (kW)	Dimensions (mm)							Mounting screws	Approx. weight (kg)
		W	H	D	W1	H1	H2	d		
B2185	18.5	325	450	285	275	435	7.5	M6	28	
B2220	22									
B2300	30	425	675	350	320	650	12.5	M10	61	
B2370	37									
B2450	45	475	800	350	370	775	12.5	M10	80	
B2550	55									
B2750-E	75	575	925	400	445	895	15.0	M12	135	

### • 400-V Class

Model 3G3FV-	Max. applied motor capacity (kW)	Dimensions (mm)							Mounting screws	Approx. weight (kg)
		W	H	D	W1	H1	H2	d		
B4185	18.5	325	450	285	275	435	7.5	M6	27	
B4220	22									
B4300	30	325	625	285	275	610	7.5	M6	44	
B4370	37									
B4450	45	455	820	350	350	795	12.5	M10	79	
B4550	55									
B4750-E	75	575	925	375	445	895	15.0	M12	135	
B411K-E	110									
B416K-E	160		400						145	

# Dimensions

## 3G3FV-B4□□□-E (185 kW Min.)

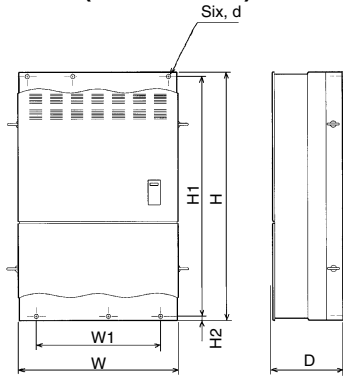

### • 400-V Class

Model 3G3FV-	Max. applied motor capacity (kW)	Dimensions (mm)						Mount- ing screws	Approx. weight (kg)
		W	H	D	W1	H1	H2		
B418K-E	185	950	1450	435	750	1400	25	M12	360
B422K-E	220					1550			
B430K-E	300	960	1600	455					420

# Wiring

## ■ Main Circuit Terminal Connections

### 3G3FV-A2004 to A2075, A4004 to A4150

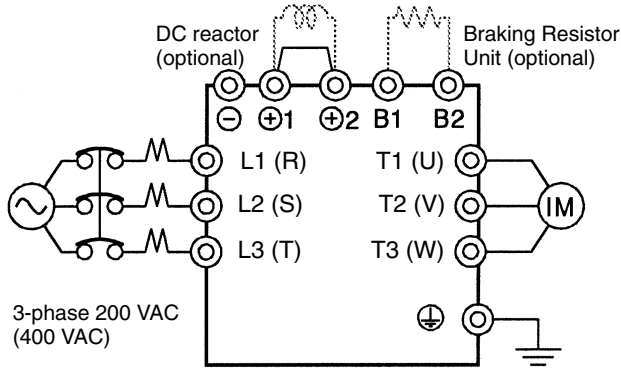

**Note:** Be sure to remove the short bar before connecting a DC reactor.

### 3G3FV-A2110 to A2150

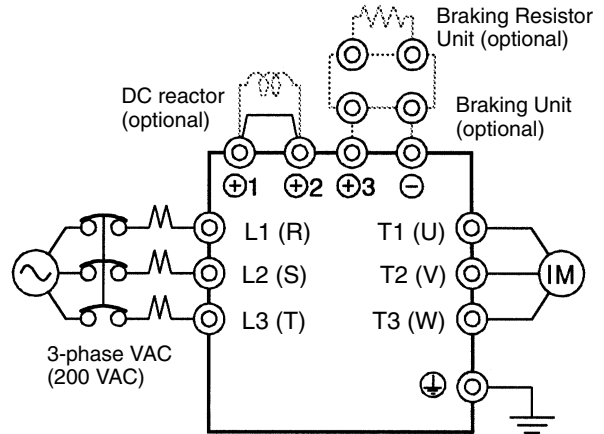

**Note:** Be sure to remove the short bar before connecting a DC reactor.

### 3G3FV-B2185 to B2220, B4185 to B4450

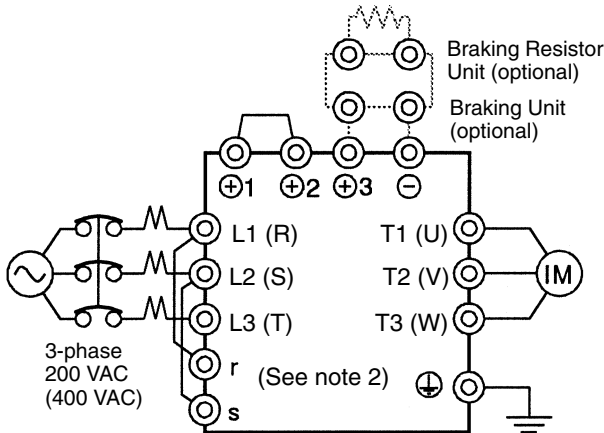

**Note:** The DC reactor is built in.

### 3G3FV-B2300 to B2750-E

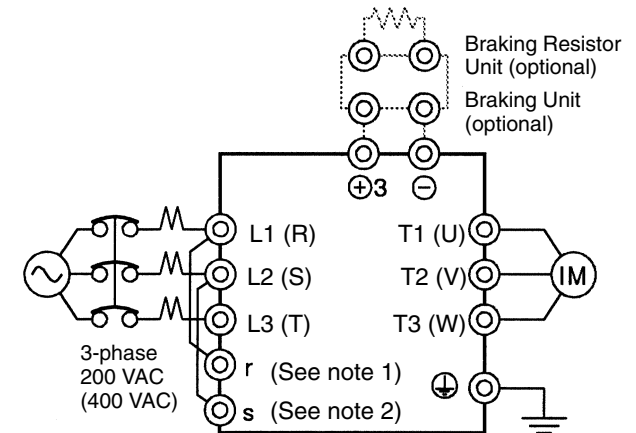

**Note:** The DC reactor is built in.

### 3G3FV-B4550 to B430K-E

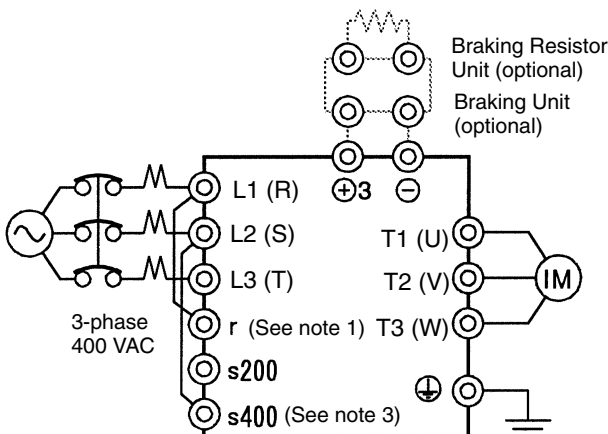

**Note:** The DC reactor is built in.

- Note:**
1. For 200-V class, 30 to 75 kW (B2300 to B2750-E) and 400-V class, 55 to 300 kW (B4550 to B430K-E), input the control circuit power supply from r-s. (For others, create the control power supply internally from the main circuit DC power supply.)
  2. The r-L1 (R) and s-L2 (S) terminals are short-circuited for shipping.
  3. The r-L1 (R) and s (s400)-L2 (S) terminals are short-circuited for shipping.

## ■ Control Circuit Terminal Connections (All Models)

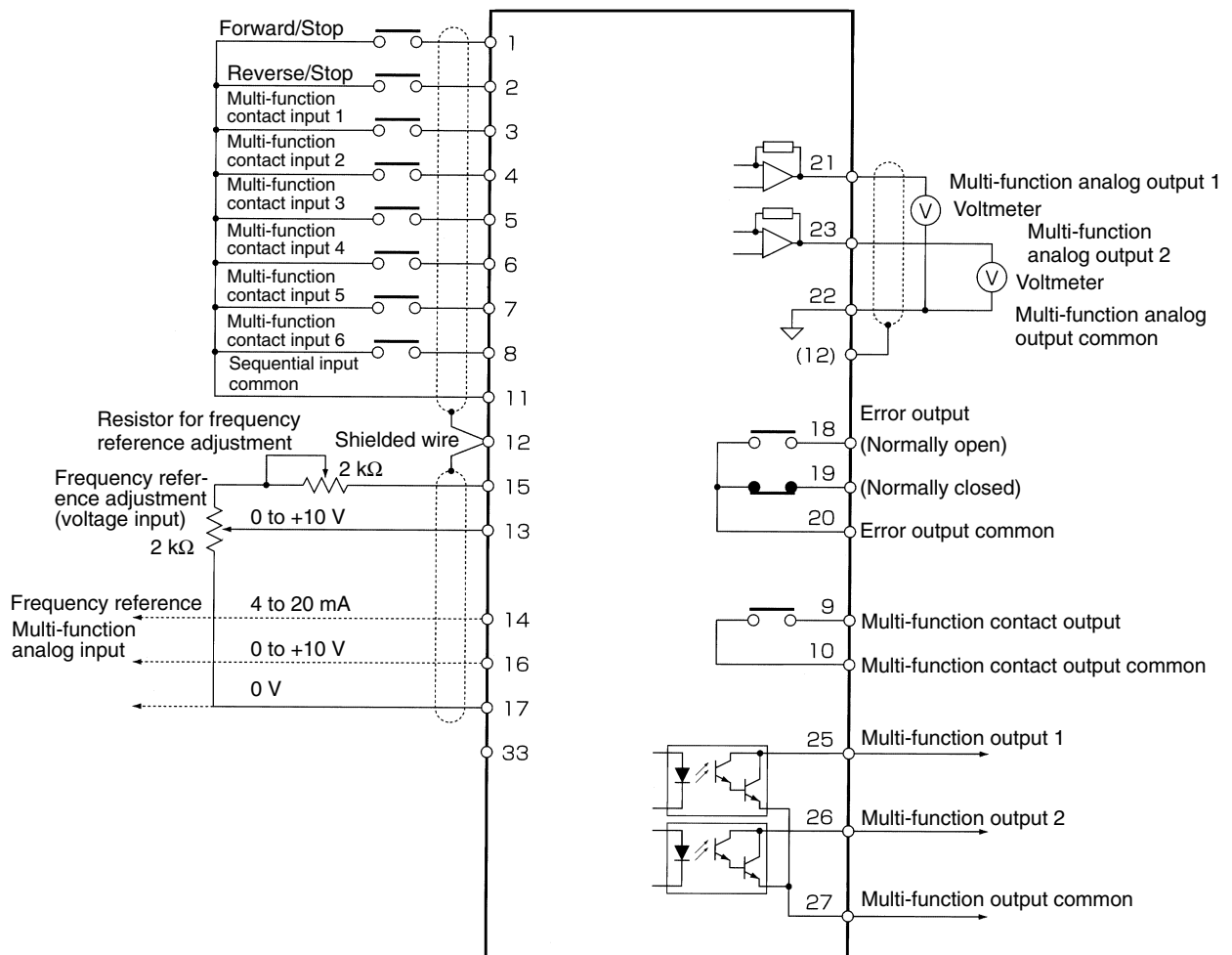

# Options

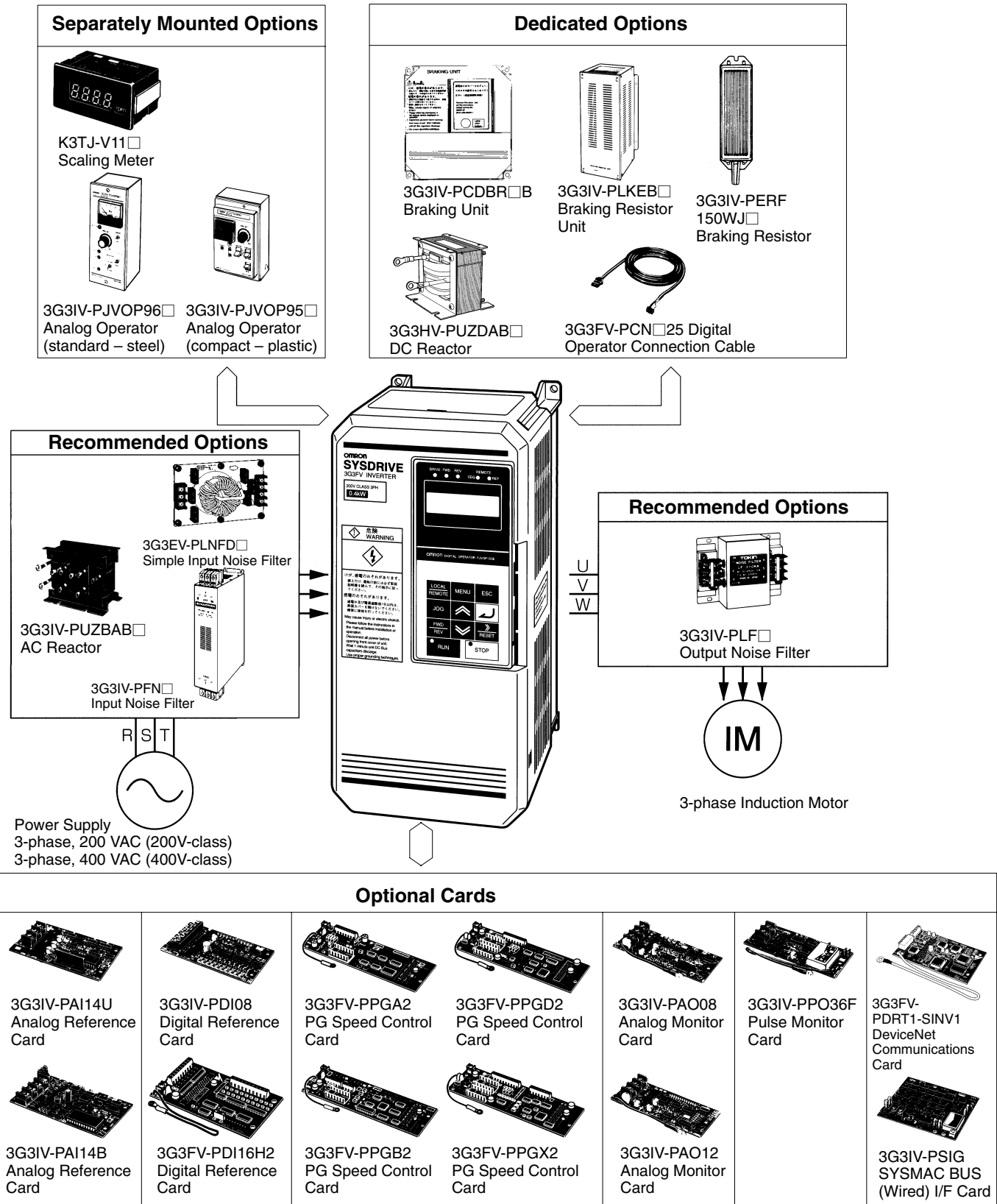



## ■ Separately Mounted Options

Name	Model	Descriptions
Scaling Meter	K3TJ-V11□	Connects to the multi-functional analog output of the Inverter. It displays the rotational speed of a machine or the line speed.
Analog Operator (steel: standard type)	3G3IV-PJVOP96□	Allows frequency reference settings and ON/OFF operation control to be performed by analog commands from a remote location (50 m max.). Frequency counter specifications: 75 Hz, 150 Hz, 220 Hz
Analog Operator (plastic: compact type)	3G3IV-PJVOP95□	Allows frequency reference settings and ON/OFF operation control to be performed by analog commands from a remote location (50 m max.). Frequency counter specifications: 60/120 Hz, 90/180Hz

## ■ Dedicated Options

Name	Model	Descriptions
Braking Unit	3G3IV-PCDBR□B	Used in combination with a Braking Resistor Unit for reducing motor's deceleration time. Not necessary for 200V-class models of 7.5 kW max. or 400V-class models of 15 kW max.
Braking Resistor Unit	3G3IV-PLKEB□	Consumes the regenerative energy of the motor and reduces the deceleration time of the motor.
Braking Resistor	3G3IV-PERF150WJ□	Used for 200-V class of 3.7 kW max. and 400-V class of 2.2 kW max. Consumes the regenerative energy of the motor and reduces the deceleration time of the motor.
DC Reactor	3G3HV-PUZDAB□	Suppresses the harmonic currents of the 3G3FV and improves the power factor of the 3G3FV. Models of 18.5 kW or more have a built-in DC Reactor.
Digital Operator Connection Cable	3G3FV-PCN125 (1 m) 3G3FV-PCN325 (3 m)	A dedicated cable for the 3G3FV Series. Used to connect the 3G3FV and Digital Operator when they are separated.

## ■ Optional Cards

Name	Model	Descriptions
Analog Reference Card	3G3IV-PAI14U	The 3G3FV incorporates analog input terminals for frequency references with a resolution of 1/2,048. This card increases the resolution to 1/16,384.
	3G3IV-PAI14B	Allows -10- to 10-VDC frequency reference inputs with a resolution of 1/8,192 + mark. Forward and reverse rotation is selected with the polarity of the input voltage.
Digital Reference Card	3G3IV-PDI08	Used to set frequency references in 2-digit BCD or 8-bit binary.
	3G3FV-PDI16H2	Used to set frequency references with 16 or 12 bits (switchable). A parameter setting can be used to select BCD or binary data. The card incorporates a 24-VDC battery (8 mA max.).
Analog Monitor Card	3G3IV-PAO08	Makes it possible to use the analog output of the terminals as control signals. The card, which has two-point, 0 to 10 V analog output, is used to monitor the output frequency, output current, output voltage reference, or DC voltage of the 3G3FV. The 3G3IV-PAO08 has an output resolution of 1/256 (output voltage of 0 to 10 V) and the 3G3IV-PAO12 has an output resolution of 1/2,048 (output voltage of 0 to ±10 V).
	3G3IV-PAO12	
Pulse Monitor Card	3G3IV-PPO36F	Used to output pulse-train signals according to the output frequency of the 3G3FV. The pulse-train signals can be input to another device such as a frequency meter or counter.
PG Speed Control Card	3G3FV-PPGA2	Used for V/f control using the PG at a maximum response frequency of 30 kHz for phase-A (single) pulse input and open-collector output. Pulse monitor output is incorporated.
	3G3FV-PPGB2	Used for vector control using the PG at a maximum response frequency of 30 kHz for phase-A/phase-B inputs and open-collector output. Pulse monitor output is incorporated.
	3G3FV-PPGD2	Used for V/f control using the PG at a maximum response frequency of 300 kHz for phase-A (single) pulse input and RS-422 line driver input. Pulse monitor output is incorporated.
	3G3FV-PPGX2	Used for vector control using the PG at a maximum response frequency of 300 kHz for phase-A/phase-B/phase-Z pulse inputs and RS-422 line driver input. Pulse monitor output is incorporated.
DeviceNet Communications Card	3G3FV-PDRT1-SINV1	Used for communications between a Programmable Controller or another Master Unit and the DeviceNet system.
SYSMAC BUS (Wired) I/F Card	3G3IV-PSIG	Used for communications between a Programmable Controller and the SYSMAC BUS (Wired) system.

- Note:** 1. Use the Digital Reference Card when setting frequencies digitally from a PC's Output Unit or thumbwheel switches.  
2. Use the PG Speed Control Card for speed control with the Pulse Generator (PG).

## ■ Recommended Options

Name	Model	Descriptions
AC Reactor	3G3IV-PUZBAB□	Used if the harmonic currents of the 3G3FV must be suppressed or the capacity of the power supply connected to the 3G3FV is much larger than the capacity of the 3G3FV. The AC Reactor improves the power factor of the 3G3FV.
Simple Input Noise Filter (Yaskawa Electric)	3G3EV-PLNFD□	Used to eliminate noise coming into the Inverter from the power supply line and to reduce noise flowing from the Inverter into the power supply line. Connect to the power supply input side.
Input Noise Filter (Schaffner)	3G3IV-PFN□	Used to eliminate noise coming into the Inverter from the power supply line and to reduce noise flowing from the Inverter into the power supply line. Connect to the power supply input side.
Output Noise Filter	3G3IV-PLF□	Used to suppress noise that is generated by the Inverter from affecting the power supply side. Connect to the motor output side.

# Options

## ■ 3G3FV-PDRT1-SINV1 DeviceNet Communications Card

Used for DeviceNet communications between an OMRON Programmable Controller's Master Unit, or other controller, and the SYS-DRIVE 3G3FV.

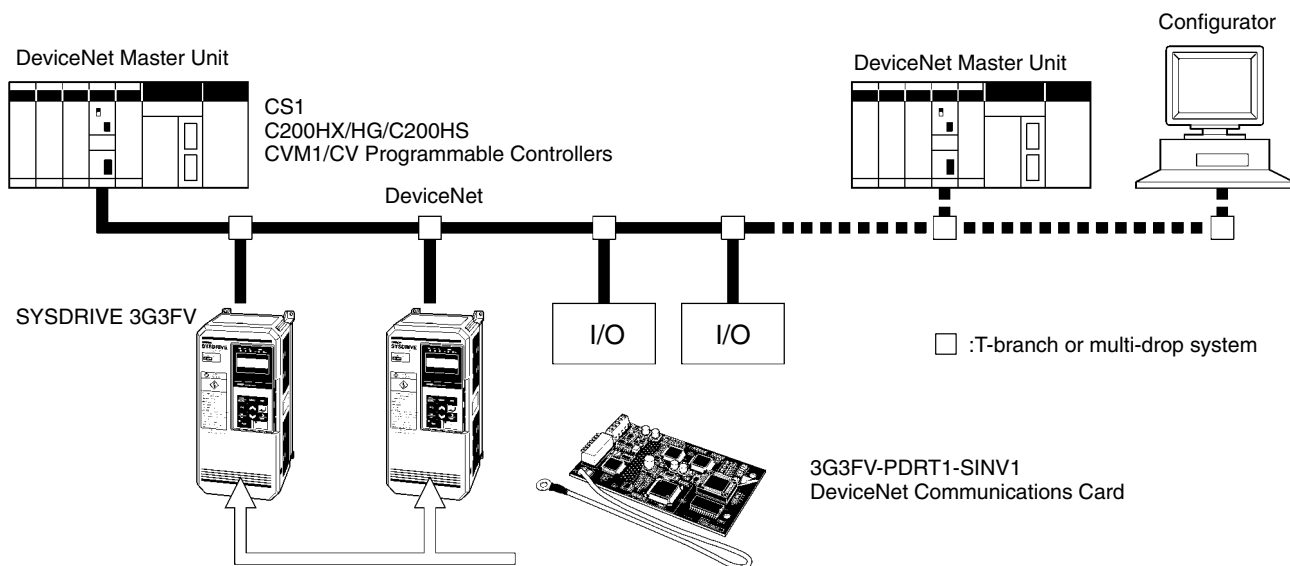

## Specifications

Item	Communications		
Connection method	T-branch or multi-drop method		
Communications baud rate	500,000/250,000/125,000 bps		
Communications cycle time	Approx. 10, 20, or 40 ms		
Communications cable	Special 5-conductor cable		
Maximum number of Units connected (See note 1.)	Configurator	Message function	Number of Units
	1 Used	Not used	63 Units
	2 Used	Used	25 Units
3 Not used	Not used, used	25 Units	
Remote I/O words occupied	2 words for input and 2 words for output (See note 2)		

**Note:** 1. For C200HX/HG/HE.

2. Switchable to 3-word input and 3-word output.

## Wiring Example

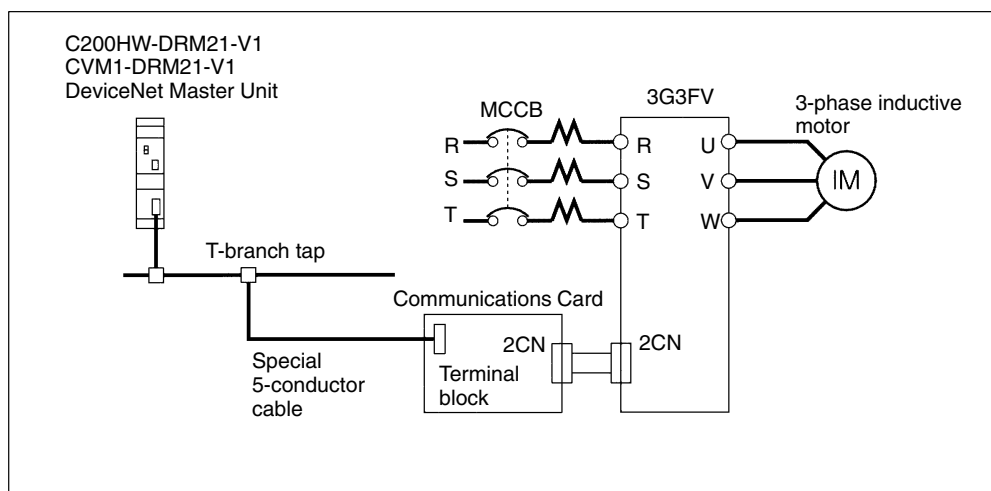

## ■ 3G3IV-PSIG Wired SYSMAC BUS Interface Card

Used for communications with a Programmable Controller via the Wired SYSMAC BUS.

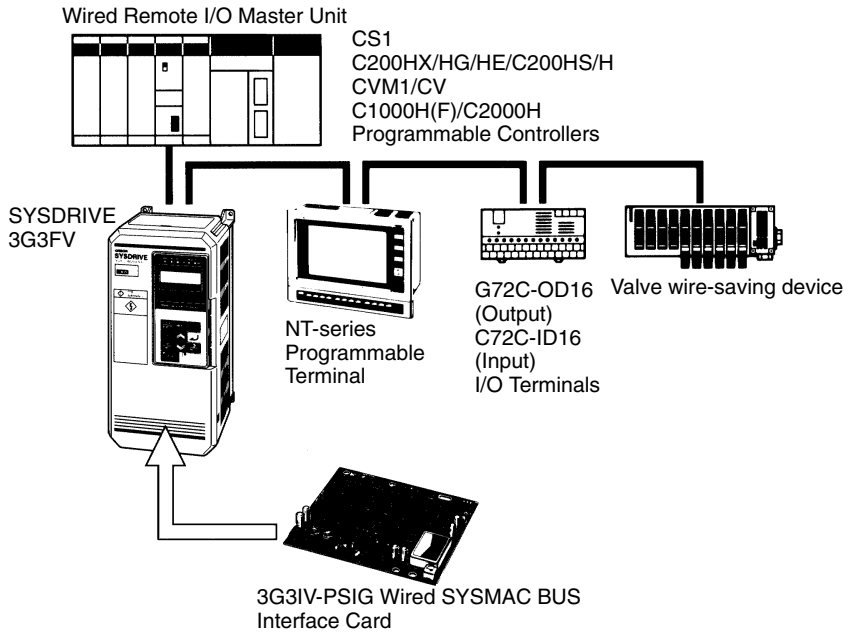

## Wiring Example

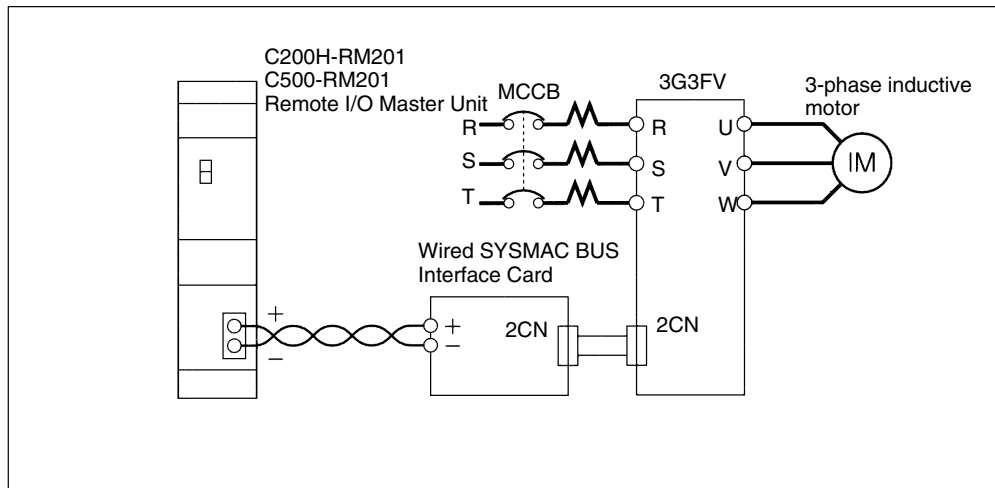

# Standard Models

## ■ Standard Models

Voltage class	Protective structure	Maximum applied motor capacity	Model	
200-V class	Enclosed wall-mounted type	0.4 kW	3G3FV-A2004	
		0.75 kW	3G3FV-A2007	
		1.5 kW	3G3FV-A2015	
		2.2 kW	3G3FV-A2022	
		3.7 kW	3G3FV-A2037	
		5.5 kW	3G3FV-A2055	
		7.5 kW	3G3FV-A2075	
		11 kW	3G3FV-A2110	
		15 kW	3G3FV-A2150	
	Panel-mounted type	18.5 kW	3G3FV-B2185	
		22 kW	3G3FV-B2220	
		30 kW	3G3FV-B2300	
		37 kW	3G3FV-B2370	
		45 kW	3G3FV-B2450	
		55 kW	3G3FV-B2550	
		75 kW	3G3FV-B2750-E	
		400-V class	Enclosed wall-mounted type	0.4 kW
0.75 kW	3G3FV-A4007			
1.5 kW	3G3FV-A4015			
2.2 kW	3G3FV-A4022			
3.7 kW	3G3FV-A4037			
5.5 kW	3G3FV-A4055			
7.5 kW	3G3FV-A4075			
11 kW	3G3FV-A4110			
15 kW	3G3FV-A4150			
Panel-mounted type	18.5 kW			3G3FV-B4185
	22 kW			3G3FV-B4220
	30 kW			3G3FV-B4300
	37 kW		3G3FV-B4370	
	45 kW		3G3FV-B4450	
	55 kW		3G3FV-B4550	
	75 kW		3G3FV-B4750-E	
	110 kW		3G3FV-B411K-E	
	160 kW		3G3FV-B416K-E	
	185 kW		3G3FV-B418K-E	
	220 kW		3G3FV-B422K-E	
	300 kW		3G3FV-B430K-E	

## ■ Model Numbers

**3G3FV-A2037-CUE**

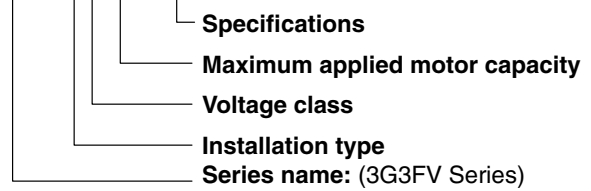

### Specifications

<b>None</b>	Japanese model
<b>-E</b>	English model
<b>-CE</b>	Model conforming to EN standards
<b>-CUE</b>	Model conforming to EN and UL/cUL standards

### Maximum Applied Motor Capacity

<b>004</b>	0.4 kW
<b>007</b>	0.75 kW
<b>015</b>	1.5 kW
<b>022</b>	2.2 kW
<b>037</b>	3.7 kW
<b>055</b>	5.5 kW
<b>075</b>	7.5 kW
<b>110</b>	11 kW
<b>150</b>	15 kW
<b>185</b>	18.5 kW
<b>220</b>	22 kW
<b>300</b>	30 kW
<b>370</b>	37 kW
<b>450</b>	45 kW
<b>550</b>	55 kW
<b>750</b>	75 kW
<b>11K</b>	110 kW
<b>16K</b>	160 kW
<b>18K</b>	185 kW
<b>22K</b>	220 kW
<b>30K</b>	300 kW

### Voltage Class

<b>2</b>	3-phase, 200 VAC (200-V class)
<b>4</b>	3-phase, 400 VAC (400-V class)

### Installation Type

<b>A</b>	Panel-mounting (IP10 min.) or closed wall-mounting models
<b>B</b>	Panel-mounting (IP00)