

### No Power Supply Required

### Replaces K-type Thermocouple without Modification

- No Power Supply Required:**  
 The ES1A has electromotive output as high as that of a thermocouple, thus connecting directly to the thermocouple input terminal of the Temperature Controller with no external power supply required.
- One-tenth the Size of OMRON's Conventional Models:**  
 The ES1A-A is as compact as 14 x 18.6 x 34 (W x H x D) and can be built into machines and equipment with ease.
- Available at High Ambient Temperature:**  
 The ES1A Series performs accurate measurement without being influenced by the ambient temperature. The ES1A-C incorporates an air purge function, thus air-cooling itself and operating at a maximum of 120°C.

| Model  | Ambient temperature |
|--------|---------------------|
| ES1A-A | -25°C to 70°C       |
| ES1A-B | -25°C to 100°C      |
| ES1A-C | -25°C to 120°C      |

- Four Temperature Ranges (10°C to 260°C) Selectable:**  
 Four temperature ranges are available to cover a wide range of temperature measurement needs including those in the food processing, packaging, and electronics industries. The linearity of the ES1A Series in any of the available temperature ranges is excellent. Therefore, highly precise temperature measurement is ensured.
- High-speed Response and High Reproducibility:**  
 High-precision temperature measurement is ensured by a high-speed response of 300 ms and an indicator reproducibility of  $\pm 0.1\%$  PV. Unlike thermocouples, the sensor does not deteriorate. Therefore, stable, real-time temperature control can be maintained. The 300-ms response time is ensured at a response rate of 63%.

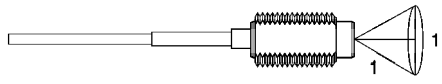
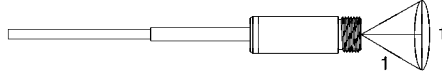
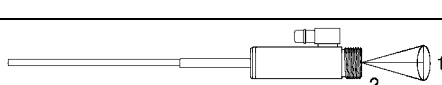
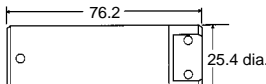

## Ordering Information

| Model  | Temperature range         | Appearance and sensing characteristic (at 50% energy)   |
|--------|---------------------------|---|
| ES1A-A | 10°C to 70°C              |  Casing material: Hard ABS resin<br>Sensing distance vs. sensing diameter: 1 to 1 (See note.)                                |
|        | 60°C to 120°C             |   |
|        | 115°C to 165°C            |   |
| ES1A-B | 10°C to 70°C              |  Casing material: Stainless (SUS303)<br>Sensing distance vs. sensing diameter: 1 to 1 (See note.)                            |
|        | 60°C to 120°C             |   |
|        | 115°C to 165°C            |   |
|        | 160°C to 260°C            |   |
| ES1A-C | 10°C to 70°C              |  Casing material: Stainless (SUS303)<br>With air purge function<br>Sensing distance vs. sensing diameter: 2 to 1 (See note.) |
|        | 60°C to 120°C             |   |
|        | 115°C to 165°C            |   |
|        | 160°C to 260°C            |   |
| ES1A-J | Cooling Jacket for ES1A-C |    |

**Note:** The spot diameter of the vision range is for 50% energy. For actual objects to be measured, set the spot diameter to 1.5 times larger than that for 50% energy.

# Application Examples

## Temperature Measurement at Thermo-compression Bonding Stage of Packages

### Temperature Control of Ironing Portion

At the thermo-compression bonding stage of packages, the temperature of the ironing portion is measured to keep it constant, thus reducing the number of improperly bonded packages and simplifying the inspection of the finished packages.

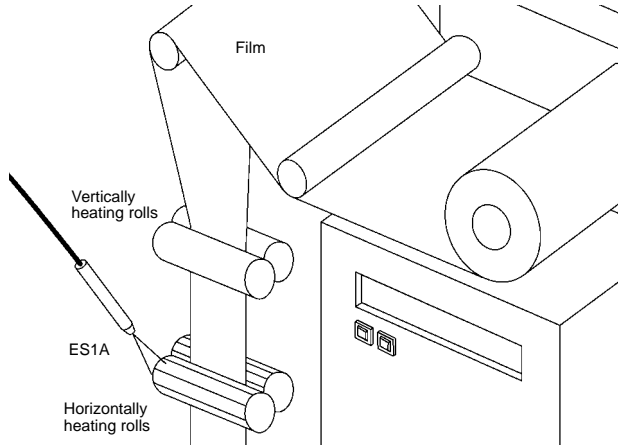

## Fine Molding

### Temperature Measurement of Sheet Molding Machines and Resin Extrusion Machines

The temperature measurement of molded resin products or semi-finished products output from molding machines or extrusion machines, or the temperature measurement of the material in the nozzles with heaters can be performed with ease.

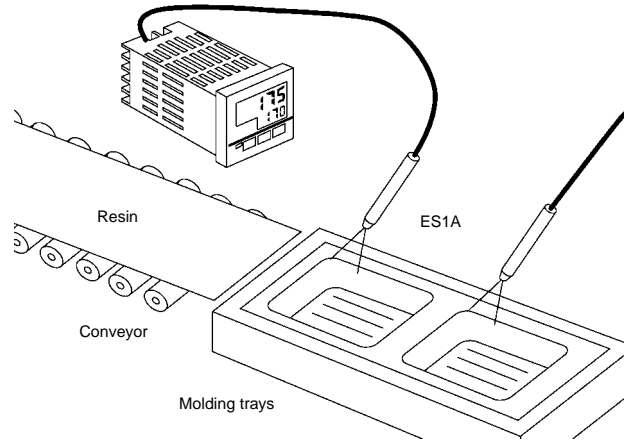

## Hygienic Food and Drug Processing

### Temperature Measurement of Cookies

At the cooling stage or baking stage of dough, the temperature of each piece of dough can be measured without contact, which allows construction of hygienic, highly efficient systems without fear of damage to the finished products.

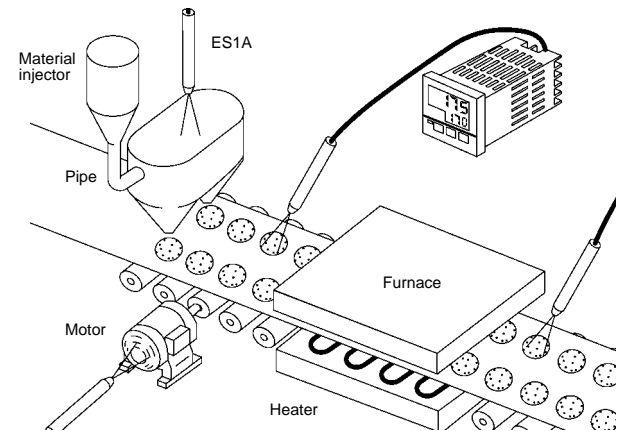

## Monitoring Hot-melt Adhesive Application (with Measurement of Temperature Difference)

### Monitoring Hot-melt Adhesive Application

The temperature of the adhesive injected at the bonding stage is measured. From the difference in temperature between the adhesive-applied portions and those not applied yet, the condition of adhesive application is determined.

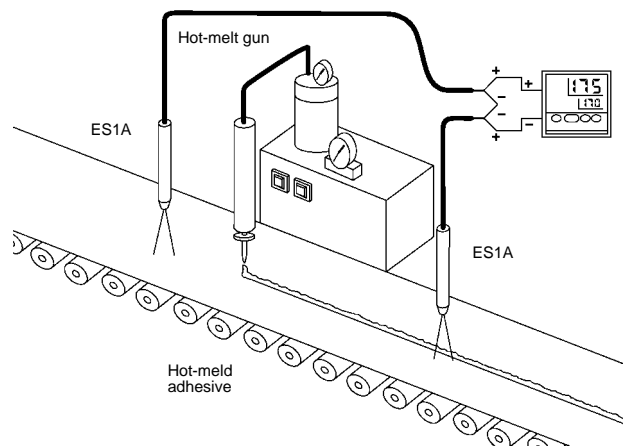

## Maintenance and Inspection of High-tension Distribution Boards

### Detecting Excessive Heat Radiation of High-tension Distribution Boards or Transformers

By detecting the excessive heat radiation of high-tension parts, checks for failures in these parts can be performed without contact. These checks prevent accidents from resulting, ensure the safety of the parts, and save maintenance effort.

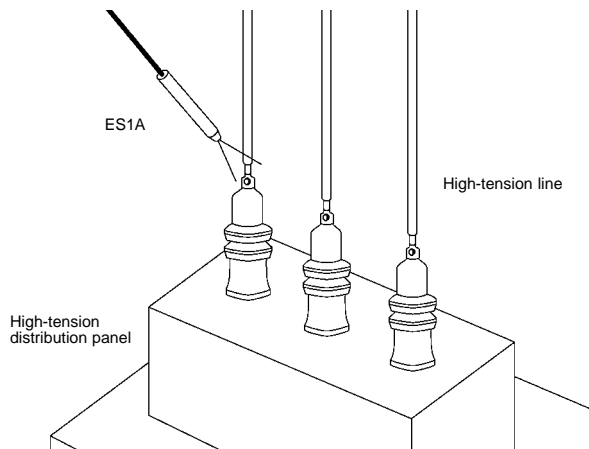

## Applicable to High-speed Rotating Parts

### Detecting Excessive Heat Radiation of Bearings

By detecting the excessive heat radiation of bearings, checks for oil shortage and any defect in the bearings can be performed. These checks prevent accidents from resulting.

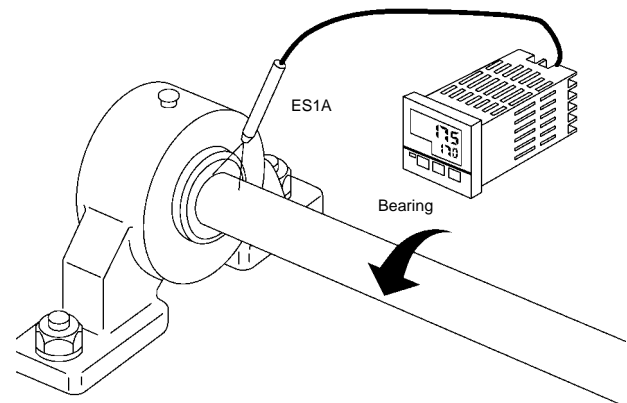

## Specifications

### ■ Ratings

| Item   | ES1A-A   | ES1A-B   | ES1A-C  |
|--|--|--|---|
| Temperature range  | 10°C to 70°C, 60°C to 120°C, 115°C to 165°C                                    | 10°C to 70°C, 60°C to 120°C, 115°C to 165°C, 160°C to 260°C  |   |
| Precision<br>(Based on characteristics of K-type thermocouple and radiation rate of 0.9) | Temperature change from reference temperature of sensing objects               | Accuracy   |   |
|  | ±5°C<br>±10°C<br>±30°C<br>±40°C  | ±2% PV or ±2°C, whichever is larger.<br>±4% PV or ±4°C, whichever is larger.<br>±6% PV or ±6°C, whichever is larger.<br>±8% PV or ±8°C, whichever is larger. |   |
| Reproducibility  | ±1% PV or ±1°C, whichever is larger.   |  |   |
| Temperature drift  | 0.4°C/°C max.  |  |   |
| Sensing distance vs. sensing diameter  | 1:1 typ.   |  | 2:1 typ.  |
| Measurement wavelength   | 6.5 to 14.0 μm   |  |   |
| Receiver element   | Thermopile   |  |   |
| Response speed   | Approximately 300 ms at response rate of 63%                                   |  |   |
| Output impedance   | 1 to 4 kΩ  |  | 3 to 10 kΩ  |
| Ambient operating temperature<br>(with no icing or condensation)                         | -25°C to 70°C  | 10°C to 70°C, 60°C to 120°C models:  | -25°C to 85°C   |
|  |  | 115°C to 165°C, 160°C to 260°C models:   | -25°C to 100°C  |
|  |  | With no icing or condensation  | At 120°C max. in air purge operation and 250°C max. with the Cooling Jacket used, provided that there is no icing or condensation |
| Ambient humidity   | Operating: 35% to 85%  |  |   |
| Vibration resistance   | 100 m/s <sup>2</sup> for 2 hours each in X, Y, and Z directions at 10 to 55 Hz |  |   |
| Shock resistance   | 300 m/s <sup>2</sup> for 3 times each in X, Y, and Z directions.               |  |   |
| Casing material  | Hard ABS resin   | SUS303   |   |
| Degree of protection   | IP65   |  | IP60  |
| Weight   | 55 g   | 65 g   | 70 g  |
| Cable  | Compensating conductor: 3 m  |  | Thermocouple cable: 3 m   |
|  | PVC-covered cable with a shielded wire resisting 70°C.                         |  | Teflon-covered cable resisting 180°C.   |

# Dimensions

**Note:** All units are in millimeters unless otherwise indicated.

## ES1A-A

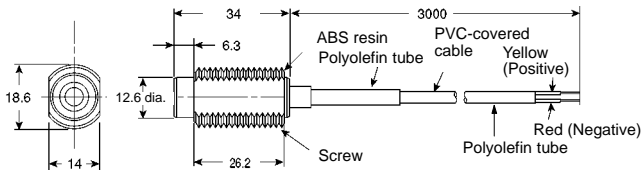

## Mounting Lock Nuts (Two)

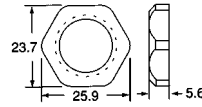

## ES1A-B

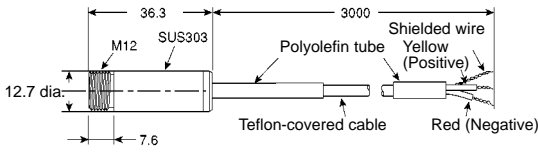

## Mounting Bracket (One)

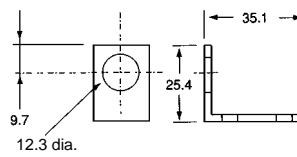

## ES1A-C

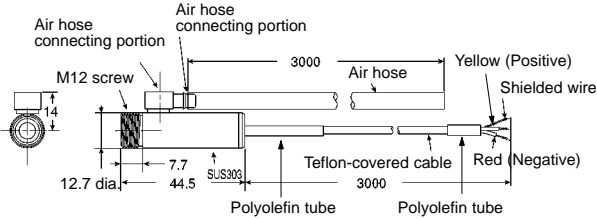

## Panel Nut (Two)

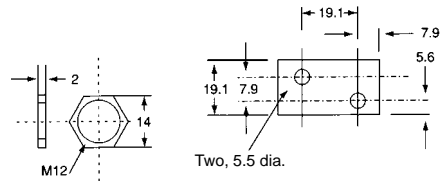

# Installation

## ■ Connections

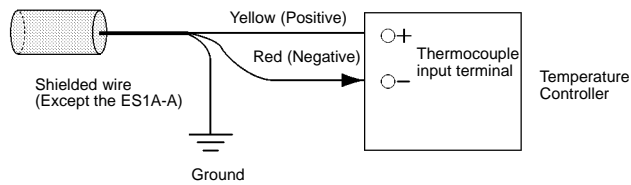

# Precautions

## ■ Adjustments

Be sure to adjust the Sensor before use according to the condition of the sensing objects and the characteristics of the Temperature Controller.

### Offset Compensation for Target Value with Input Compensating Function

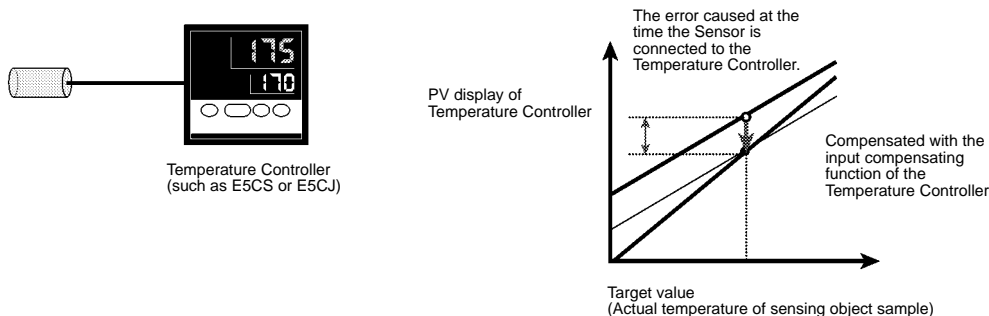

### Gain and Offset Compensation with Two-point Compensating Function

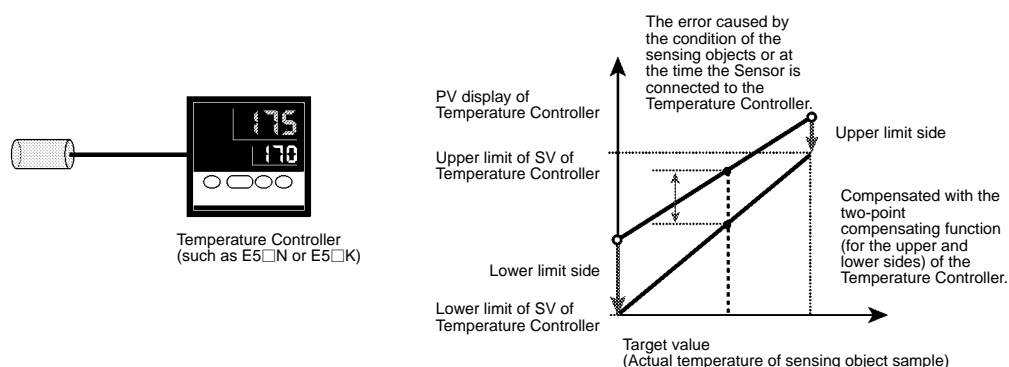

### How to Use the ES1A-J Cooling Jacket

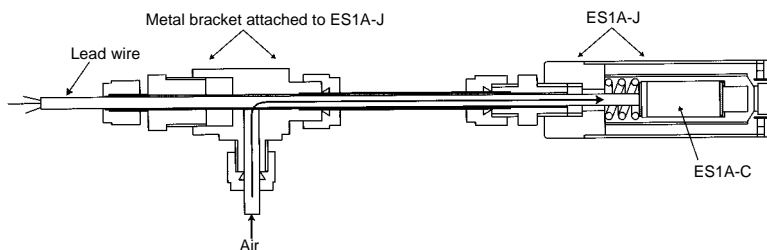

**Note:** OMRON's Multi-point Temperature Controller cannot be used.

## ■ Precautions

Refer to the *ES1A Non-contact Temperature Sensor Operation Manual*, which will be released soon, for precautions in detail.

**ALL DIMENSIONS SHOWN ARE IN MILLIMETERS.**  
 To convert millimeters into inches, multiply by 0.03937. To convert grams into ounces, multiply by 0.03527.

Cat. No. H106-E1-1 In the interest of product improvement, specifications are subject to change without notice.

## OMRON Corporation

Supervisory Control Devices Division  
 28th Fl., Crystal Tower Bldg.,  
 1-2-27, Shiromi, Chuo-ku,  
 Osaka 540-6028 Japan  
 Phone: (81)6-949-6035 Fax: (81)6-949-6069

Printed in Japan  
 1098-3M (1098) Ⓐ