

### DIN-sized (96 x 96-mm) Temperature Controller Featuring Advanced PID Control and Heater Burnout Detection

- Advanced PID control with two degrees of freedom to improve stability and response speed.
- Heater burnout alarm built in.
- Select from seven temperature sensors and a total of 14 temperature ranges (seven Fahrenheit and seven Celsius).
- High accuracy: 0.3% of set value.
- Models with communications capabilities also available.



## Ordering Information

The model numbers for the basic Temperature Controller, its five Control Output Units, and two Current Transformers are given below. Be sure to specify an Control Output Unit and Current Transformer when ordering.

Example: E5AX-AH, Relay Output Unit E53-R, Current Transformer E54-CT1

You can also order the Temperature Controller (E5AX-AHM) and a Communications Board separately. Select the desired Communications Board from the table below.

Example: E5AX-AHM, Output Unit E53-S, Communications Board E53-X01, Current Transformer E54-CT1

### ■ Temperature Controllers

Communications*	None	RS-232C	RS-422	RS-485	BCD	Transmission output** (4 to 20 mA)	Communications Board Add-on Type
<b>Model</b>	E5AX-AH	E5AX-AH01	E5AX-AH02	E5AX-AH03	E5AX-AH20	E5AX-AHF	E5AX-AHM

### ■ Control Output Units

Output	Relay output	SSR output	Voltage output (for driving SSR)		
			12 VDC, NPN	24 VDC, NPN	24 VDC, PNP
<b>Model</b>	E53-R	E53-S	E53-Q	E53-Q3	E53-Q4

### ■ Current Transformers

Hole diameter	5.8 mm	12.0 mm
<b>Model</b>	E54-CT1	E54-CT3

### ■ Communications Boards

Communications	RS-232C	RS-422	RS-485	BCD	Transmission output** (4 to 20 mA)
<b>Model</b>	E53-X01	E53-X02	E53-X03	E53-X20	E53-XF

\*For details, refer to the *E5AX Communications Manual*.

\*\*Capable of transmitting the process value or output variable, but the remote setting function by external input is not provided.

## ■ Temperature Ranges

Input (switch selectable)		Thermocouple						Temperature resistance thermometer
		K (CA) Chromel vs. almel	J/L (IC) Iron vs. constantan	T/U (CC) Copper vs. constantan	E (CRC) Chromel vs. constantan	R (PR) Platinum vs. platinum rhodium 13%	S Platinum vs. platinum rhodium 10%	PT platinum resistance thermometer (Pt100/JPt100)
Range	°C	-200 to 1,300	-100 to 850	-200 to 400	0 to 600	0 to 1,700	0 to 1,700	-99.9 to 450.0
	°F	-300 to 2,300	-100 to 1,500	-300 to 700	0 to 1,100	0 to 3,000	0 to 3,000	-99.9 to 800.0
Resolution (°C/°F) (main settings and alarm)		1						0.1

- Note:**
- Models set to display in degrees Fahrenheit (°F) can be ordered by adding “-F” to the end of the model number (example: E5AX-AH-F). The scale indication switch will then be set to °F prior to shipment from the factory.
  - For communications, Temperature Controllers with an RS-422, an RS485, or a 4- to 20-mA terminal block only are available. Order by adding a “-X” after the model number (e.g., E5AX-AH02-X).

## Specifications

### ■ Temperature Controller Ratings

Supply voltage	100 to 240 VAC, 50/60 Hz
Operating voltage range	85% to 110% of rated supply voltage
Power consumption	Approximately 10 VA (at 100 VAC) to 15 VA (at 240 VAC)
Input	Thermocouple (K/J/T/E/R/S/L/U) or temperature resistance thermometer (Pt100/JPt100) selectable
Current Transformer input	See <i>Current Transformer Ratings</i> .
Control output	See <i>Control Output Unit Ratings</i> .
Control mode	ON/OFF or PID with auto-tuning
Alarm output	Relay output: SPST-NO; 3 A, 250 VAC
Heater burnout alarm output	Relay output: SPST-NO; 1 A, 250 VAC
Setting method	Digital setting via up and down keys
Indication method	Digital indication (character heights: 15 mm and 11 mm)
Other functions	Upper and lower limits for set value Key protection Input shift Display unit selection (°C/°F) Normal and reverse output selection Watchdog timer function (Detects failures in the CPU and restores the CPU.)
Approved standards	UL (File No. E68481) CSA (File No. LR59623) SEV

### ■ Control Output Unit Ratings

Relay Output Unit	E53-R	SPDT; 5 A, 250 VAC (resistive load)
SSR Output Unit	E53-S	SPST-NO; 1 A, 75 to 250 VAC
Voltage Output Unit (for driving SSR)	E53-Q	40 mA, 12 VDC; NPN (with short-circuit protection)
	E53-Q3	20 mA, 24 VDC; NPN (with short-circuit protection)
	E53-Q4	20 mA, 24 VDC; PNP (with short-circuit protection)

**Note:** The control output is optically insulated from the internal circuits.

## ■ Current Transformer Ratings

Max. continuous heater current	50 A
Dielectric strength	1,000 VAC
Vibration	50 Hz (approx. 10G)
Weight	E54-CT1: Approx. 11.5 g; E54-CT3: Approx 50 g

## ■ Characteristics

Setting accuracy*	±0.3% of set value or ±1°C, whichever greater, ±1 digit max.
Indication accuracy	Set value coincides with the indicated value, because no relative error exists between both values.
Hysteresis	0.0° to 999.9 °C/°F (in units of 0.1°) (during ON/OFF control action)
Proportional band	0.0° to 999.9 °C/°F (in units of 0.1°)
Integral time (Reset time)	0 to 3,999 s (in units of 1 s)
Derivative time (Rate time)	0 to 3,999 s (in units of 1 s)
Alarm output setting range	Thermocouple: -999° to 9,999°C/°F Platinum resistance thermometer (Pt100): -99.9° to 999°C/°F
Control period	Pulse output: 1 to 99 s (in units of 1 s)
Sampling period	500 ms
Output refresh period	Pulse output: 500 ms Current output; 500 ms
Display refresh period	500 ms
Input shift	Thermocouple: -999° to 9,999°C/°F Platinum resistance thermometer (Pt100): -99.9° to 999.9°C/°F
Insulation resistance	20 MΩ min. (at 500 VDC) (measured with a Control Output Unit attached)
Dielectric strength	2,000 VAC 50/60 Hz for 1 minute between terminals of different polarity (measured with a Control Output Unit attached)
Vibration	Malfunction durability: 2 to 55 Hz, 2G 10 minutes each in X, Y, and Z directions Mechanical durability: 10 to 55 Hz, 0.75-mm double amplitude 2 hrs each in X, Y, and Z directions
Shock	Malfunction durability: 100 m/s <sup>2</sup> 3 times each in 6 directions Mechanical durability: 300 m/s <sup>2</sup> 3 times each in 6 directions
Ambient temperature	Operating: -10° to 55°C Storage: -25° to 65°C
Humidity	35% to 85%
Memory protection	Non-volatile memory
Enclosure ratings	Front panel: IEC standard IP50 (dust-proof) Rear case: IEC standard IP20 Terminals: IEC standard IP00
Weight	Approx. 350 g

\*The accuracy of U at temperatures from -150° to 400°C (-240°F to 700°F) is ±2°C (±3.6°F) ±1 digit. Accuracy is reduced below -150°C (-240°F). The accuracy of R and S from 0° to 200°C (0° to 400°F) is ±3°C (±5.4°F) ±1 digit.

## ■ Output Unit Characteristics

Relay unit life expectancy	Mechanical: 10,000,000 operations min.
	Electrical: 100,000 operations min.

## ■ Current Transformer Characteristics

Max. heater current	50 A, single-phase
Indication accuracy of heater current	±5% of full scale ±1 digit max.
Heater current setting range	0.1 to 49.9 A* (in units of 0.1A)
Min. detectable ON time	200 ms**

\*Heater burnout is not detected when current is set to 0.0 A; the burnout alarm will be automatically turned ON when current is set to 50.0 A.

\*\*When the control output is on for less than 200 ms, heater burnout is not detected and heater current is not measured.

## ■ Communications

Protocol		RS-232C, RS-422	RS-485	BCD	Transmission output
Transmission method		4-wire, half-duplex	2-wire, half-duplex	Data select code	4 to 20 mA DC Load: 600 Ω max. Resolution: Approx. 3,200
Synchronization method		Start-stop synchronization		—	—
Baud rate		150/300/600/1,200/2,400/4,800/9,600 bps			
Transmission code		ASCII (7-bit)			
Communica- tions	Write to Temperature Controller	Set temperature, alarm value, proportional band, integral time, differential time, heater burnout current		Set temperature, alarm value	Write disabled
	Read from Temperature Controller	Set temperature, alarm value, proportional band, integral time, differential time, output variable, set limits, process value, heater burnout current, Current Transformer input value		Set temperature, alarm value, process value, error codes etc.	Process value*, output variable

**Note:** 1. The maximum total cable length must not exceed the following limits.  
RS-422: 500 m                      RS-232C: 15 m                      RS-485: 500 m

2. A maximum of 32 Temperature Controllers can be connected to one host computer using serial communications (RS-422, RS-485).

3. \*Outputs the temperature data within the set limits.

# Dimensions

Note: All units are in millimeters.

## Temperature Controller

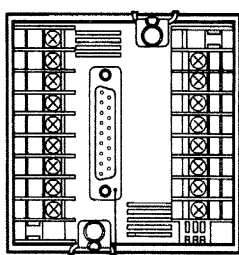
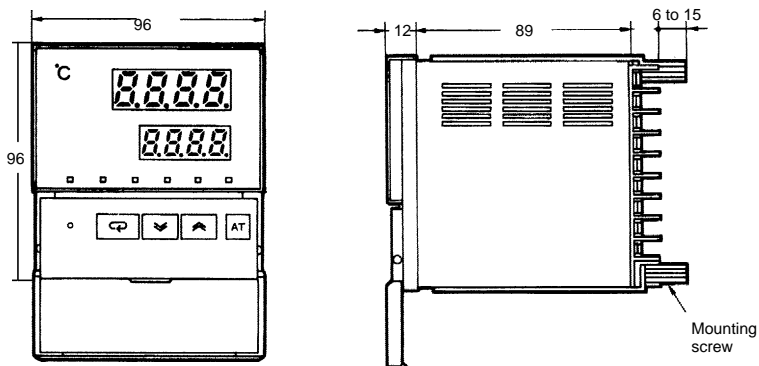

Panel Cutout

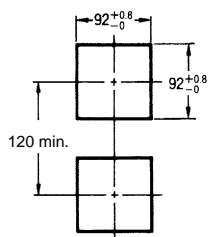

Side-by-side Mounting of N Controllers

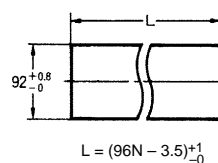

A communications connector is provided for the models with communications capabilities (a RS-232C connector (BCD) is shown).

## Current Transformer

E54-CT1

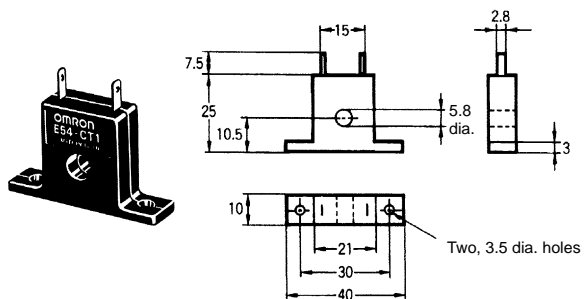

E54-CT3

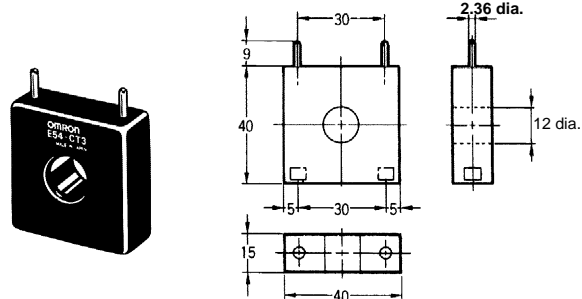

# Nomenclature

### Heater Burnout Indicator

Lights when a heater burnout is detected and stays lit until reset.

### Sensor Error Indicator

Lights when sensor malfunctions.

### Auto-tuning Indicator

Flashes on and off about every second when auto-tuning is taking place.

### Output Indicator

Lights when the control output is ON.

### Level Key

Press for 2 seconds minimum to change levels to set different groups of parameters.

### Display Key

Use this key when shifting the display to the next parameter.

### Process Value (PV) Display

Displays not only the process temperature but also indicates the parameter being displayed on the SV display and error messages.

### Set Value (SV) Display

Displays set temperature and other parameters.

### Alarm Indicator

Lights when the alarm output is ON.

### Auto-tuning Key

Press this key for 1 second or longer when PID operation has been designated to start auto-tuning. Press this key for 1 second or more during auto-tuning to stop auto-tuning.

### Up Key

When pressed, increases the set temperature or other parameters. Successively increases the value when held down.

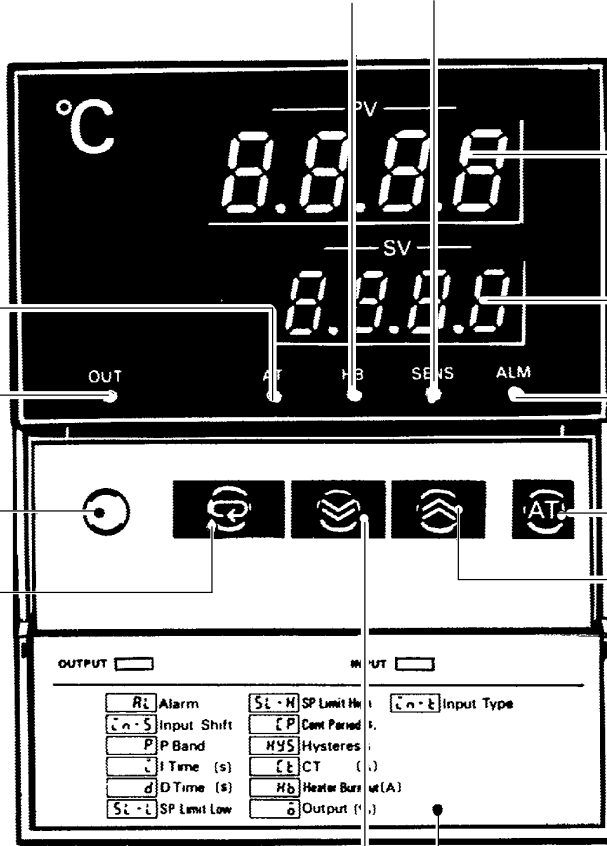

Front Cover

### Down Key

When pressed, decreases the set temperature or other parameters. Successively decreases the value when held down.

# Operation

**NOTICE:** Always turn off the power supply to the Temperature Controller before changing any switch settings.

## ■ Accessing Switches and Selectors

Before supplying power to the Temperature Controller, the selectors and switches shown below must be set to specify the temperature sensor, functions, and alarm mode. The Temperature Controller must be equipped with one of the five Control Output Units. The Control Output Unit must be ordered separately.

1. Remove the internal mechanism from the housing. Lift the internal mechanism while pressing the hook at the bottom of the front panel.

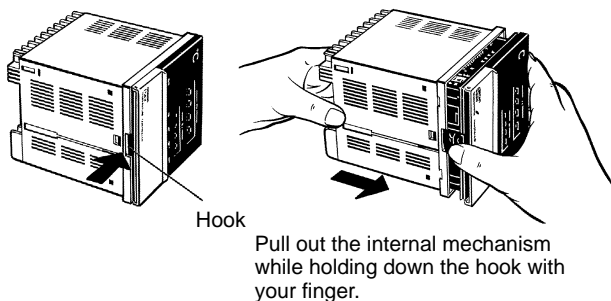

2. Connect a Control Output Unit to the vacant socket on one of the printed circuit boards (see the figure below).

Mount the Control Output Unit with this mark facing the direction indicated by the arrow.

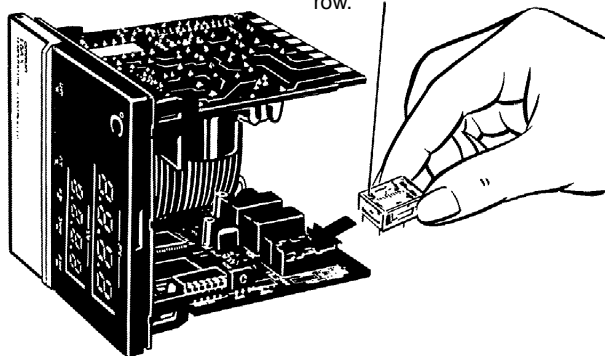

To remove a Control Output Unit, push it up with the tip of a flat-bladed screwdriver as illustrated below.

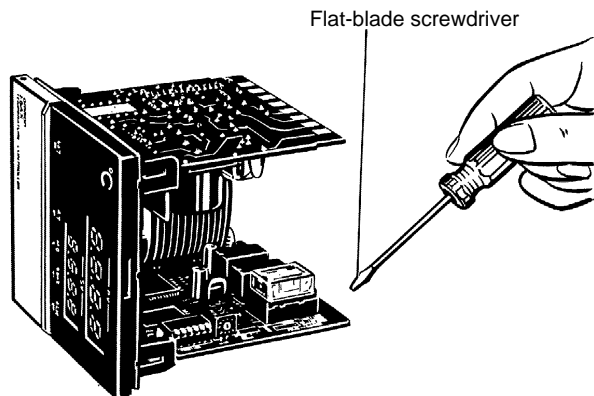

3. Three internal switches must be set: the temperature sensor selector, the operating mode selector, and the alarm mode selector. The following figure shows the locations of internal switches on the internal mechanism.

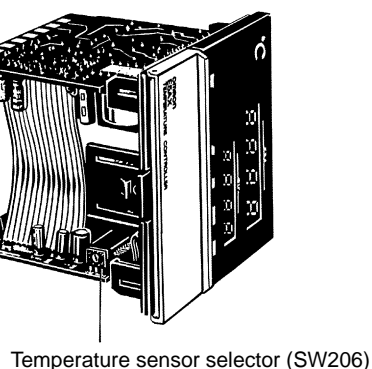
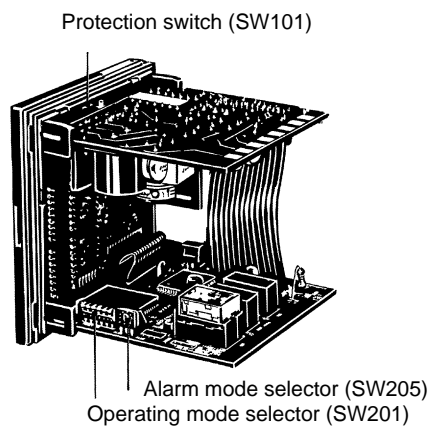

## ■ Temperature Sensor Selector (SW206, INPUT)

This selector determines the temperature sensor to be used. It is set to position 2 before shipment to designate a K-type (chromel-alumel thermocouple) temperature sensor. The following table lists the other possible settings for temperature sensors. Refer to temperature range charts under *Ordering Information* for further information.

The scale displayed (°C or °F) is set on the operating mode selector.

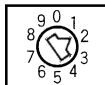

Switch setting	Temperature sensor code	Temperature range	
		°C	°F
0	R	0 to 1,700	0 to 3,000
1	S	0 to 1,700	0 to 3,000
2	K	-200 to 1,300	-300 to 2,300
3	J	-100 to 850	-100 to 1,500
4	T	-200 to 400	-300 to 700
5	E	0 to 600	0 to 1,100
6	JPt100*	-99.9 to 450.0	-99.9 to 800.0
7	Pt100*	-99.9 to 450.0	-99.9 to 800.0
8	L	-100 to 850	-100 to 1,500
9	U	-200 to 400	-300 to 700

\*JPt100: 100°C/139.16 Ω (JIS (Japan Industrial Standard)).

\*\*Pt100: 100°C/138.5 Ω (DIN, JIS).

## ■ Operating Mode Selector (SW201, FUNCTION)

This DIP switch selects the operational aspects listed in the following table.



Function	Pin number	Pin setting	Control setting
Control mode	1	ON	ON/OFF operation
		OFF	PID operation*
Control output	2	ON	Normal (cooling)
		OFF	Reverse (heating)
Input shift	3	ON	Enabled
		OFF	Disabled
Not used.**	4	Leave turned OFF.	
Indication	5	ON	°F
		OFF	°C
PID display	6	ON	Enabled
		OFF	Disabled

\*PID with 2 degrees of freedom

\*\*Always operate with pin 4 OFF. Operating with pin 4 ON could result in malfunction.



## ■ Alarm Mode Selector (SW205: ALM)

An alarm mode selector is provided. Ten alarm modes, listed in the following table, can be selected using this switch. The switch is set to position 2 before shipment, i.e., the upper-limit alarm mode.

Switch setting	Mode (SW205)		Alarm output	Setting range
	Alarm operation	Display		
0	Alarm	No display	OFF	—
1	Upper- and lower-limit alarms	]---[		Thermocouple: 0° to 9,999° Platinum resistance thermometer: 0° to 999.9°
2	Upper-limit alarm	---[		(See Note 1.) Thermocouple: -999° to 9,999°
3	Lower-limit alarm	]----		Platinum resistance thermometer: -99.9° to 999.9°
4	Inverse upper- and lower-limit range alarm	-[-]		Thermocouple: 0° to 9,999°
5	Inverse upper- and lower-limit alarm with standby sequence	3--E		Platinum resistance thermometer: 0° to 999.9°
6	Upper-limit alarm with standby sequence	---E		(See Note 1.) Thermocouple: -999° to 9,999°
7	Lower-limit alarm with standby sequence	3---		Platinum resistance thermometer: -99.9° to 999.9°
8	Event alarm	!--[		
9	Proportional alarm	P <sub>r</sub> α	See Note 2.	

**Note:** 1. If a negative value is set as X, operation will be as follows:

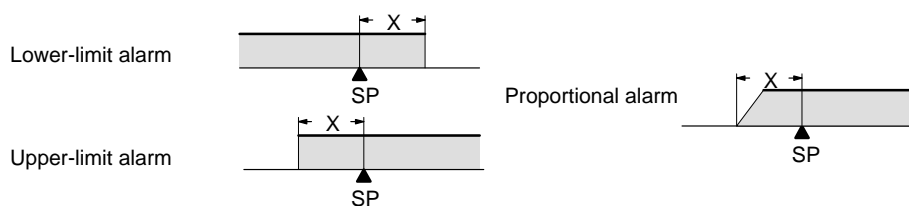

2. The alarm mode selector can be used to select the proportional alarm mode. The proportional alarm function is initiated when the temperature reaches the set alarm point (A in the figure below), which is the lower limit of a proportional band. When the temperature rises to the upper limit of the proportional band (point B in the figure), the alarm output is turned ON. This alarm function is convenient when the main setting is used for heating control, while the proportional alarm function is used for cooling control, so that heating and cooling control actions can be easily performed.

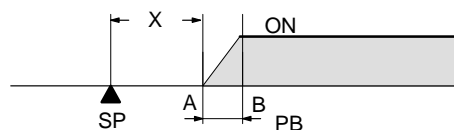

PB: proportional band (fixed to 42°C)  
Proportional period is 20 seconds.  
The operation of the alarm is not affected by pin 2 of the operating mode selector (SW201).

### Standby Sequence

Alarm functions with standby sequence suppress nuisance alarms when the controller is first powered up. As shown in the temperature charts at right, the alarm output is suppressed until the temperature exceeds the alarm band or alarm limit one time.

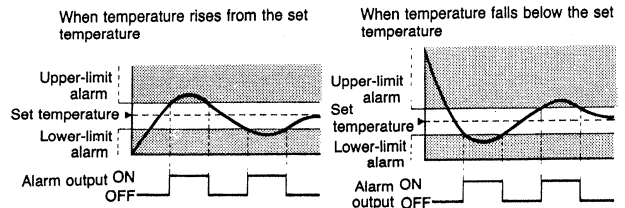

### Protection Switch (SW101, PROTECT)

When the protection switch is set to the ON position, the level key, up and down keys, and auto-tuning key will not operated. In effect, the Temperature Controller is write-protected and the set values (such as the alarm value) can be read out only.

### Inputting Parameters

The Temperature Controller has three indication levels, 0, 1, and 2, in which only specific parameters can be set. Level 0 is the default and is automatically entered during power up. To change the mode to manipulate a different group of parameters, hold down the level key for 2 seconds or more. The indication level mode changes as shown below.

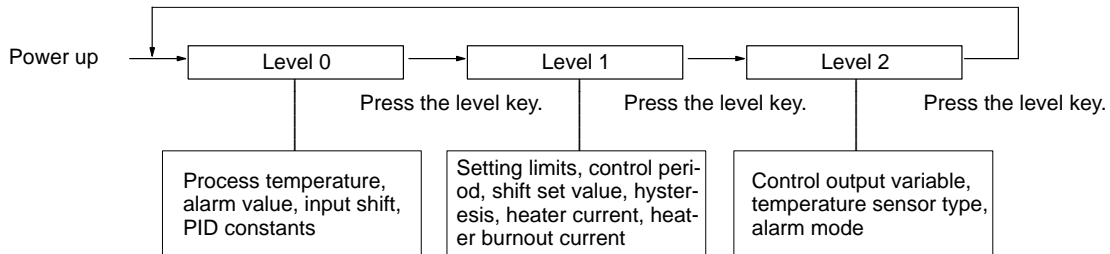

### Level 0

In this mode, parameters such as the alarm values, PID constants, and input shift values can be set or changed. When these parameters are being set or changed, the new values are displayed on the SV display. The parameter to be manipulated is selected by pressing the display key the required number of times. Note that the PID constants are displayed only when pin 1 on the operating mode selector DIP switch (SW201) is set to the OFF position and pin 6 to the ON position. (The flow chart shown below assumes the settings are as preset at the factory.)

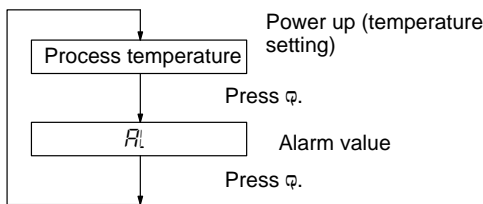

After  $R_L$  has been displayed, press the display key again. Then the PID constants can be manually set or changed, provided pin 6 on the internal operating mode selector (SW201) has been set to the ON position. The message displayed on the PV display changes as shown below each time the display key is pressed.

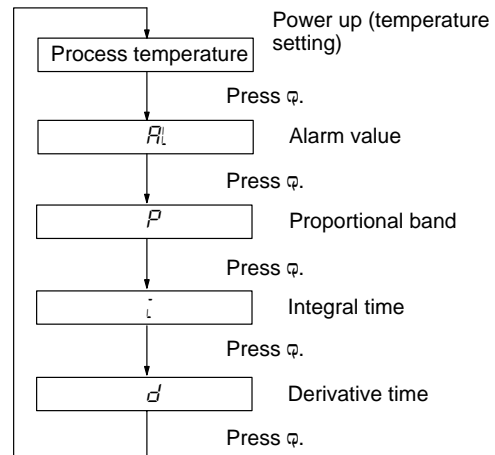

**Alarm:**  $R_L$ 

When  $R_L$  is displayed on the PV display, the alarm value for alarm output can be set on the SV display. When the temperature exceeds or falls below the set alarm value, the corresponding alarm output is produced and the ALM indicator on the front panel lights. Usually, the alarm value is set as a deviation from the set temperature (set point), but it can also be set as an absolute value when the event alarm mode is selected. Set the alarm value by using the up or down key while  $R_L$  is displayed. The message is not displayed if the alarm mode selector is set to position 0.

**Proportional Band:**  $P$ 

While  $P$  is displayed on the PV display, the proportional band (P constant) can be changed using the up or down key. The new value will be displayed on the SV display. The P constant can be set in a range from 0.0° to 999.9°C/°F in units of 0.1°C/°F. The factory setting is 40.0°C/°F.

**Integral Time (Reset Time):**  $I$ 

The integral time (I constant) can be changed when the character  $I$  is displayed on the PV display. Use the up or down key to change the I constant. The allowable range is from 0 to 3,999 seconds in units of 1 second. The factory setting is 240 seconds.

**Derivative Time (Rate Time):**  $d$ 

The derivative time (D constant) can be changed when the character  $d$  is displayed on the PV display. Use the up or down key to set or change the D constant. The allowable range is from 0 to 3,999 seconds in units of 1 second. The factory setting is 60 seconds.

**Input Shift:**  $i_n-5$ 

When pin 3 on the internal operating mode selector DIP switch (SW201) is set to the ON position, the input shift function can be used. This function is used to shift the temperature display from the measured value by a desired value, as illustrated by the examples in the following table:

Input shift value	Temperature measured by sensor	Displayed temperature
0 (without shift)	100°C	100°C
10 (offset by 10°C)	100°C	110°C
-10 (offset by -10°C)	100°C	90°C

This function can be used mainly for fine tuning compensation, while leaving the set temperature unaffected. Select this function by pressing the display key three times in display level 0, as follows:

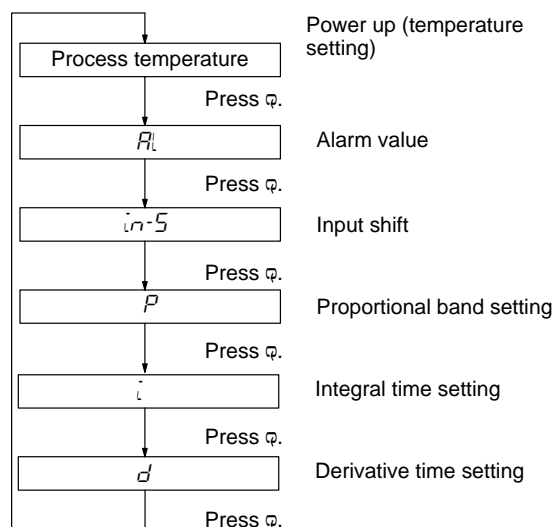

While  $i_n-5$  is displayed on the PV display, the input shift, the value by which the measured temperature is shifted and displayed, can be set and displayed on the SV display. The range in which the input shift value can be set differs depending on whether a thermocouple or temperature resistance thermometer is used as the temperature sensor. When a thermocouple is used, the allowable range is from -999 to 9,999°C/°F in units of 1°C/°F. When a temperature resistance thermometer is used, the allowable range is from -99.9 to 999.9°C/°F in units of 0.1°C/°F. The input shift function remains effective even if pin 3 on the operating mode selector DIP switch (SW201) is changed to the OFF position after the input shift value has been set. If the displayed temperature does not need to be shifted, set 0°C/°F in response to  $i_n-5$ .

## Level 1

In this level, parameters such as upper- and lower-limit values of the temperature range, control period, hysteresis, heater current, and heater burnout alarm can be set.

### 1. PID Control

When pin 1 on the operating mode selector (SW201) is set to the OFF position (PID action), the temperature setting range limit values, control period, heater current, and heater alarm burnout alarm value can be set or changed. Any of these parameters can be selected by pressing display key the required number of times as follows:

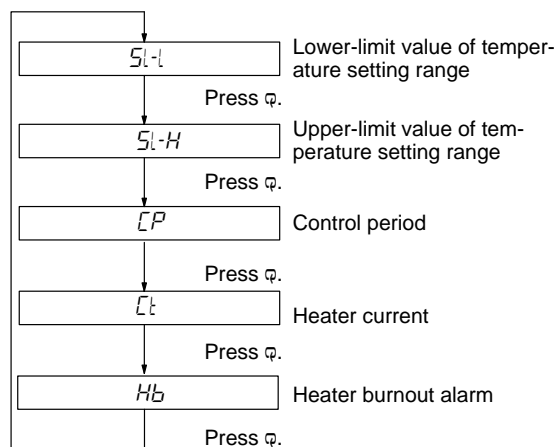

#### Lower/Upper Limits of Temperature Range: $SL-L$ , $SL-H$

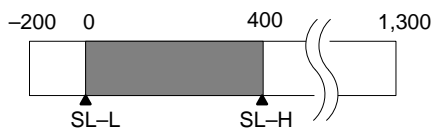

Basically, the temperature range that can be measured is determined by the temperature sensor to be used. For example, when a K-type (chromel-alumel thermocouple) temperature sensor is selected, the measurable range is from  $-200^{\circ}\text{C}$  to  $1,300^{\circ}\text{C}$ . However, this temperature range can be narrowed, say, to  $0^{\circ}\text{C}$  to  $400^{\circ}\text{C}$ . To do this, set the lower-limit value of the temperature setting range, in this case to  $0^{\circ}\text{C}$ , on the SV display by using the up or down key while  $SL-L$  is displayed on the PV display. Similarly, set the upper-limit value,  $400^{\circ}\text{C}$ , while  $SL-H$  is displayed. If the process temperature falls below the set lower-limit value or exceeds the set upper-limit value, it is displayed on the PV display provided it is within the temperature range of the temperature sensor.

#### Control Period: $CP$

To use a control period, pin 1 on the operating mode selector (SW201) must be set to the OFF position. When  $CP$  is displayed on the PV display, the control period can be set or changed in a range from 1 to 99 seconds and in units of 1 second. The factory setting is 20 seconds. When a Voltage Output Unit is used, it is recommended that the control period be set to 20 seconds or less (ideally, about 2 seconds), so that the control action can be performed more accurately.

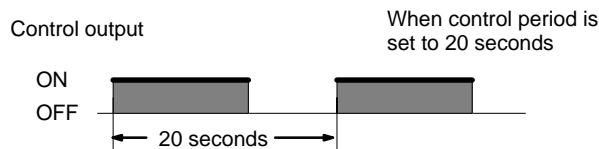

#### Heater Burnout Alarm: $Ct$ , $Hb$

Set a burnout current value to determine disconnections of the heater. Firstly, a current measured in the heater current value mode is displayed in amperes. The normal current value is the current value with the control output ON. Disconnect the heater and read the current value and obtain the set value from the following:

$$\frac{\text{Normal current value} + \text{Current value with disconnected heater}}{2}$$

Use display key and set the PV display to  $Hb$ . The difference between the normal current and the one with the disconnected heater should be 2.5 A minimum. If it is less than 2.5 A, the operation to detect the disconnection of the heater may be not stable. The value can be set with in increments of 0.1 A from 0.0 to 50.0 A.

**Note 1:** Do not allow a current of more than 50 A to flow in the Controller; the maximum continuous heater current is 50 A.

**2:** Set the value to 0.0 A if the heater burnout alarm is not used, in which case the alarm will not function at all.

#### Heater Burnout Alarm and Sensor Abnormality Alarm

Alarm	Heater burnout alarm	Sensor abnormality alarm
Output ON	Alarm output turns ON when heater burnout is detected.	Alarm output turns ON when sensor abnormality is detected.
Output terminal	Terminal output is ON when either alarm is ON.	
Output display monitor	$Hb$ on front panel is lit.	$SEr5$ on front panel is lit.
Output retention function	Yes	No
Output reset	Set heater burnout alarm value to 0.0 A or switch power OFF and then turn on power.	Output is OFF when sensor abnormal condition is solved
Influence on control output/alarm output	None	Control output: OFF; Alarm output: ON (proportional alarm output is OFF)



## Level 2

In level 2 the control output variable, temperature sensor, and modes for alarm output can be monitored. Note that level 2 is a monitoring level only and thus no parameter can be changed. When the level key is pressed for more than 2 seconds after power up,  $S\text{-}L$  is displayed on the PV display. After this message has been displayed, holding down the Level key again for 2 seconds or more causes  $\bar{o}$  to be displayed on the PV display. When this message has been displayed, the control output variable, selected temperature sensor, and alarm modes can be monitored each time the display key is pressed, as follows:

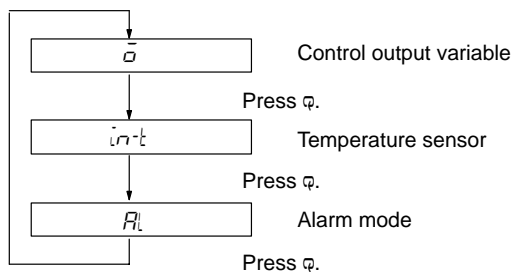

### Control Output Variable: $\bar{o}$

When the Temperature Controller enters level 2, the control output amount is displayed on the SV display in a range of 0.0% to 100.0%.

### Temperature Sensor: $i\text{-}n\text{-}t$

When  $i\text{-}n\text{-}t$  is displayed on the PV display, a message identifying the selected temperature sensor, i.e., the present setting of the temperature sensor selector (SW206), is displayed on the SV display. The following table shows the messages that may be displayed:

Display	Sensor
$r\ P_r$	R
$S\ P_r$	S
$K\ [R]$	K
$J\ [C]$	J
$t\ [C]$	T
$E\ [r]$	E
$JPt$	JPt100*
$Pt$	Pt100**
$L\ [C]$	L
$U\ [C]$	U

\*Meets JIS 1981.

\*\*Meets JIS 1989, DIN.

### AL (Alarm Mode): $Al$

While  $Al$  is displayed on the PV display in level 2, a message identifying the mode for alarm output or the present setting of the corresponding alarm mode selector (SW205) is displayed on the SV display. The following table shows the possible messages that may appear on the SV display.

Display	Alarm mode
No display	No alarm
$]--[$	Upper- and lower-limit alarms
$---[$	Upper-limit alarm
$]---$	Lower-limit alarm
$-[]-$	Inverse upper- and lower-limit alarm
$}\text{-}E$	Upper- and lower-limit alarms with standby sequence
$---E$	Upper-limit alarm with standby sequence
$}\text{-}$	Lower-limit alarm with standby sequence
$l\text{-}[$	Event alarm
$P_r\bar{o}$	Proportional alarm

### ■ Beginning Control Operation

Temperature control is begun for the set values as soon as the power is turned on, and temperature control is carried out according to the parameters that have been input. To operate the Temperature Controller after all the parameters are input, turn the power off once and then on again.

### Auto-tuning

When the auto-tuning key is pressed for 1 second or more, the Temperature Controller automatically starts tuning the PID constants. While auto-tuning is taking place, the auto-tuning indicator on the front panel will flash. The Temperature Controller executes control based on the set PID constants (factory set to P = 40°C, I = 240 seconds, and D = 60 seconds) until the temperature of the controlled system reaches the set temperature. After that, the Temperature Controller automatically adjusts the PID constants using the limit cycle method. After the automatic tuning of the PID constants has been completed, the auto-tuning display goes out.

Auto-tuning can be carried out regardless of whether the Temperature Controller is performing reverse (heating) or normal (cooling) operation. To stop auto-tuning, hold down the auto-tuning key again

for 1 second or more. Automatic tuning can be executed at any time: on power up, while the temperature is rising, and after the control action has stabilized.

### Limit Cycle Method

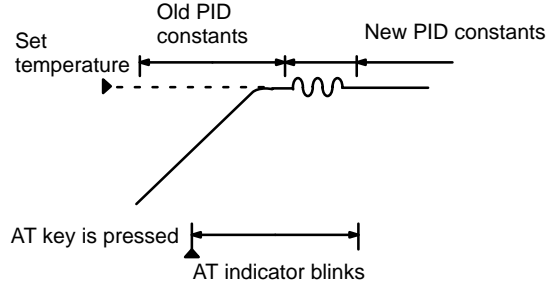

Limit cycle method:

The optimum PID constants are calculated by this method by varying the control output variable and generating external oscillation.

### ■ Advanced PID Control

Advanced PID control with two degrees of freedom adds a feed-forward (FF) loop to the conventional PID controller. Whereas the conventional PID controller responds to disturbance (d) to quickly achieve stability, it overshoots the target because it lacks sufficient control, as shown below.

This is prevented in advanced PID control because the feed-forward loop is not affected by disturbance. Here, the feed-forward loop operates from the target value (r) to achieve fast response without overshooting.

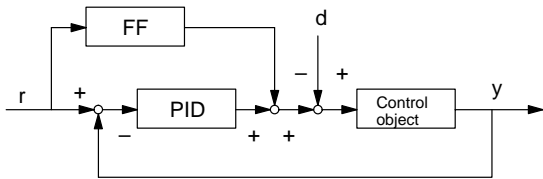

Normal PID operation	If response to target value improves, response to external disturbances degrades.
	If response to external disturbances value improves, response to target value degrades.
E5AX-H	Excellent response to both target value and external disturbances.

## Error Messages

The Temperature Controller is provided with self-diagnostic functions, and will display the following error messages on the PV display in case of an error.

Message	Cause	Control output	Alarm output
FFFF	Input temperature has risen beyond the upper limit of the temperature range by more than 20°C	OFF during reverse (heating) operation On during normal (cooling) operation	Sends alarm signal in accordance with the set alarm mode.*
----	Input temperature has fallen below the lower limit of the temperature range by more than 20°C.	On during reverse (heating) operation OFF during normal (cooling) operation	Sends alarm signal in accordance with the set alarm mode.*
S.Err (flashes)	The thermocouple has burned out or short-circuit bar has been removed. The platinum resistance thermometer has burned out or A and B have been short-circuited.	OFF	Sends alarm signal in accordance with the set alarm mode. Proportional alarm output is OFF, however.
E111 (flashes) E333 (flashes)	Memory failure (E111) or A/D converter failure (E333) has occurred. Temperature Controller must be repaired if recovery is not made by turning power off once and on again.	OFF	OFF

\*When a J thermocouple is used, however, this error message is not displayed until the temperature has risen above the set temperature range by more than 70°C.

\*\*When the temperature resistance thermometer is used, this message is displayed when the temperature has fallen to -99.9°C.

The Temperature Controller displays the following error message in case of a Current Transformer input error.

Message	Cause	Control output	Heater burnout alarm output
FFFF	CT input current is over 50.0 A	Normal	Retains condition there was before FFFF is displayed. Alarm output and sensor abnormality alarm output can function normally.

## Installation

### Wiring

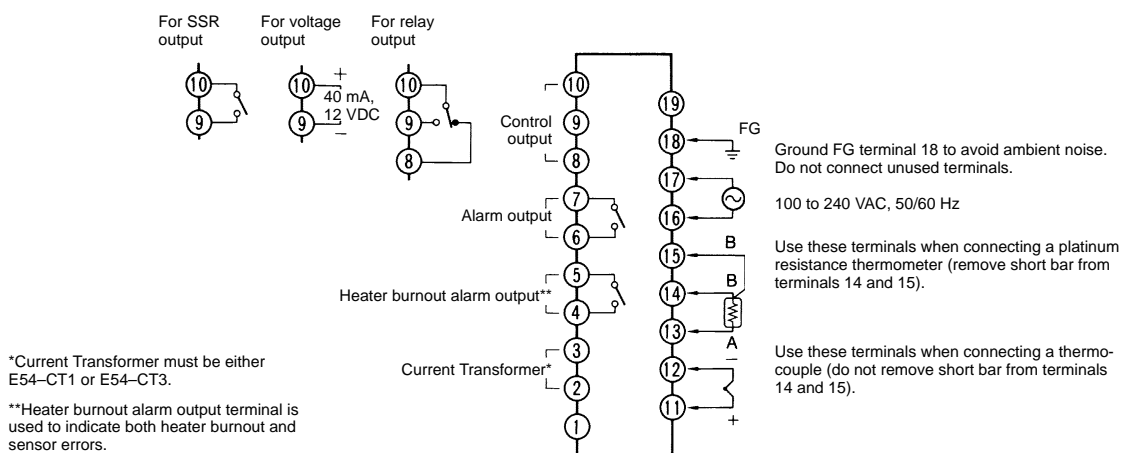

\*Current Transformer must be either E54-CT1 or E54-CT3.

\*\*Heater burnout alarm output terminal is used to indicate both heater burnout and sensor errors.



# Precautions

## Mounting

The dimensions of the Temperature Controller conform to DIN 43700. Recommended panel thickness is 1 to 8 mm. Do not install the Temperature Controller in a location exposed to excessive dust or corrosive gases. Moreover, avoid locations subject to heavy vibration or shock, water or oil spray, or high temperatures. Isolate the Temperature Controller from equipment that generates strong, high-frequency noises such as high-frequency welders. Attach the two mounting fixtures supplied with E5AX-H on the top and bottom of the Temperature Controller. Tighten the screws of the mounting fixtures with your fingers.

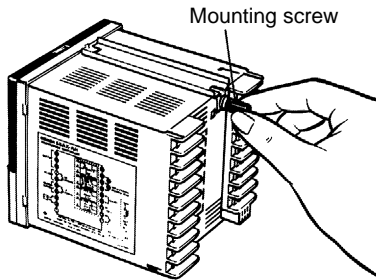

## Connection Examples

### With Solderless Terminal:

Use M3.5 solderless terminals with the Temperature Controller's M3.5 self-rising pressure plate screws.

### Solder-dipped Leads:

Strip 6 to 12 mm of the lead wires and carefully arrange the wire tips. Do not tighten the terminal screw with excessive force. The terminal block of the Temperature Controller is constructed so that the lead wires can be connected to all the terminals from the same direction.

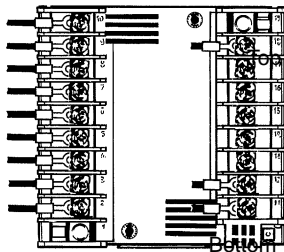

## Temperature Sensor Connection

To reduce induced noise, the lead wires connecting the temperature sensor to the Temperature Controller must be separated from the power lines and load lines.

Use the specified compensating conductors for thermocouples. When using a thermocouple as the temperature sensor, attach the short-circuit bar shown in the terminal block diagram on the housing. Use lead wires having a small resistance for temperature resistance

thermometers.

Be sure to remove the short-circuit bar from the terminals when a temperature resistance thermometer is used.

## Sequenced Circuits

Several seconds are required until the relay is turned ON after power has been supplied to the Temperature Controller. Therefore, take this time delay into consideration when designing sequenced circuits which incorporate a Temperature Controller.

## Terminal Layout Diagram on the Housing

The Temperature Controller allows an input and output device to be freely selected. Use the terminal layout diagram attached on the housing of the Temperature Controller to identify the output device mounted in the Temperature Controller, by making the diagram as follows:

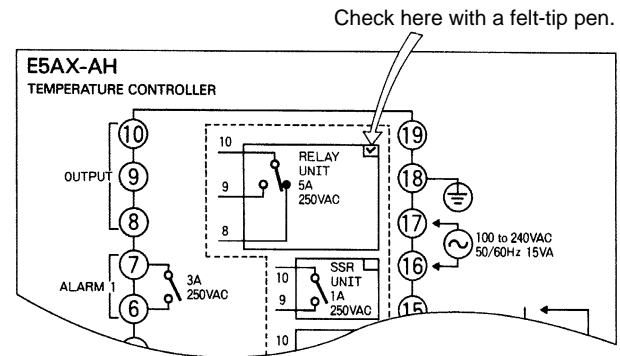

## Stickers

Stickers indicating the temperature sensor type (R, S, K, J, etc.) and Control Output Unit (R, S, and Q) are supplied with the Temperature Controller. Attach these stickers on the front panel as shown, allowing the temperature sensor and Control Output Unit mounted in the Temperature Controller can be easily discerned.

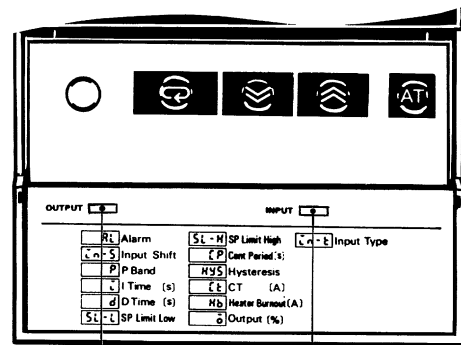

Sticker identifying Control Output Unit

Sticker identifying temperature sensor

**ALL DIMENSIONS SHOWN ARE IN MILLIMETERS.**

To convert millimeters into inches, multiply by 0.03937. To convert grams into ounces, multiply by 0.03527.

Cat. No. H48-E1-1 **In the interest of product improvement, specifications are subject to change without notice.**

---

**OMRON Corporation**

Temperature Control Devices Division  
9th Fl., Osaka Center Bldg.  
4-1-3, Kyutaro-machi, Chuo-ku,  
Osaka 541 Japan  
Phone: 06-282-2500 Fax: 06-282-2749  
Telex: 522-2484 OMRONO J

Printed in Japan  
0590-3M (0590)