

Advanced Process Digital Controllers

- Field configurable output and option boards
- 100 ms sampling (for analog input)
- Advanced PID, or fuzzy self-tuning
- Conforms to UL, CSA and CE standards
- IP66/NEMA4X front panel
- Remote set point (for E5EK and E5AK only)
- Set point ramp
- Serial communications (RS-232C, and RS-485; RS-422 for E5AK and E5EK only) and transfer output (4 to 20 mA)
- Front panel programming
- Heat/cool or standard operation
- Auto/manual and ON/OFF selections



Ordering Information

Order Control Output Boards and Option Boards separately below. Example: for a Relay Control Output, order the E53-R4R4 Output Board in addition to the E5CK-AA1-500 Process Controller. For E5AK or E5EK, order an E53-R output module.

Note: You can mount only one Output Board and one Option Board to E5EK or E5CK.

Item	Description	Part number
Standard models	Base Unit with terminal cover	E5AK-AA2-500
		E5EK-AA2-500
		E5CK-AA1-500
		E5CK-AA1-302
Position-proportional	Base Unit with terminal cover	E5AK-PRR2-500
		E5EK-PRR2-500
24 AC/DC models	Base Unit with terminal cover	E5AK-AA2-500 AC/DC 24V
		E5AK-PRR2-500 AC/DC 24V
		E5EK-AA2-500 AC/DC 24V
		E5EK-PRR2-500 AC/DC 24V
		E5CK-AA1-500 AC/DC 24V

- Note: 1. When using the heater burnout alarm function with a standard model, the Linear Output Module cannot be used for the control outputs (heat). The Digital Controller provides transfer outputs at 4 to 20 mA for the PV and other values and control outputs at 4 to 20 mA for the current outputs.
2. Order Output and Option Boards separately.
3. E5EK-PRR2/E5AK-PRR2 controllers are supplied with relay output. The relay output is not compatible with any other module.

Ordering Information Table - continued from previous page

Item	Description	Part number
Output Module (for E5AK and E5EK only)	Relay	E53-R
	SSR	E53-S
	Pulse (NPN) 12 VDC	E53-Q
	Pulse (NPN) 24 VDC	E53-Q3
	Pulse (PNP) 24 VDC	E53-Q4
	Linear (4 to 20 mA)	E53-C3
	Linear (0 to 20 mA)	E53-C3D
	Linear (0 to 10 V)	E53-V34
	Linear (0 to 5 V)	E53-V35

Note: 1. The Digital Controller uses a dedicated, high-resolution Output Module. The E53-C Current Output Module for the E5□X cannot be used with the Digital Controller.

2. If the control period is less than 5 seconds, use solid state relay or pulse voltage.

Item	Description	Part number
Output Board (for E5CK only)	Relay/Relay (See note.)	E53-R4R4
	Pulse (NPN)/Relay	E53-Q4R4
	Pulse (PNP)/Relay	E53-Q4HR4
	Pulse (NPN)/Pulse (NPN)	E53-Q4Q4
	Pulse (PNP)/Pulse (PNP)	E53-Q4HQ4H
	Linear (4 to 20 mA)/Relay	E53-C4R4
	Linear (0 to 20 mA)/Relay	E53-C4DR4
	Linear (0 to 10 V)/Relay	E53-V44R4

Note: If the control period is less than 5 seconds, use solid state relay or pulse voltage.

Item	Description	Part number
Option Board (for E5AK and E5EK only)	Communication (RS-232C)	E53-AK01
	Communication (RS-422)	E53-AK02
	Communication (RS-485)	E53-AK03
	Event input	E53-AKB
	Transfer output (4 to 20 mA)	E53-AKF

Note: 1. The E5AK allows a maximum of three Option Boards to be mounted. Refer to pages 25-26 for mounting combinations.

2. The E5EK and E5CK allows only one Option Board to be mounted.

Item	Description	Part number
Option Board (for E5CK only)	Communication (RS-232C)	E53-CK01
	Communication (RS-485)	E53-CK03
	Event input	E53-CKB
	Transfer output (4 to 20 mA)	E53-CKF

■ ACCESSORIES (ORDER SEPARATELY)

Item	Hole Diameter	Part number
Current Transformer (for E5AK and E5EK only)	5.8 mm	E54-CT1
	12.0 mm	E54-CT3

Note: CT is required when the heater burnout alarm function is used.

Item	Connectable Models	Part number
Terminal Cover	E5AK	E53-COV0809
	E5EK	E53-COV08
	E5CK	E53-COV07

■ INPUT TYPES (SELECTABLE WITH INPUT JUMPER CONNECTOR)

Platinum Resistance Thermometer (RTD's)

Input (field selectable)		JPt100	Pt100
Range	°C	-199.9 to 650.0	-199.9 to 650.0
	°F	-199.9 to 999.9	-199.9 to 999.9
Input setting number		0	1

Thermocouple

Input (field selectable) (see note)	K1	K2	J1	J2	T	E	L1	L2	U	N	R	S	B	W	PLII	
Range	°C	-200 to 1,300	0.0 to 500.0	-100 to 850	0.0 to 400.0	-199.9 to 400.0	0 to 600	-100 to 850	0.0 to 400.0	-199.9 to 400.0	-200 to 1,300	0 to 1,700	0 to 1,700	100 to 1,800	0 to 2,300	0 to 1,300
	°F	-300 to 2,300	0.0 to 900.0	-100 to 1,500	0.0 to 750.0	-199.9 to 700.0	0 to 1,100	-100 to 1,500	0.0 to 750.0	-199.9 to 700.0	-300 to 2,300	0 to 3,000	0 to 3,000	300 to 3,200	0 to 4,100	0 to 2,300
Input setting number	2	3	4	5	6	7	8	9	10	11	12	13	14	15	16	

- Note: 1. Setting number is factory-set to 2 (K1).
 2. Thermocouple W is W/Re5-26 (tungsten rhenium 5, tungsten rhenium 26).

Current/Voltage

Input (field selectable)	Current input		Voltage input		
	4 to 20 mA	0 to 20 mA	1 to 5 V2	0 to 5 V	0 to 10 V
Input setting number	17	18	19	20	21

- Note: When a current/voltage input is selected, the decimal point is fully adjustable.

Specifications

■ RATINGS

Model number		E5□K Standard		E5□K 24V AC/DC
Supply voltage		100–240VAC, 50/60 Hz		24V AC/DC, 50/60Hz
Operating voltage range		85% to 110% of rated supply voltage		85% to 110% of rated supply voltage
Power consumption		E5AK	16 VA	9VA, 6W
		E5EK	15 VA	9VA, 6W
		E5CK	10 VA (at 100 VAC) 14 VA (at 240 VAC)	6VA, 3.5W
Input	Thermocouple	K, J, T, E, L, U, N, R, S, B, W, PLII		
	Platinum resistance thermometer (RTD)	JPt100, Pt100		
	Current input	4 to 20 mA, 0 to 20 mA		
	Voltage input	1 to 5 V, 0 to 5 V, 0 to 10 V		
Mean Time Between Failure		15.4 years (135,000 hours)		
Control output (See Note 1.)	Relay	SPST, 250 VAC, 3 A (resistive load) Mechanical life expectancy: 10,000,000 operations min. Electrical life expectancy: 100,000 operations min.		
	Voltage (Pulse)	NPN	20 mA at 12/24 VDC (with short-circuit protection)	
		PNP	20 mA at 24 VDC (with short-circuit protection)	
	Linear voltage	0 to 10 VDC	Permissible load impedance: 1 kΩ min. Resolution: Approximately 2600 steps	
	Linear current	4 to 20 mA	Permissible load impedance: 500 Ω max. Resolution: Approximately 2600 steps	
0 to 20 mA		Permissible load impedance: 500 Ω max. Resolution: Approximately 2600 steps		
Auxiliary output	SPST-NO	E5AK	3 A at 250 VAC (resistive load)	
		E5EK	3 A at 250 VAC (resistive load)	
		E5CK	1A at 250 VAC (resistive load)	
Control method (See Note 2.)		ON/OFF, Advanced PID Control (with auto-tuning) or Self-tuning		
Setting method		Digital setting using front panel keys or communications features		
Indication method – 7-seg. digital display and LEDs		E5AK: PV = 15 mm, SP = 10.5 mm E5EK: PV = 14 mm, SP = 9.5 mm E5CK: PV = 12 mm, SP = 8 mm		
Potentiometer (Valve Positioning) (for E5AK and E5EK only)		100 Ω to 2.5 kΩ		
Event input	Contact input	ON	1 kΩ max.	
		OFF	100 kΩ min.	
	No-contact input	ON	residual voltage: 1.5 V max.	
		OFF	leakage current: 0.1 mA max.	
Transmission output		4 to 20 mA, permissible load impedance: 600 Ω max., resolution: Approximately 2600 steps		
Remote SP input (for E5AK and E5EK only)		Current input	4 to 20 mA (Input impedance: 150 Ω)	
Current Transformer input (for E5AK and E5EK only)		Connect only an Omron Current Transformer (E54-CT1 or E54-CT3)		
Other functions	Standard	Manual output, heating/cooling control, SP limiter, loop burnout alarm, SP ramp, MV limiter, MV change rate limiter, input digital filter, input shift, run/stop, protect functions		
	Option	Multiple SP, run/stop selection, transfer output functions, auto/manual Communications (RS-232C, RS-422, or RS-485), Loop Break Alarm, and Transfer Output.		
Standards	UL	File No.: E68481		
	CSA	File No.: LR59623		
	CE	File No.: EN50081-2; EN50082-2; IEC 1010-1		

Note: 1. All control outputs are insulated from the input circuit.

2. Fuzzy self-tuning is available only when using the Digital Controller in standard control operation with temperature input.

■ CHARACTERISTICS

Indication accuracy (See Note.)		Thermocouple: (±0.3% of indication value or ±1°C, whichever is greater) ±1 digit max. Platinum resistance thermometer: (±0.2% of indication value or ±0.8°C, whichever is greater) ±1 digit max. Analog input: ±0.2% (of indication value) ±1 digit max.
Hysteresis		0.01% to 99.99% FS (in units of 0.01% FS)
Proportional band (P)		0.1% to 999.9% FS (in units of 0.1% FS)
Integral (reset) time (I)		0 to 3,999 s (in units of 1 s)
Derivative (rate) time (D)		0 to 3,999 s (in units of 1 s)
Control period		1 to 99 s (in units of 1 s)
Manual reset value		0.0% to 100.0% (in units of 0.1%)
Alarm setting range		-1,999 to 9,999 or -199.9 or 999.9 (decimal point position dependent on input type)
Sampling period	Temperature input	250 ms scan rate
	Analog input	100 ms scan rate
Insulation resistance		200 MΩ min. (at 500 VDC)
Dielectric strength		2,000 VAC, 50/60 Hz for 1 min between terminals of different polarities
Vibration resistance	Malfunction	10 to 55 Hz, 10 m/s ² (approx. 1G) for 10 min each in X, Y, and Z directions
	Mechanical	10 to 55 Hz, 20 m/s ² (approx. 2G) for 2 hrs each in X, Y, and Z directions
Shock resistance	Malfunction	200 m/s ² min. (approx. 20G), 3 times each in 6 directions (100 m/s ² (approx. 10G) applied to the relay)
	Mechanical	300 m/s ² min. (approx. 30G), 3 times each in 6 directions
Ambient temperature	Operating	-10°C to 55°C (14°F to 131°F) with no icing; with 3-year warranty period: -10°C to 50°C (14°F to 122°F)
	Storage	-25°C to 65°C (-13°F to 149°F) with no icing
Ambient humidity	Operating	35% to 85% RH
Enclosure ratings	Front panel	NEMA 4X for indoor use (equivalent to IP66)
	Rear case	IEC standard IP20
	Terminals	IEC standard IP00
Memory protection		Non-volatile memory (number of writings: 100,000 operations)
Weight	E5AK	Approx. 450 g
	E5EK	Approx. 320 g
	Mounting bracket	Approx. 65 g
	E5CK	Approx. 170 g
	Adapter	Approx. 10 g
EMC		Emission Enclosure: EN55011 Group 1 class A Emission AC Mains: EN55011 Group 1 class A Immunity ESD: EN61000-4-2: 4 kV contact discharge (level 2) 8 kV air discharge (level 3) Immunity RF-interference: ENV50140: 10 V/m (amplitude modulated, 80 MHz to 1 GHz) (level 3) 10 V/m (pulse modulated, 900 MHz) Immunity Conducted Disturbance: ENV50141: 10 V (0.15 to 80 MHz) (level 3) Immunity Burst: EN61000-4-4: 2 kV power-line (level 3) 2 kV I/O signal-line (level 4)
Standards - Approvals		UL1092, CSA22.2 No. 14, CSA22.2 No. 1010-1 Conforms to EN50081-2, EN50082-2, EN61010-1 (IEC1010-1) Conforms to VDE0106/part 100 (Finger Protection)

Note: Indication Accuracy -

Of the K1, T, and N thermocouples at a temperature of -100°C or less: ±2°C ±1 digit maximum.

Of the U, L1, and L2 thermocouples at any temperature: ±2°C ±1 digit maximum.

Of the B thermocouple at a temperature of 400°C or less: unrestricted.

Of the R and S thermocouples at a temperature of 200°C or less: ±3°C ±1 digit maximum.

Of the W thermocouple at any temperature: ±0.3% of the indicated value or ±3°C, (whichever is greater) ±1 digit maximum.

Of the PLII thermocouple at any temperature: ±0.3% or ±2°C, whichever is greater ±1 digit maximum.

■ OPTION BOARD RATINGS AND CHARACTERISTICS

Event inputs		Contact input: ON: 1 k Ω max., OFF: 100 k Ω min. No-contact input: ON: residual voltage 1.5 V max., OFF: leakage current 0.1 mA max.
Communications	Interface	RS-232C and RS-485; RS-422 for E5AK and E5EK only
	Transmission method	Half-duplex
	Synchronization method	Start-stop synchronization (asynchronous method)
	Baud rate	1.2/2.4/4.8/9.6/19.2 kbps
Transfer output		4 to 20 mA: Permissible load impedance: E5AK and E5EK = 600 Ω max. E5CK = 500 Ω max. Resolution: E5AK and E5EK = approx. 2,600 steps E5CK = approx. 2,600 steps
		RS-232C Peer-to-peer only; maximum cable length = 15 m (49.2 feet) RS-422 and RS-485 32 controller maximum to host computer; maximum cable length = 500 m (1640 feet)

■ CURRENT TRANSFORMER RATINGS

Max. continuous heater current	50 Amps
Dielectric strength	1,000 VAC (for 1 min)
Vibration resistance	50 Hz, 98 m/s ² (10G)
Weight	E54-CT1: approx. 11.5 g; E54-CT3: approx. 50 g
Accessories (E54-CT3 only)	Armature: 2; Plug: 2

■ HEATER BURNOUT ALARM

Max. heater current	Single-phase 50 A VAC (See Note 1.)
Heater current value display accuracy	$\pm 5\%$ FS ± 1 digit max.
Heater burnout alarm setting range	0.1 to 49.9 A (in units of 0.1 A) (See Note 2.)
Min. detection ON time	190 ms (See Note 3.)

- Note: 1. Use the K2CU-F□□A-□GS (with gate input terminals) for the detection of three-phase heater burnout.
2. The heater burnout alarm is always OFF if the alarm is set to 0.0 A and always ON if the alarm is set to 50.0 A.
3. No heater burnout detection or heater current value measurement is possible if the control output (heat) is ON for less than 190 ms.

Nomenclature

■ E5AK

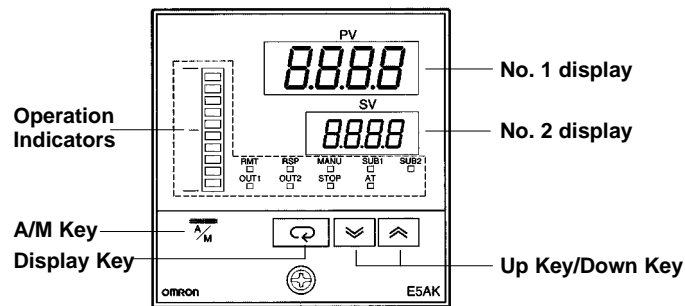

■ E5EK

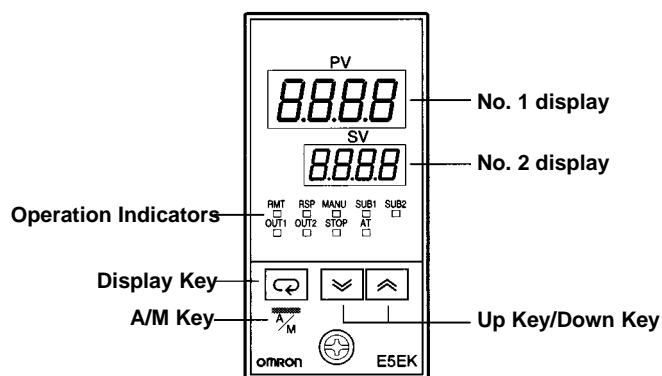

■ E5CK

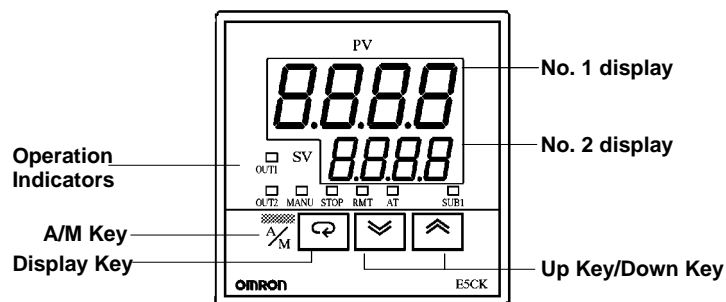

■ E5CK-302

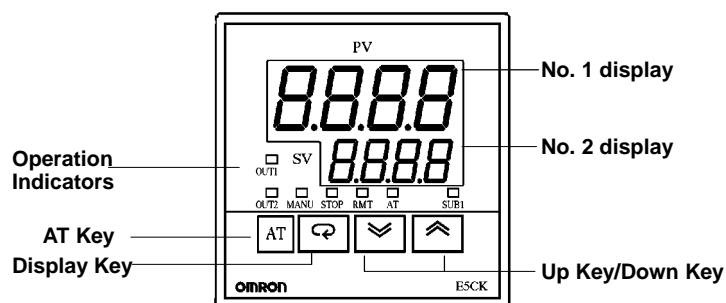

Operation Indicators

- **OUT1**
Lit when control output 1 turns ON.
- **OUT2**
Lit when control output 2 turns ON.
- **SUB1**
Lit when the output function assigned to auxiliary output 1 turns ON.
- **SUB2** (for E5AK and E5EK only)
Lit when the output function assigned to auxiliary output 2 turns ON.
- **MANU**
Lit when the manual operation mode is being used.
- **STOP**
Lit when control operation has been stopped.
- **RMT**
Lit during remote communications operation.
- **AT**
Flashes during auto-tuning. Auto-tuning is completed when this LED stops flashing.
- **RSP** (for E5AK and E5EK only)
Lit during remote SP operation.
- **Bar Graph** (for E5AK only)
On a standard model (E5AK-AA2), this bar graph indicates the manipulated variable (heat) in 10% increments per single segment. On a position-proportional model (E5AK-PRR2), this bar graph indicates the valve opening in 10% increments per single segment.

No. 1 Display

Displays the process value or parameter symbols.

No. 2 Display

Displays the set point, set point during SP ramp, manipulated variable, or parameter settings.

A/M Key

Press to select the auto operation or manual operation.

Up Key/Down Key

Press to increase or decrease the value on the No.2 display.

Display Key

Press quickly (for less than 1 s) to shift the display to the next parameter. When this key is pressed for 1 s or more, the menu screen will be displayed in any case.

- **AT**
Press key for automatic tuning.
- **A/M**
This feature is located in level one. (Replaced AT feature in level one).

Operation

■ OPERATING PARAMETERS

Mode Selection

Press the Display Key for 1 sec. min. to switch to modes other than the manual or protect mode.

The figure below (Menu Display) shows all modes in the order that they are displayed. Some parameters are not displayed, depending on the protect mode setting and the option boards used.

Menu Display

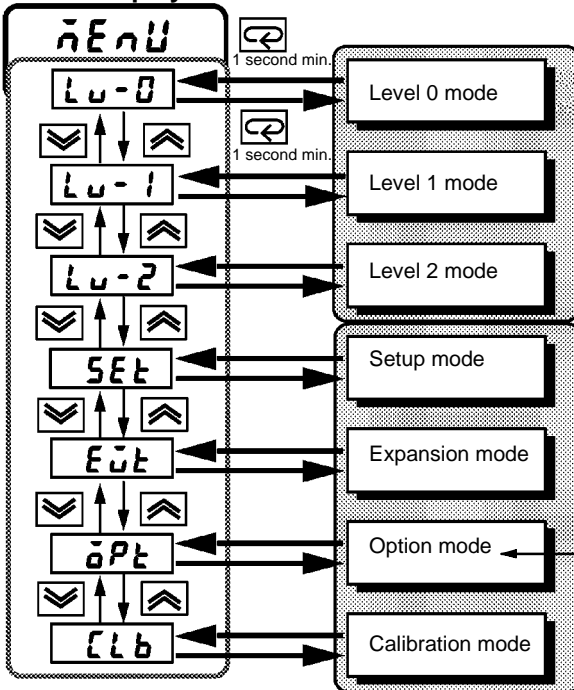

To Access *Protect Mode*

Press and hold the A/M Key and the Display Key for more than 1 second.

To Return to the Main PV/SP Display from the *Protect Mode*

Press and hold the A/M Key and the Display Key for more than 1 second.

To Access *Manual Mode*

Press and hold the A/M Key for more than 1 second.

To switch parameters **within** a mode, use the Display Key. Press the display key for less than one second to move between parameters.

Note: 1. In Level 0 mode, Level 1 mode, and Level 2 mode: The controller will maintain control of the process.

2. In Setup mode, Expansion mode, Option mode, and Calibration mode: Control of the process is not maintained. The outputs are inactive.

3. Option Mode will be accessible only when an option board is installed in the controller.

■ PARAMETERS AND MENUS - FOR SETTING THE CONTROLLER

Protect Mode	Limits use of the menu and A/M Keys. The protect function prevents unwanted modification of parameters and can also be used to prevent switching between the auto and manual operation.
Manual Mode	Sets the controller to manual operation mode. You can only manually adjust the manipulated variable (MV) in this mode.
Level 0 Mode	For normal operation. Change: the set point during operation, and start or stop Controller operation; and, (only in this mode) monitor the process value, ramp SP, and manipulated variable.
Level 1 Mode	For adjusting primary control parameters. Execute: AT (auto-tuning); set alarm values; set the control period; and, set PID parameters.
Level 2 Mode	For adjusting secondary control parameters. Set parameters for: limiting the manipulated variable and set point; switch between the remote and local modes; set the loop break alarm (LBA), alarm hysteresis, and the digital filter value of inputs.
Setup Mode	For setting the basic specifications. Set parameters for: input type, scaling, output assignments and direct/reverse operation.
Expansion Mode	For setting expanded functions. Set: ST (self-tuning), SP setting limiter. Select: advanced PID or ON/OFF control. Specify the standby sequence resetting method. Initialize parameters; and, set the time for automatic return to the monitoring display.
Option Mode	For setting option functions. Set: the communications conditions; transfer: output and event input parameters to match the type of Option Board installed in the Controller. <i>This mode will be accessible <u>only</u> when an option board is installed in the controller.</i>
Calibration Mode	For calibrating inputs and transfer output. Calibrate the selected input type. <i>Transfer output can be calibrated only when the Communications Unit (E53-CKF) has been installed in the Controller.</i>

PARAMETERS DEFINITIONS

Refer to your *User's Manual* for each parameter and the calibration mode in detail.

Level 0 Mode for E5AK and E5EK

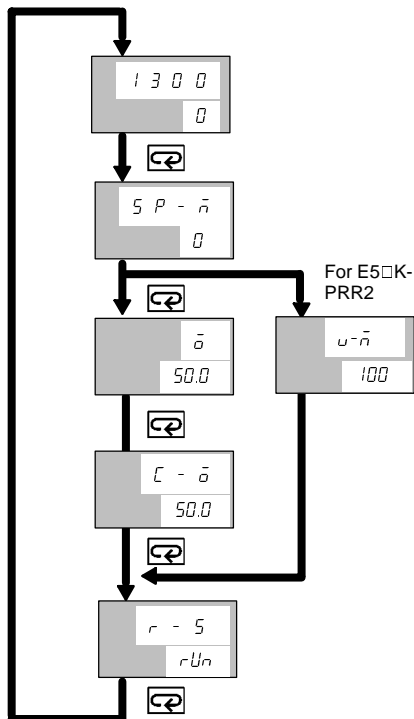

PV/SV

The process value is displayed on the No.1 display and the set point is displayed on the No.2 display. When the multi-SP function is in use, the value of the current set point (SP0 or SPD is displayed).

Set Point During SP Ramp

Monitors the set point when the SP ramp function is used.

Manipulated Variable (MV) Monitor for Heat

Monitors the manipulated variable (MV) for the heating output.

Valve Opening Monitor

Displays the valve position in percentage format.
Open = 100%
Closed = 0%

Manipulated Variable (MV) Monitor for Cool

When the Controller is in heating and cooling control operation, use this display to monitor the manipulated variable of the cooling output.

Run/Stop

Places the controller in RUN mode or in STOP mode.

Level 0 Mode for E5CK

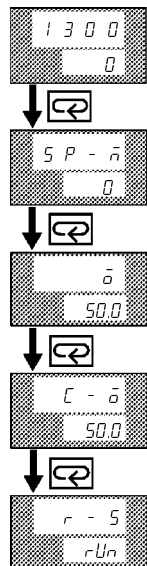

PV/SV

The process value is displayed on the No.1 display and the set point is displayed on the No.2 display. When the multi-SP function is in use, the value of the current set point (SP0 or SP1 is displayed).

Set Point During SP Ramp

Monitors the set point when the SP ramp function is used.

Manipulated Variable (MV) Monitor for Heat

Monitors the manipulated variable (MV) for the heating output.

Manipulated Variable (MV) Monitor for Cool

When the Controller is in heating and cooling control operation, use this display to monitor the manipulated variable of the cooling output.

Run/Stop

Places the controller in RUN mode or in STOP mode.

Security

Using the Security Level Table:

Any mode marked with an X is displayed in the Security Level indicated.



Example: Selecting Security Level 2:
Displays these modes: Level 0, Level 1 and Level 2 only.
Does NOT display these modes: Setup, Expansion, Option, Calibration

Mode	Set value							← Security Level
	0	1	2	3	4	5	6	
Calibration	x							
Option	x	x						
Expansion	x	x						
Setup	x	x						
Level 2	x	x	x					
Level 1	x	x	x	x				
Level 0	x	x	x	x	x	x		

↑ Lowest Security Level (first column) ↑ Highest Security Level (last column)

When the set value is **5**:
Only the **PV/SP monitor** and **set point** parameter can be used.

When the set value is **6**:
Only the **PV/SP monitor** parameter can be used.



A/M Key Protect

This invalidates the function of the A/M Key.

- To Access *Protect Mode*
Press and hold the A/M Key and the Display Key for more than 1 second.
- To Return to the Main PV/SP Display from the *Protect Mode*
Press and hold the A/M Key and the Display Key for more than 1 second.

Note: For E5CK-302 models, this is done the same way, using the AT button.

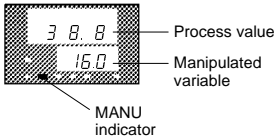

MV Manual

- To Access *Manual Mode*
Press and hold the A/M Key for more than 1 second.
Range = -105% to 105%

Level 1 Mode

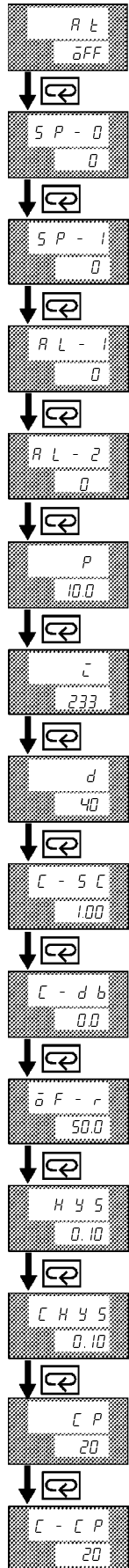
**AT Execute/Cancel**

Starts the Auto-tune function or cancels an active auto-tune. When an active auto-tune is cancelled, the original PID constants will be used again.

AT-1 = Limited MV change during Autotuning ($\pm 40\%$ max.)
 AT-2 = Full MV change during Autotuning ($\pm 100\%$ max.)

Note: E5AK and E5EK can have up to 4 set points or 4 alarms

Set Point 0

Default set point when used with multi-SP function. This set point is active when the Event input is OFF.

Note: E5AK and E5EK can have up to 4 set points or 4 alarms

Set Point 1

Used only with multi-SP function. This set point is active when the Event input is ON. This parameter is available only if an Event Input Option Board is installed.

Alarm Value 1

Available only when Control Output 2 is not used as a control output. This setting determines what the Alarm 1 set point will be.

Alarm Value 2

Available only when the alarm output function of the Controller is selected. This setting determines what the Alarm 2 set point will be. This alarm can be programmed to work on Control Output 2 or the SUB-1 output (user-selectable). Factory Default = Control Output 2.

Note: Alarm Value 3 is available only when SUB-1 or Control Output No. 1 is selected as AL-3.

Proportional Band

Range = 0.1% to 999.9%

Integral Time

Range = 0 to 3999 seconds

Derivative Time

Range = 0 to 3999 seconds
 See Note at right.

Note: For Valve Positioning Models E5□K-PRR2, all subsequent parameters (those after Derivative Time) listed in Level 1 Mode are **not** available. See Level 1 Valve Positioning model (provided on the following page).

Cooling Coefficient

Used when the Controller is in heat/cool control. This setting describes the ratio between the heating proportional band and the cooling proportional band.

$$C - SC = \frac{\text{cooling P band}}{\text{heating P band}}$$

Dead Band

Used when the Controller is in heating and cooling control. This setting determines the amount of overlap or dead band present in a heat/cool configuration. Range = -19.99 \rightarrow 99.99. Negative values = overlap band. Positive values = Dead band.

Manual Reset Value

Available **ONLY** when the integral time parameter of the Controller in standard control is set to **0**. The Controller must be in Standard or Advanced PID control and self-tune must be set to off.

Hysteresis (Heat)

Available when the Controller is in ON/OFF control. If PID control selected, this value will not appear on the menu. Range = 0.01 to 99.99 FS. Default = 0.10.

Hysteresis (Cool)

Available when the Controller is in ON/OFF control in heating and cooling control. Range = 0.01 to 99.99 FS. Default = 0.10.

Control Period (Heat)

Available only when the Controller has a relay or voltage output, or is in advanced PID control. Range = 1 to 99 s. Default = 20 s.

Control Period (Cool)

Available when the Controller has a relay or voltage output, or is in advanced PID control in heating and cooling control. Range = 1 to 99 s. Default = 20 s.

Note: This level 1 Mode ends here for the E5CK models only. For all other E5□K models in this data sheet, continue with the next page.

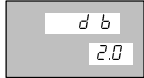
Level 1 Valve Positioning Model (for E5AK and E5EK only)**Position Proportional Dead Band**

For valve positioning units only.
Used to adjust the dead band for a valve; displayed in percentage format.
Range = 0.1-10
Default = 2.0

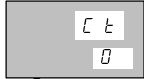
**Heater Current Monitor**

Available when the heater burnout alarm is assigned.

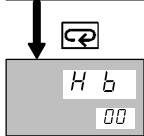
**Heater Burnout Detection**

Available when the heater burnout alarm is assigned.
Activates the Heater Burnout Alarm when the heater current falls below the set value.
Range = 0.0-50.0A
Default = 0.0

Level 2 Mode

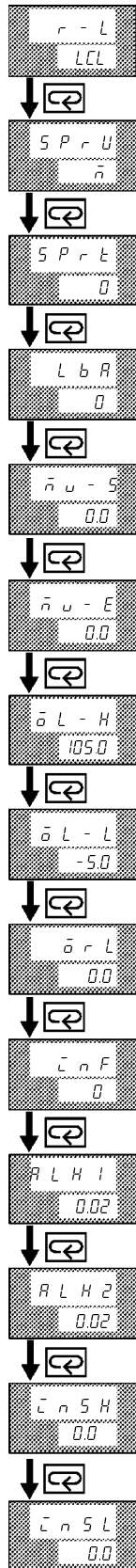
**Remote/Local**

Used for the communications function. Only accessible when communication option boards are installed. Determines whether the user will program the unit by the key pads on the face plate (local), by a computer, or PLC (remote).
Default = local.

SP Ramp Time Unit

Determines what unit of time to use on a set point ramp: minutes or hours. Self-tune must be set to OFF.
Default = minutes.

SP Ramp Set Value

Determines the maximum allowable degrees of change per Time Unit.
Example: SP Ramp Time Unit = minute SP0 = 100°F
 SP Ramp Set Value = 10° SP1 = 150°F
It will take 5 minutes to ramp up to 150°F from 100°F.
Default = 0.

LBA Detection Time

Available only when the LBA (loop break alarm) function of the Controller is selected. This parameter is automatically set by Auto-tuning. Determines how long it will take the controller to detect a loop break.
Range = 0 - 9999 sec.
Default = 0

Manipulated Variable (MV) at Stop

Determines what percentage of Manipulated Variable (MV) will be when control has been stopped.
Default = 0%
Range = -5 to 105% for standard control; -105 to 105% for heat/cool control.

MV at PV Error

Determines what percentage of Manipulated Variable (MV) will be when an input error has been detected.
Default = 0%
Range = -5 to 105% for standard control; -105 to 105% for heat/cool control.

MV Upper Limit

Stops the MV from going higher than the set value. Default = 105%

MV Lower Limit

Stops the MV from going lower than the set value.
Default (heat only) = -5%
Default (heat/cool) = -105%
Default (cool only) = -105%

MV Change Rate Limit

Limits how fast the MV can change in % of FS per second.
Default = 0%
Range = 0 - 100%

Input Digital Filter

Sets the time constant for the digital filter.
Range = 0 to 9999 sec.
Default = 0

Alarm 1 Hysteresis

Available only when the Controller has an alarm output.
Range = 0 to 9999 sec.
Default = 0.2

Alarm 2 Hysteresis

Available only when the Controller has an alarm output.
Range = 0 to 9999 sec.
Default = 0.2

Alarm 3 Hysteresis (Note: An example of this display is not shown here.)

Available only when the Controller has an alarm output.
Range = 0 to 9999 sec.
Default = 0.2

Input Shift Upper Limit

Available if the input type connected to the Controller is a thermocouple or platinum RTD.
Range = -199.9 to 999.9 °C/°F; default = 0 to 0 °C/°F

Input Shift Lower Limit

Available if the input type connected to the Controller is a thermocouple or platinum resistance thermometer.
Range = -199.9 to 999.9 °C/°F; default = 0 to 0 °C/°F

Setup Mode

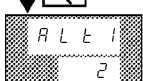
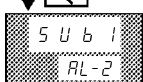
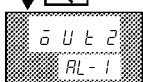
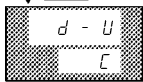
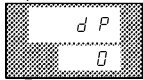
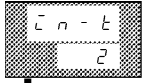
**Input Type**

Sets the input type connected to terminals 6 through 8.

Note: Set input jumper to current, voltage, or temperature setting before changing input type.

Default = 2 (K1 type thermocouple)

Scaling Upper Limit

Used if the input type connected to the Controller is an analog input (voltage or current input).

Range = 1 to 9999

Default = 100

Scaling Lower Limit

Used if the input type connected to the Controller is an analog input (voltage or current input).

Range = -1999 to -1

Default = 0

Decimal Point

Used only if the input type connected to the Controller is an analog input (voltage or current input).

Range = 0 to 3

Default = 0

°C/°F Selection

Used if the input type connected to the Controller is a temperature input (thermocouple or platinum resistance thermometer).

Default = °C

Parameter Initialize

Returns the controller to Factory Default Settings.

Control Output 1 Assignment

Assigns the Controller to have one of the following output functions: heating control, cooling control, alarm 1, alarm 2, alarm 3, and LBA (loop break alarm).

Default = heat

Control Output 2 Assignment

Assigns the Controller to have one of the following output functions: heating control, cooling control, alarm 1, alarm 2, alarm 3, and LBA (loop break alarm).

Default = Alarm 1

Auxiliary Output 1 Assignment

Enables the Controller to have one of the following outputs: alarm 1, alarm 2, alarm 3, LBA (loop break alarm)

Default = Alarm 2

Note: The following parameters are available only when the controller has an alarm output. (See the table on the Expansion Mode table.)

Alarm 1 Type

Provides a choice of 11 different alarm operations.

Default = 2 (See Alarm Summary Table for Alarm types available.)

Alarm 1 Open in Alarm

Synchronizes the alarm LED with the operation of the alarm. If the alarm is operating as a normally closed relay (open in alarm condition), this parameter should be set to 'Open in Alarm'. If the alarm is operating as a normally open relay (close in alarm condition), this parameter should be set to 'Close in Alarm'.

Alarm 2 Type

Provides a choice of 11 different alarm operations.

Default = 2 (See Alarm Summary Table for Alarm types available.)

Alarm 3 Type Note: An example of this display is not shown here.

OPEN W/Alarm

Alarm 2 Open in Alarm

Synchronizes the alarm LED with the operation of the alarm. If the alarm is operating as a normally closed relay (open in alarm condition), this parameter should be set to 'Open in Alarm'. If the alarm is operating as a normally open relay (close in alarm condition), this parameter should be set to 'Close in Alarm'.

Direct/Reverse Operation

Choose between direct (cooling) or reverse (heating) control action.

Default = reverse (heating).

Direct (cooling) = MV increases with decreasing PV.

Reverse (heating) = MV increases with increasing PV.

Selecting a Control Method

When selecting a control method, refer to the following table for correct parameter setting.

Control method	Control output 1 assignment	Control output 2 assignment	Operation
Heat	Control output (heat)	---	Reverse
Cool	Control output (heat)	---	Direct
Heat/Cool	Control output (heat)	Control output (cool)	Reverse
Heat/Cool	Control output (cool)	Control output (heat)	Direct

■ CLOSE IN ALARM/OPEN IN ALARM

If the alarm is operating as a normally closed relay (open in alarm condition), this parameter should be set to 'Open in Alarm'. If the alarm is operating as a normally open relay (close in alarm condition), this parameter should be set to 'Close in Alarm'.

Condition	Alarm	Output LED
Close in alarm (N.O.)	ON	Lit
	OFF	Not lit
Open in alarm (N.C.)	ON	Lit
	OFF	Not lit

Factory setting is "close in alarm" [\bar{o}].

Expansion Mode

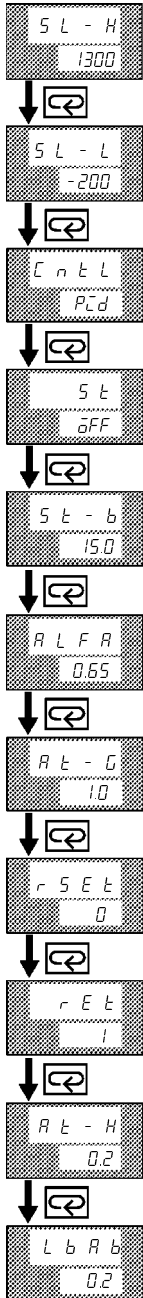
**SP Setting Upper Limit**

Stops the set point from going higher than the SP setting upper limit.
Default = 1300

This setting has no effect on the input scaling values.

SP Setting Lower Limit

Stops the set point from going any lower than the SP setting lower limit
Default = -200

This setting has no effect on the input scaling values.

PID/ON/OFF

Selects the type of control method for the controller to use.
Default = PID

Adaptive Tuning (Self Tuning)

Only available if the Controller in standard control or advanced PID control has a temperature input.
Default = OFF. If ON is selected, the controller will use fuzzy logic to self tune the PID values for optimum control.
PID values will not be seen when ST (Self Tune) is on.

ST Stable Range

Only available if the Controller is in standard control or advanced PID control with the Self Tune (ST) set to ON.

 α

Only available if the Controller is in advanced PID control with the ST set to OFF.
This setting allows tailoring of the PID algorithm to emphasize control or fast response.
Default = 0.65
Fast Response = 0.0 → 0.65
Stability Emphasis = 0.65 → 1

AT Calculated Gain

Allows the controller to focus the auto-tune on increased response or more stability.
Range = 0.1 (fast response) to 10 (increase stability).
Available if the Controller is in advanced PID control with the ST set to OFF.
Default = 1.0

Alarm Standby Sequence Reset Method

Used with alarm settings to have a stand-by sequence applied to the alarm.
Default = 0

Automatic Return of Display Mode

Automatically returns the display of the controller to Level 0 PV/SP display after the set amount of time has elapsed if no buttons on the face plate have been used.
Applies only in Levels 0 through 2. Default = 0. Range = 0 to 99 sec.

AT Hysteresis

Only available if the Controller is in advanced PID control with the ST set to OFF.
Default = 0.2% FS; Range = 0.1 to 9.9% FS

LBA Detection Width

Only available only when the LBA (Loop Break Alarm) function of the Controller is selected.
Range 0.0 → 999.9% FS
Default = 0.2

Option Mode - ONLY Visible if an Option Board is Installed

E5□K

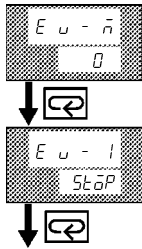

Multi-SP Function

Specifies the number of set points that will be used. Must be set to one to use SP Ramp feature.

Available for the event input function. Default = 0

Event Input Assignment 1

Available for the event input function. If multi-SP is set to 0, this parameter assigns event input function as: Run/Stop, Auto/Manual, or Protect Function. Default = Stop.

E5AK and E5EK only

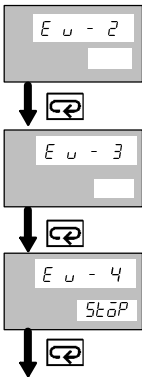

Event Input Assignment 2

Available for the event input function.

Event Input Assignment 3

Available for the event input function.

Event Input Assignment 4

Available for the event input function.

COMMUNICATIONS FUNCTION

Communications selections are ONLY available if a communications board is installed.

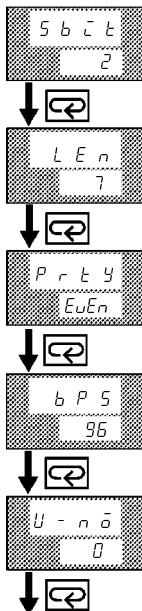

(continued on next page)

Communication Stop Bit

Displayed when the communications function is in use.

Range = 1 to 2

Default = 2

Communication Data Length

Displayed when the communications function is in use.

Range = 7 to 8

Default = 7

Communication Parity

Displayed when the communications function is in use.

Range = None, Even, Odd

Default = Even

Communication Baud Rate

Displayed when the communications function is in use.

Range = 1.2, 2.4, 4.8, 9.6, 19.2 k baud

Default = 9.6

Communication Unit No.

Displayed when the communications function is in use.

Range = 0 — 99

Default = 0

Option Mode - ONLY Visible if an Option Board is Installed, continued

TRANSFER OUTPUT SECTION

Transfer output selections are ONLY available if a transfer board is installed.



Transfer Output Type

Set when the transfer output function is in use.

Determines which function the transfer output will re-transmit as a 4-20mA signal: SP, PV, SP Ramp, MV

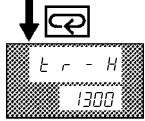

Transfer Output Upper Limit

Set when the transfer output function is in use.

Stops the transfer output from going higher than the Set Value.

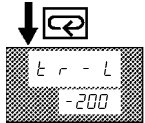

Transfer Output Lower Limit

Set when the transfer output function is in use.

Stops the transfer output from going lower than the Set Value.

REMOTE SET POINT FUNCTION

Remote set point function is available on all E5AK/E5EK models, with or without an option board installed.

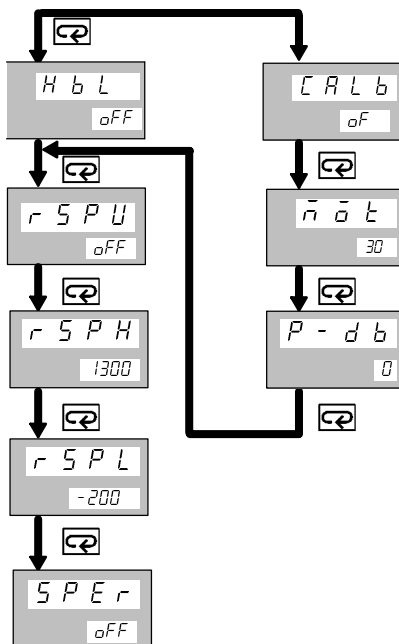

HBA Latch

Makes the heater burnout alarm remain activated when triggered. It must be reset manually.

Motor Calibration

Determines how long it takes a fully closed proportional valve to fully open.

Travel time

The amount of time it takes to determine the motor calibration parameter.

Range = 1-999 sec.

Default = 30 sec.

PV Dead Band

Determines the size of the dead band around the process variable in which the valve will take no control action.

Range = 0-9999

Default = 0

Remote SP Enable

Enables the controller to use a remote setpoint.

Default = off

Remote SP Upper Limit (Available when the remote SP is enable)

Stops the RSP from going any higher than the set value.

Default = 1300

Remote SP Lower Limit (Available when the remote SP is enable)

Stops the RSP from going any lower than the set valve.

Default = -200

SP tracking (Available when the remote SP is enable)

Allows a smooth transition between a RSP and a local SP when enabled. When on, the LSP will become the RSP that was being used immediately before switching.

■ ALARM MODE SELECTORS

Alarm outputs are available if they are allocated as outputs. Factory setting is "2: Upper-limit alarm (deviation)."

Setting number	Alarm types	Alarm output	
		When X is positive	When X is negative
1	Upper- and lower-limit alarm (deviation)		Always ON
2	Upper-limit alarm (deviation)		
3	Lower-limit alarm (deviation)		
4	Upper- and lower-limit range alarm (deviation)		Always OFF
5	Upper- and lower-limit alarm with standby sequence (deviation)		Always OFF
6	Upper-limit alarm with standby sequence (deviation)		
7	Lower-limit alarm with standby sequence (deviation)		
8	Absolute-value upper-limit alarm		
9	Absolute-value lower-limit alarm		
10	Absolute-value upper-limit alarm with standby sequence		
11	Absolute-value lower-limit alarm with standby sequence		

Note: 1. A deviation is defined as deviation from SP.

2. An absolute alarm is defined as a fixed value X with reference to 0.

3. Standby sequence is defined as having the alarm outputs inactive until SP is reached on the initial power up of the Controller. After SP has been reached, alarms will function normally.

Deviation Alarm

If the alarm mode selector is set to a number between 1 to 7, alarm values are set to the width deviated from the set point as shown in the following illustration.

Alarm value = 10°C/°F

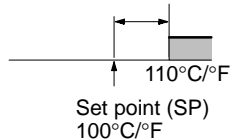

Absolute Alarm

If the alarm mode selector is set to 8 or 9, alarm values are set to the absolute value based on 0°C/°F as shown in the following illustration.

Alarm value = 328°C/°F

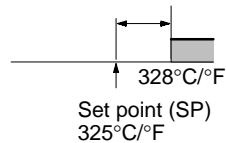

■ HOW TO USE THE ERROR DISPLAY

When an error has occurred, the No.1 display alternately indicates error codes together with the current display item. This section describes how to check error codes on the display, and the actions that must be taken to remedy the problem.

5Err

Input Error

Meaning Input is in error.

Action Check the wiring of inputs, disconnections, and shorts, and check the input type and the input type jumper connector.

Operation at Error For control output functions, output the manipulated variable matched to the setting of the "MV at PV error" parameter (level 2 mode). Alarm output functions are activated when the upper limit is exceeded.

E111

Memory Error

Meaning Internal memory operation is in error

Action First, turn the power OFF then back ON again. If the display remains the same, the E5AK/E5EK Controller must be repaired. If the display is restored to normal, the probable cause may be external noise affecting the control system. Check for external noise.

Operation at Error Control output functions turn OFF (2 mA max. at 4 to 20 mA output, and output equivalent to 0% in case of other outputs). Alarm output functions turn OFF.

E333

A/D Converter Error

Meaning Internal circuits are in error.

Action First, turn the power OFF then back ON again. If the display remains the same, the E5AK/E5EK Controller must be repaired. If the display is restored to normal, the probable cause may be external noise affecting the control system. Check for external noise.

Operation at Error Control output functions turn OFF (2 mA max. at 4 to 20 mA output, and output equivalent to 0% in case of other outputs). Alarm output functions turn OFF.

RErr

Calibration Data Error

This error is output only during temperature input and is displayed for two seconds when the power is turned ON.

Meaning Calibration data is in error.

Action Must repair.

Operation at Error Both control output functions and alarm output functions are active. However, note that the readout accuracy is not assured.

CCCC

Display Range Over

JJJJ

Meaning Though not an error, this is displayed when the process value exceeds the display range when the control range (setting range $\pm 10\%$) is larger than the display range (-1999 to 9999).

- When less than "-1999" CCCC
- When greater than "9999" JJJJ

Operation Control continues, allowing normal operation.

■ FUZZY SELF-TUNING

Fuzzy self-tuning is a function that enables the E5□K to calculate the most suitable PID constants for the control output.

Features

- The E5□K determines by itself when to perform fuzzy self-tuning.
- During fuzzy self-tuning, the E5□K does not output any signal that disturbs the temperature or output value.

Fuzzy Self-tuning Function

The fuzzy self-tuning function has three modes.

- In SRT (step response tuning) mode, the PID constants are tuned using a step response method at the time the set point is changed.
- In DT (disturbance tuning) mode, the PID constants are amended so that the controlled temperature will be within the target range set in advance when there is external disturbance.
- In HT (hunting tuning) mode, when hunting occurs, the PID constants are amended to suppress the hunting.

Note: You must turn ON the power supply to the LOAD either before or simultaneously with the start of Temperature Controller operation.

Dead time will be measured from the time the Temperature Controller starts operating. If a load, such as a heater, is turned on after the Temperature Controller is turned on, dead time longer than the actual value will be measured, and inappropriate PID constants will be obtained.

If an extremely large amount of dead time is measured, the control amount will be set to 0% for a short period of time before being returned to 100%, and the constants will then be returned. Retuning is performed only for large amounts of dead time, so be sure to follow the precaution given above when starting operation.

Startup Conditions of SRT

SRT will start if conditions 1 to 5 are satisfied when the set point is changed, or the E5□K is turned on.

1. The new set point is different from the set point used at the time SRT was last executed.
2. The difference between the new set point and the last set point is larger than the value obtained from the calculation: present proportional band value (P) x approximately 1.27+4.

Note: When the E5□K is turned on, the difference between the process value and set point is regarded as *Deviation*.

3. The temperature is stable before changing the set point, or the temperature is balanced while the E5□K is turned on before any output is obtained.
4. The set point is changed in the direction that the controlled amount increases (i.e., the control amount is in the upper direction at the time of reverse operation and in the lower direction at the time of normal operation).
5. No SRT has been executed with the current set point.

In the following cases, SRT will not be executed accurately. Therefore the E5□K must be tuned in DT or HT mode.

1. The maximum temperature slope (R) is not obtained before the process value reaches the value obtained from the calculation: present proportional band value (P) x approximately 1.27 (i.e., the maximum temperature slope (R) is not obtained before the SRT is finished). If the proportional band, obtained before SRT is finished, is larger than the previous proportional band, however, the PID constants will be renewed, so their values will be more accurate.
2. The set point is changed during SRT, and the SRT completion conditions are satisfied; and, no PID constant will be renewed.

Stable Temperature Status

If the temperature is within the stable range for a specified period, the temperature is considered *stable*.

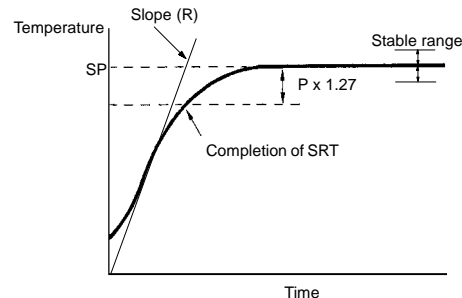

Balanced Status

If the process value is within the stable range for 60 s when there is no output, the the temperature is considered *balanced*.

Startup Conditions of DT

- DT will start if the temperature that has been stable varies due to external disturbance and the deflection of the temperature exceeds the stable range, and then the temperature becomes stable, provided that the number of maximum temperature values is less than four.
- DT will start if the set point is changed under the condition that SRT does not start and the temperature becomes stable, provided that the number of maximum temperature values is less than four.
If there are four or more maximum temperature values, HT will start.

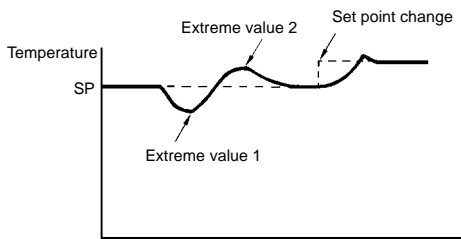

Balanced Status

If the process value is within the stable range for 60 s when there is no output, it is deemed that the the temperature is balanced.

Startup Conditions of HT

HT will be ON when there is hunting with four or more maximum temperature values (extreme values) while SRT is not being executed.

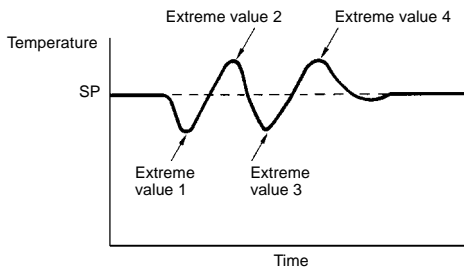

Note: In specific applications where temperature varies periodically due to disturbance, internal parameters need to be adjusted. For details, refer to your User's Manual.

Dimensions

Unit: mm (inch)

■ E5AK

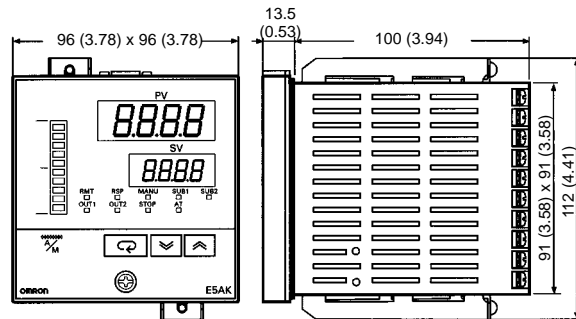

Panel Cutouts

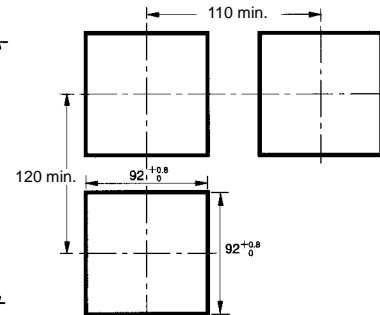

- Note: 1. Recommended panel thickness is 1 to 8 mm.
2. Maintain the specified vertical and horizontal mounting space between each Unit. Units must not be closely mounted vertically or horizontally.

■ E5EK

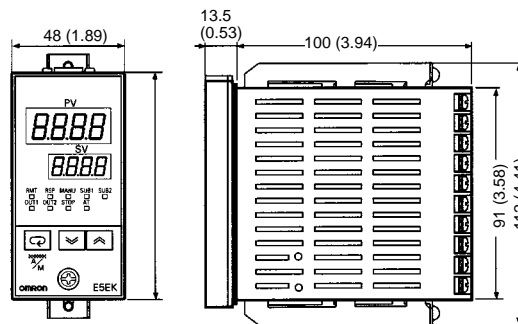
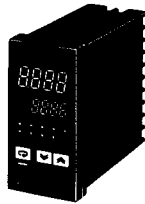

Panel Cutouts

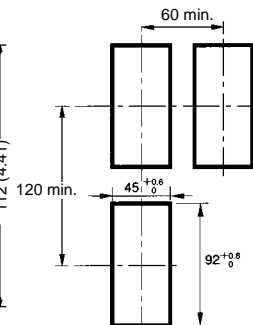

- Note: 1. Recommended panel thickness is 1 to 8 mm.
2. Maintain the specified vertical and horizontal mounting space between each Unit. Units must not be closely mounted vertically or horizontally.

■ E5CK

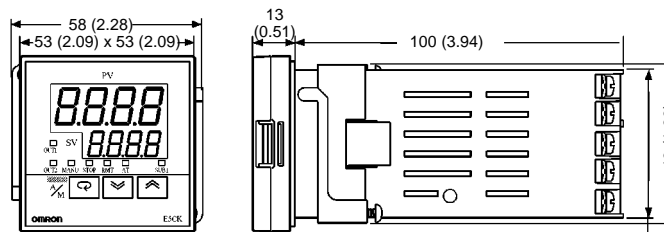

Panel Cutouts

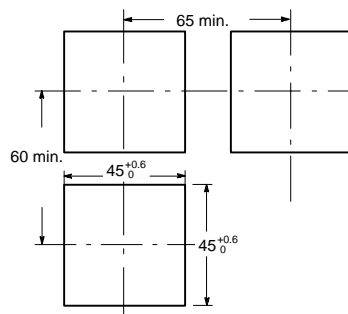

- Note: 1. Recommended panel thickness is 1 to 5 mm.
2. Maintain the specified vertical and horizontal mounting space between each Unit. Units must not be closely mounted, either vertically or horizontally.

44.8 (1.76) x 44.8 (1.76)

■ E5CK-302

The E5CK-302 model has the same dimension and cutouts as the E5CK.

■ ACCESSORIES (ORDER SEPARATELY)

Terminal Cover for E5AK

E53-COV0809

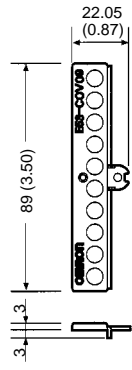
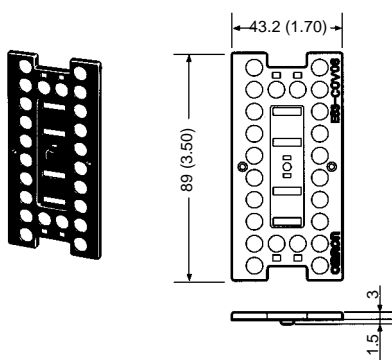

Terminal Cover for E5EK

E53-COV08

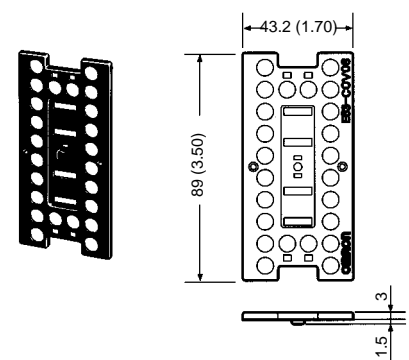

Terminal Cover for E5CK

E53-COV07

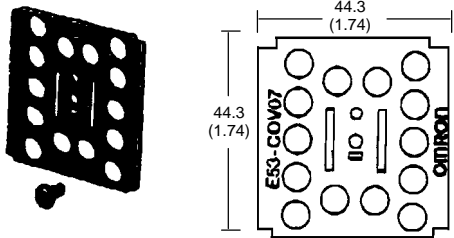

Current Transformer (E5AK and E5EK only)

E54-CT1

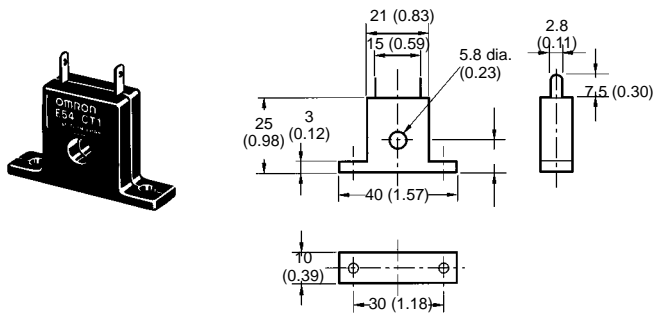

E54-CT3

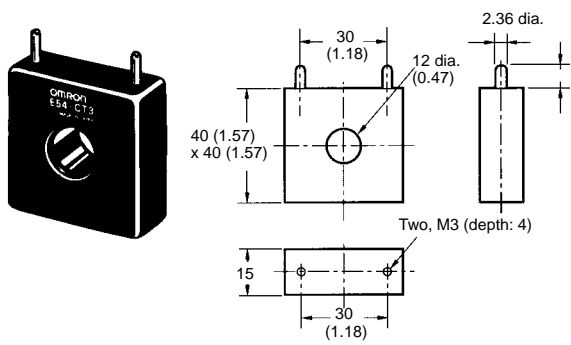

Installation

■ REMOVE CONTROLLER FROM REAR HOUSING

E5AK and E5EK

To pull out the internal mechanism from the housing, use a Phillips screwdriver matching the screw on the lower part of the front panel.

1. Turn the screw counterclockwise while pressing the hook on the upper part of the front panel.
2. Carefully pull out the internal mechanism while holding the left and right sides of the front panel.

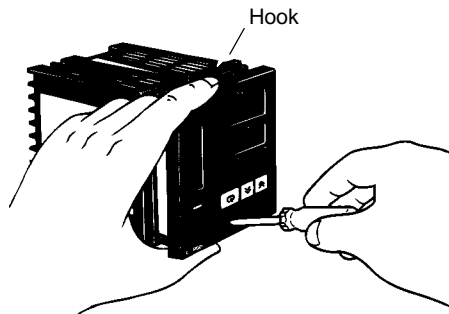

E5CK

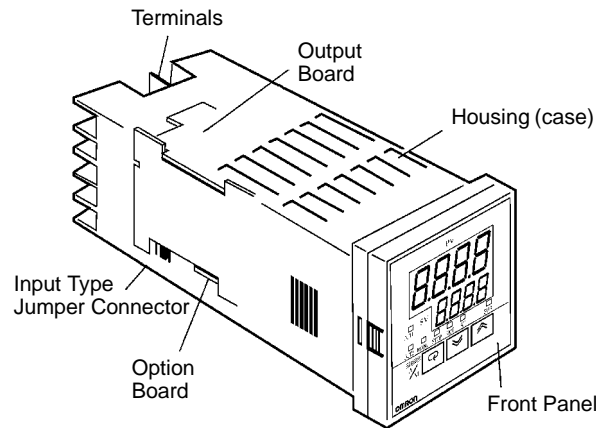

First, while pressing the hooks on the left and right sides of the front panel, pull the internal mechanism from the housing.

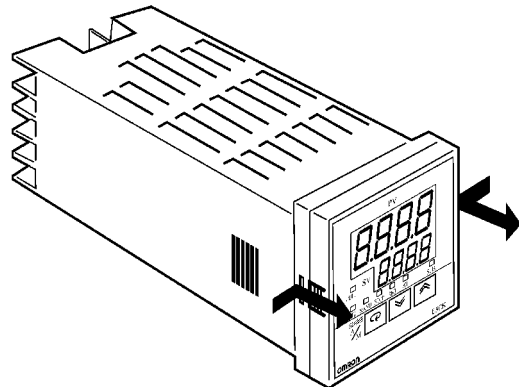

■ SETTINGS

Note: Always turn off the power supply to the Digital Controller before changing any switch settings.

On a standard model, set up the Output Modules for control outputs 1 and 2 before mounting the Controller.

On a position-proportional model, the Relay Output Module is already set. Do not change that set-up parameter. Do not replace with other Output Modules.

Setting Up and Removing the Output Module

Setting Up the Output Module

When setting up the Output Modules, pull out the internal mechanism from the housing and insert the Output Modules into the sockets for control outputs 1 and 2.

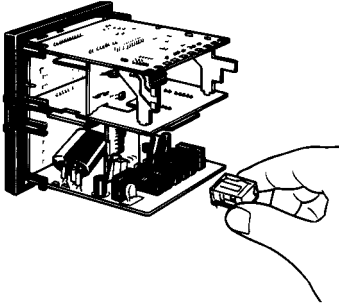

Removing the Output Module

To replace the Output Module, use a flat-blade screwdriver to push up the Output Module.

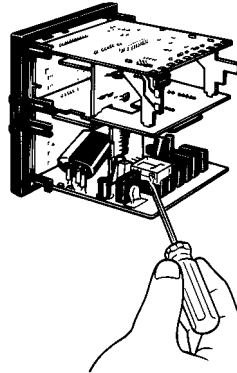

Setting Up the Option/Output Board

E5AK

1. Remove the Power Board and Option Boards in the order shown in the following diagram.
2. Insert the Option Boards into the sockets for options 1 to 3. The following diagram shows the relationship between the Option Boards and mounting positions.

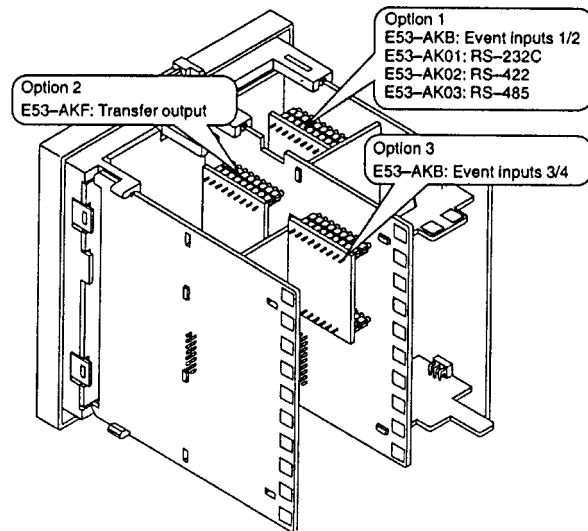
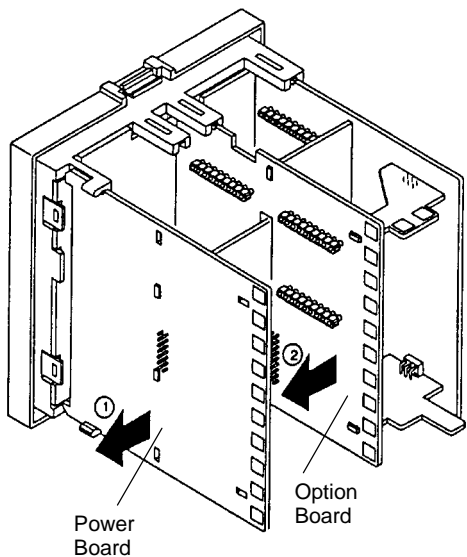

3. Mount the option boards and the power board in the order shown.

E5EK

1. Remove the Power Board in the order shown in the following diagram.

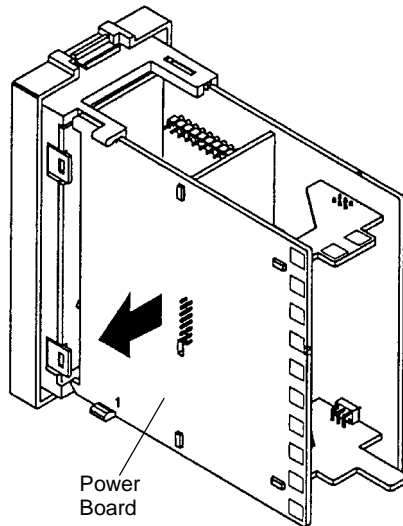

2. Insert the Option Board into the socket for option 1. The following diagram shows the relationship between the Option Board and mounting position.

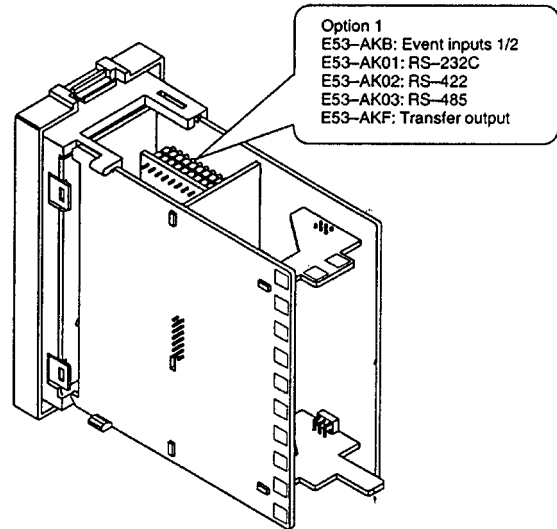

3. Mount the option boards and the power board in the order shown.

E5CK

1. Two rectangular holes are provided on the Power Board (right side of Controller). Fit the two protrusions of the output board into these two holes.
2. With the output board fitted into the Power Board, fit the output board into the connector on the control board (left side of Controller).

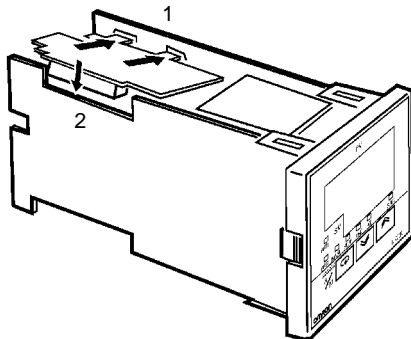
**Set up the Option Board**

1. Place the bottom of the Controller facing up, fit the board horizontally into the connector on the power board (right side of controller).
2. With the Power Board connected, fit the board vertically into the connector on the control board (left side of Controller).

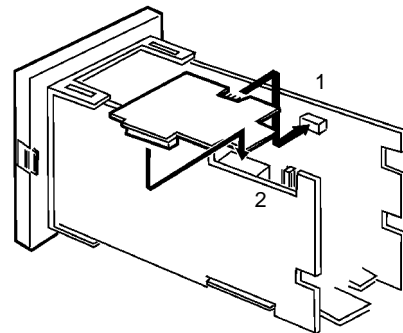

■ MOUNTING CONTROLLER

E5AK and E5EK

1. Insert the controller into the panel's mounting hole at the position shown in the figure below.
2. Fit the mounting bracket (accessory) into the mounting slots on the top and bottom of the rear case.
3. Tighten the mounting bracket screws on the upper and lower parts in small increments alternately and equally until the ratchet start to slide.

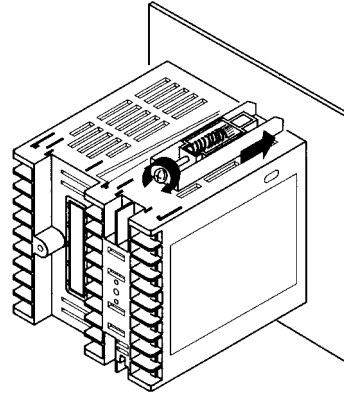
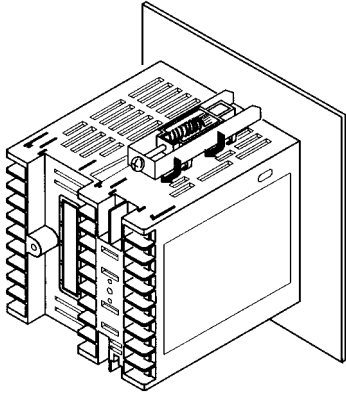

E5CK

1. Insert the E5CK Controller into the cutout on the panel, as shown in the figure here.
2. Push the adapter along the Controller body from the terminals up to the panel, and fasten temporarily.
3. Tighten the two mounting screws on the adapter. When tightening screws, tighten the two screws alternately keeping the torque to approximately 0.29 to 0.39 N • m, or 3 to 4 kgf • cm.

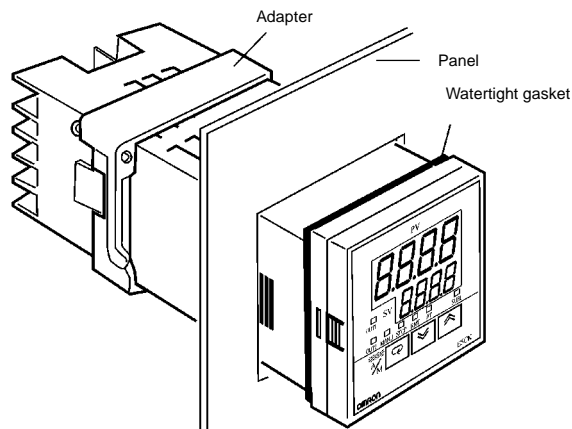

■ MOUNTING TERMINAL COVER

E5AK and E5EK

1. Fasten the terminals covers as follows by using the plastic pins. Plastic pins are provided with the terminal covers.

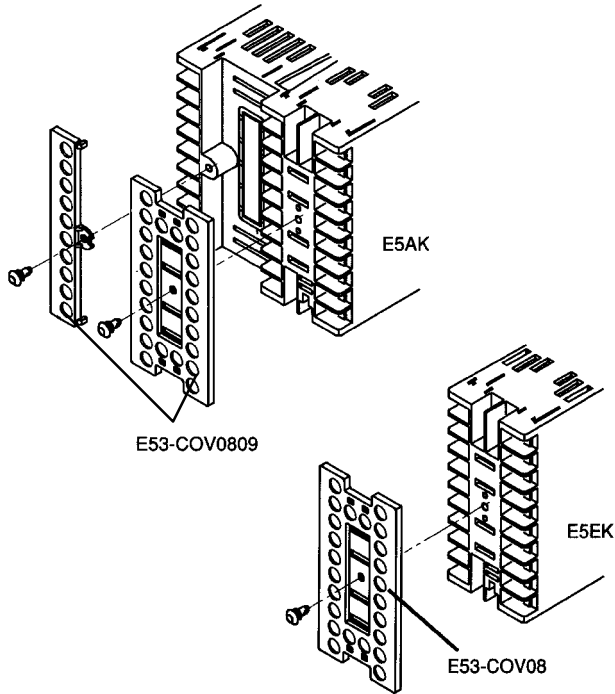

E5CK

1. The E5CK-AA1-500 Controller is provided with a Terminal Cover (E53-COV07). Fasten the Terminal Cover as follows by using the plastic pin.

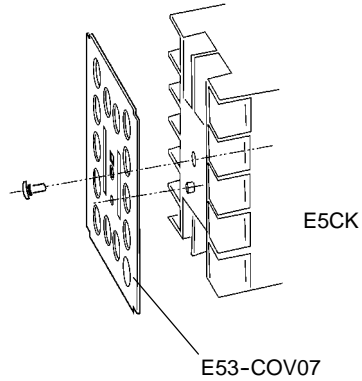

■ WIRING TERMINALS FOR E5AK

E5AK Terminal Arrangement

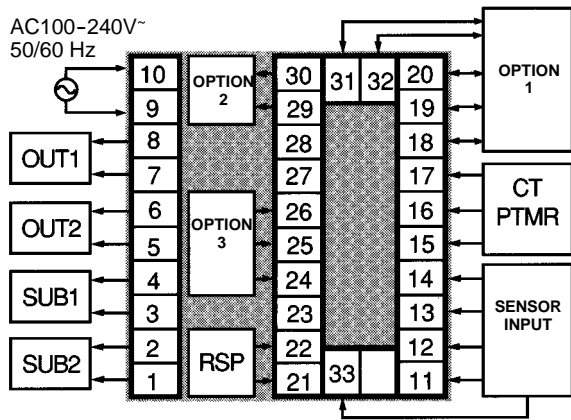

TRSF: Transfer output
 EV1 to 4: Event input
 PTMR: Potentiometer
 RSP: Remote SP input

Wiring

In the following wiring diagrams, the left side of the terminal numbers indicate the inside of the Controller.

Power Supply

Input power to terminal numbers 9 and 10. Power specifications are as follows: 100 to 240 VAC, 50/60 Hz, approx. 16 VA

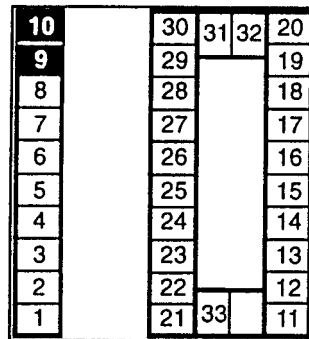

WIRING TERMINALS FOR E5EK

E5EK Terminal Arrangement

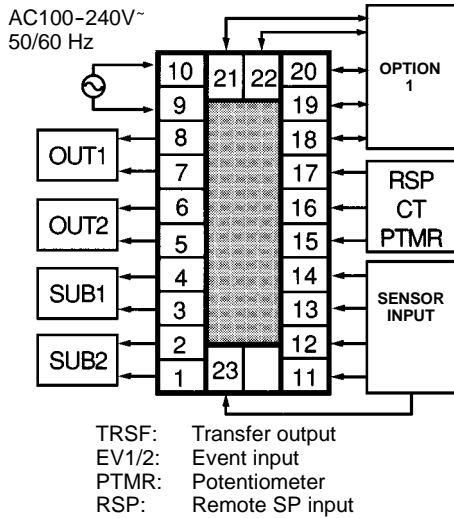

Power supply

Input power to terminal numbers 9 and 10. Power specifications are as follows: 100 to 240 VAC, 50/60 Hz, approx. 15 VA

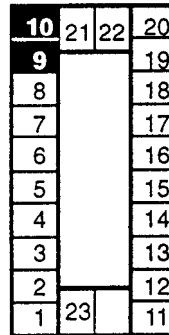

WIRING TERMINALS FOR E5CK

E5CK Terminal Arrangement

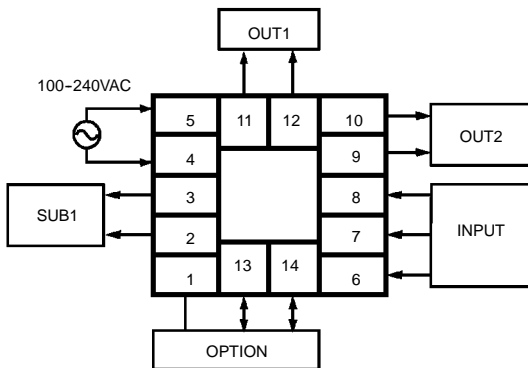

Wiring Precautions

- To protect the Controller and its lines from external noise, use the wire ducts to separate input leads and power lines.
- Use solderless terminals when wiring the Controller.
- Tighten the terminal screws using a torque no greater than 0.78 N • m, or 8 kgf • cm max. DO NOT tighten the terminal screws too tightly.

Power Supply

Input 100 to 240 VAC to terminal numbers 4 and 5.

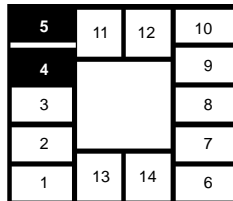

■ SENSOR INPUT WIRING

E5AK

Connect the sensor input to terminal numbers 11 to 14 and 33 as follows according to the input type.

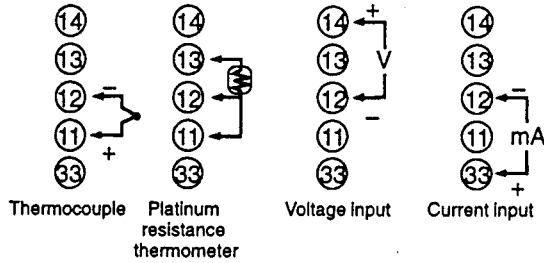
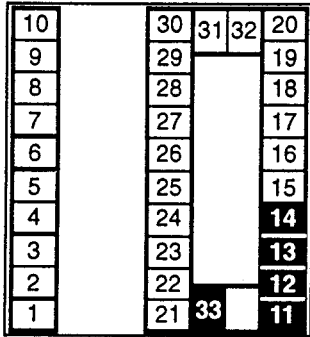

E5EK

Connect the sensor input to terminal numbers 11 to 14 and 23 as follows according to the input type.

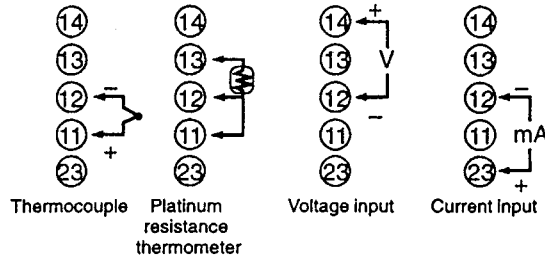
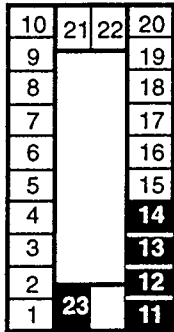

E5CK

Connect the sensor input to terminal numbers 6 to 8 as indicated here, according to the input type.

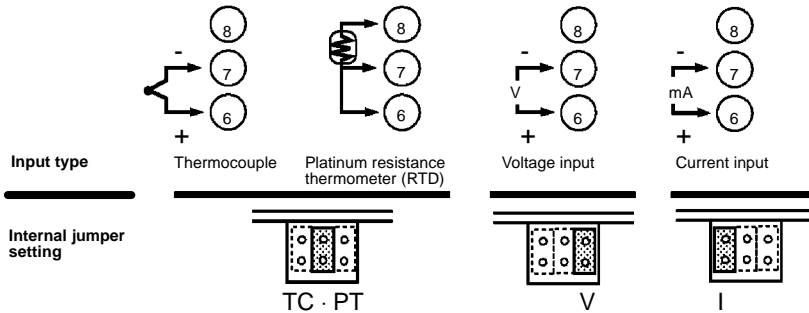
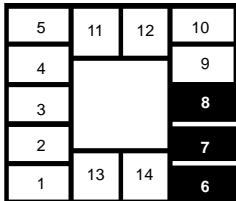

Match the inputs with the internal jumper settings for each input type. For thermocouple or platinum resistance thermometer inputs, set the internal jumper to a common position (TC/PT) as the temperature input.

CONTROL OUTPUT

E5AK Control Output

Terminal numbers 7 and 8 are for control output 1 (OUT1), and terminal numbers 5 and 6 are for control output 2 (OUT2). The following diagrams show the available Output Modules and their internal circuits.

10		30	31	32	20
9		29			19
8		28			18
7		27			17
6		26			16
5		25			15
4		24			14
3		23			13
2		22			12
1		21	33		11

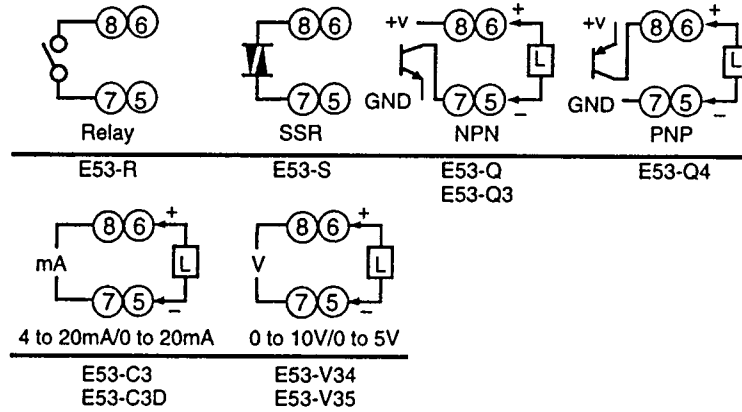

E5EK Control Output

Terminal numbers 7 and 8 are for control output 1 (OUT1), and terminal numbers 5 and 6 are for control output 2 (OUT2). The following diagrams show the available Output Modules and their internal circuits.

10	21	22	20
9			19
8			18
7			17
6			16
5			15
4			14
3			13
2			12
1	23		11

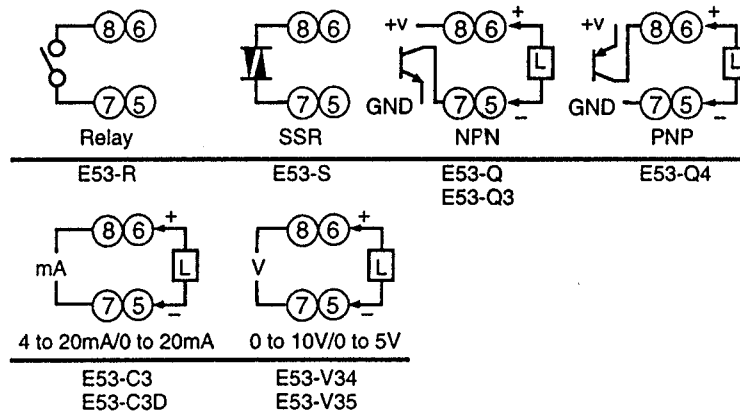

With E53-V□□ Output Modules, approx. 2 V is output for one second after the power is interrupted.

E5AK-PRR2/E5EK-PRR2 Controllers

The E5AK-PRR2 and E5EK-PRR2 Controllers are supplied with relay output. This relay output is not compatible with any other module.

When replacing the Output Module, use the E53-R. The following diagrams show the relationship between terminals and open/close relay settings.

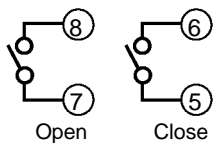

E5CK Control Output

Terminal numbers 11 and 12 are for control output 1 (OUT1). The five output types and internal circuits are available according to the Output Board.

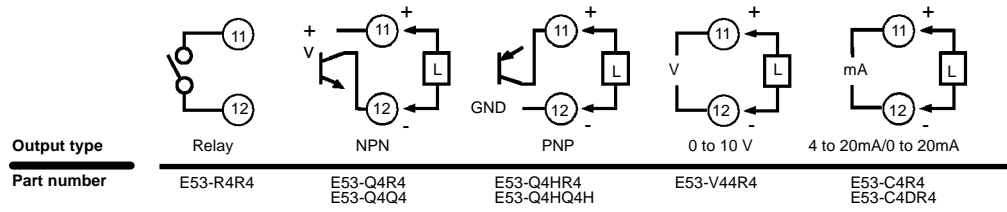
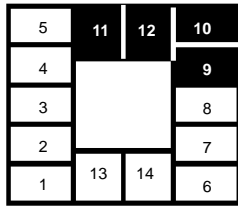

Terminal numbers 9 and 10 are for control output 2 (OUT2). The three output types and internal circuits are available according to the Output Board.

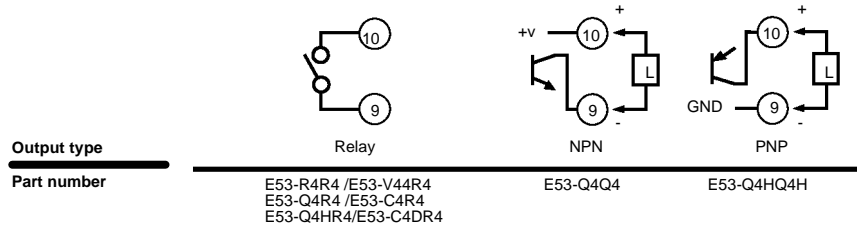

AUXILIARY OUTPUT

E5AK

Terminal numbers 3 and 4 are for auxiliary output 1 (SUB1) and terminal numbers 1 and 2 are for auxiliary output 2 (SUB2). The following diagrams show the internal equalizing circuits for the auxiliary outputs:

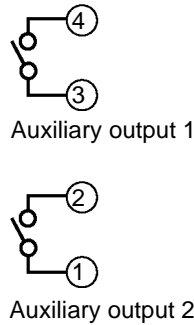
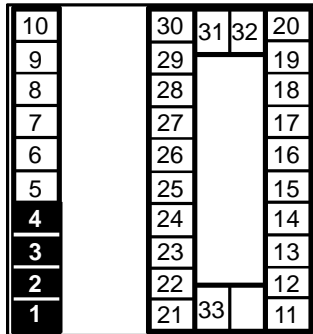

Output specifications are as follows: SPST-NO, 3 A at 250 VAC

E5CK

Terminal numbers 2 and 3 are for auxiliary output 1 (SUB1). The internal equalizing circuit for auxiliary output 1 is as follows:

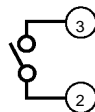
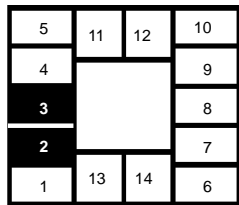

E5EK

Terminal numbers 3 and 4 are for auxiliary output 1 (SUB1) and terminal numbers 1 and 2 are for auxiliary output 2 (SUB2). The following diagrams show the internal equalizing circuits for the auxiliary outputs:

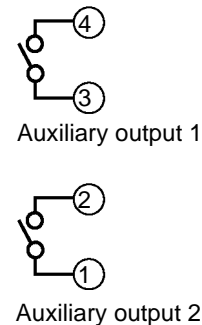
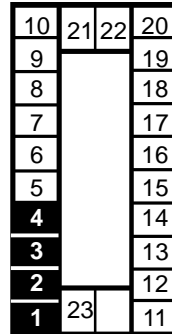

Output specifications are as follows: SPST-NO, 3A at 250 VAC

■ CT INPUT/POTENTIOMETER (FOR E5AK AND E5EK ONLY)

E5AK CT Input/Potentiometer

When using the HBA function on the E5AK-AA2 Controller, connect CT input (CT) to terminal numbers 15 to 17. When monitoring the valve opening on the E5AK-PRR2 Controller, connect the potentiometer (PTMR) to terminal numbers 15 to 17. Connect each of these inputs as follows:

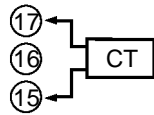
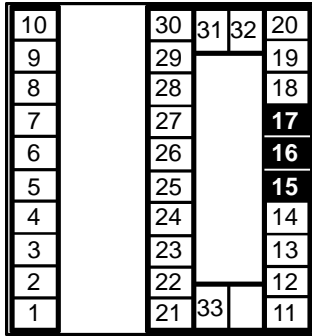

CT input

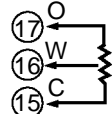

Potentiometer

For details on CT inputs, refer to *Appendix, About Current Transformer* in your *User's Manual*. For details on the potentiometer, refer to the *Instruction Manual* for the valve connected to the Controller. The variable resistance range is 100 Ω to 2.5 k Ω .

E5EK CT Input/Potentiometer

When using the HBA function on the E5EK-AA2 Controller, connect CT input (CT) to terminal numbers 15 to 17. When monitoring the valve opening on the E5EK-PRR2 Controller, connect the potentiometer (PTMR) to terminal numbers 15 to 17. Connect each of these inputs as follows:

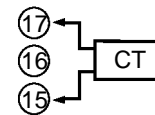
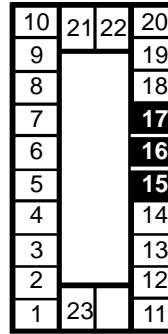

CT input

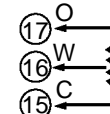

Potentiometer

For details on CT inputs, refer to *Appendix, About Current Transformer* in your *User's Manual*. The potentiometer cannot be used simultaneously with remote SP input. For details on the potentiometer, refer to the *Instruction Manual* for the valve connected to the Controller. The variable resistance range is 100 Ω to 2.5 k Ω .

■ REMOTE SP INPUT (FOR E5AK AND E5EK ONLY)

E5AK Remote SP Input

Connect the input (RSP) to be used as the remote SP to terminal numbers 21 and 22. Only 4 to 20 mA inputs can be connected. Connect the input as follows:

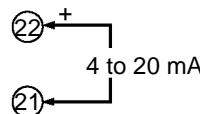
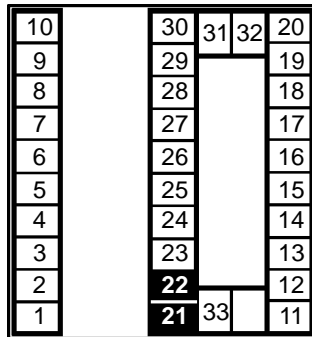

E5EK Remote SP Input

Connect the input (RSP) to be used as the remote SP to terminal numbers 15 and 16. However, note that the potentiometer cannot be used simultaneously with remote SP input. Only 4 to 20 mA inputs can be connected. Connect the input as follows:

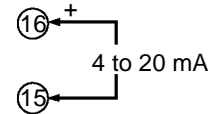
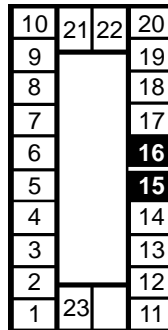

OPTION BOARD WIRING

E5AK

Connect event inputs 1 and 2 (EV1/2) to terminal numbers 18 to 20, and event events 3 and 4 (EV3/4) to terminal numbers 24 to 26. However, note that terminal numbers 18 to 20 cannot be used on Controllers with a communications function. Connect the event inputs as follows:

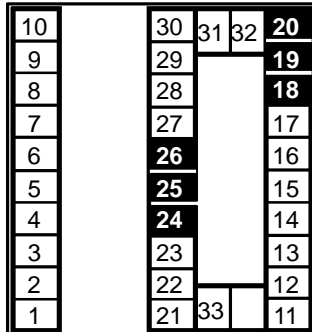

Terminals 18 and 24 (COM) are connected internally.

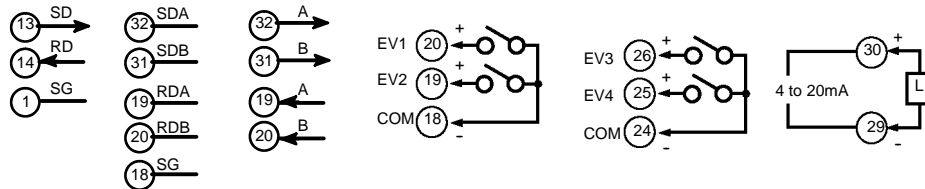

Option type	RS-232C	RS-422	RS-485	Event input 1 and 2 (no contact)	Event input 3 and 4 (no contact)	Transfer output
Part number	E53-AK01	E53-AK02	E53-AK03			

Use event inputs under the following conditions:

Contact input	ON: 1 k Ω max. OFF: 100 k Ω min.
No-contact input	ON: Residual voltage 1.5 V max., OFF: Leakage current 0.1 mA max.

Communications

Terminal numbers 18 to 20, 31 and 32 can be used only on Controllers with Communications Units (E53-AK01/02/03). For details on wiring, refer to *Chapter 6, Using the Communications Function* in your *User's Manual*.

E5EK

Connect event inputs 1 and 2 (EV1/2) to terminal numbers 18 to 20. However, note that terminal numbers 18 to 20 cannot be used on Controllers with a communications function. Connect the event inputs as follows:

10	21	22	20
9			19
8			18
7			17
6			16
5			15
4			14
3			13
2			12
1	23		11

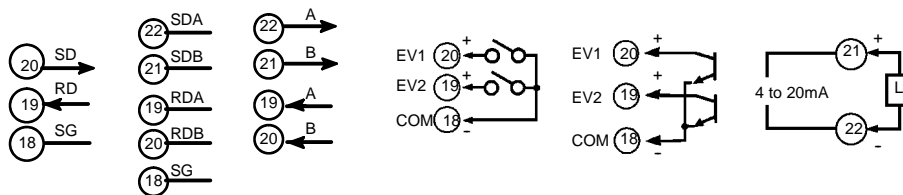

Option type	RS-232C	RS-422	RS-485	Event input 1 and 2	Event input 1 and 2 (no contact)	Transfer output
Part number	E53-AK01	E53-AK02	E53-AK03			

Use event inputs under the following conditions:

Contact input	ON: 1 kΩ max., OFF: 100 kΩ min.
No-contact input	ON: Residual voltage 1.5 V max., OFF: Leakage current 0.1 mA max.

Communications

Terminal numbers 18 to 20, 31 and 32 can be used only on Controllers with Communications Units (E53-AK01/02/03). For details on wiring, refer to *Chapter 6, Using the Communications Function* in your *User's Manual*.

E5CK

Terminal numbers 1, 13, and 14 are valid only when the Option Board is set in the Controller

The following four connections are possible depending on the model of the Option Board.

5	11	12	10
4			9
3			8
2			7
1	13	14	6

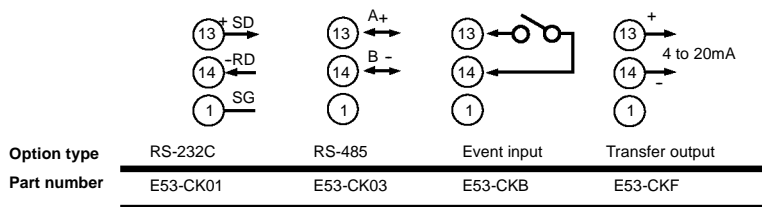

Option type	RS-232C	RS-485	Event input	Transfer output
Part number	E53-CK01	E53-CK03	E53-CKB	E53-CKF

■ CONNECTION EXAMPLE OF DIGITAL CONTROLLER AND SSR

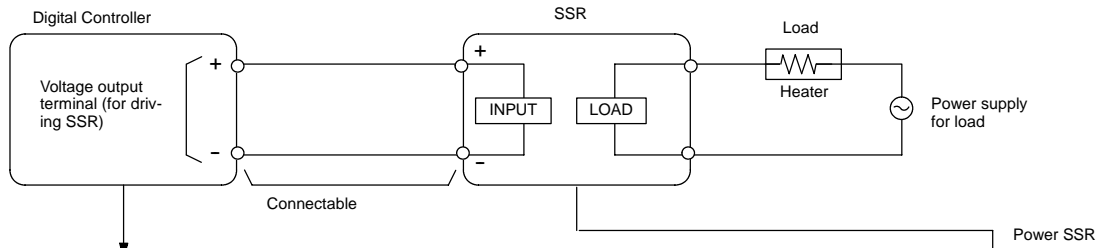

E5AK/E5EK

Digital Controller with Voltage Output (12 VDC, 40 mA max.)

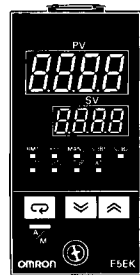

E5CK

Digital Controller with Voltage Output (12 VDC, 20 mA max.)



See the Process and Temperature Controller Catalog GCTC11 for further information on External SSR.

Precautions

■ PRECAUTIONS WHEN WIRING

- Use wire ducts to separate input leads and power lines in order to protect the Controller and its lines from external noise.
- Solderless terminals are recommended when wiring the Controller.
- Tighten the terminal screws using a torque no greater than 0.78 N • m, or 8 kgf • cm max. Take care not to tighten the terminal screws too tightly.

Power Blocks

The E5AK/E5EK has independent power supplies for each of the terminal blocks shown below.

E5AK

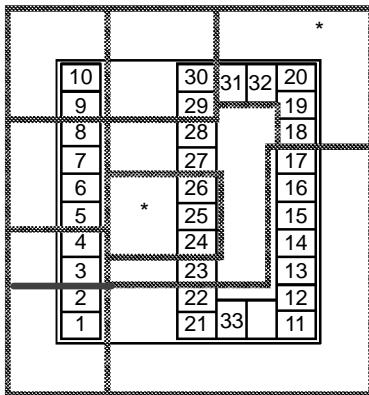

E5EK

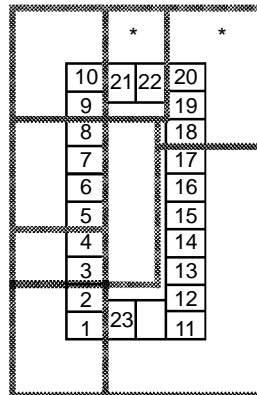

E5CK

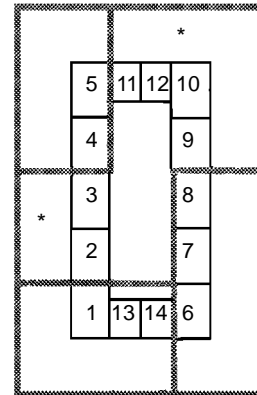

* Uses same internal power supply

Note: Terminals 21 and 22 of the E5EK belong to the B block when a transfer output is set to option 1 and to the C block for other Option Boards.

■ OPERATING ENVIRONMENT

- Keep within the rated ambient operating temperature, ambient operating humidity, and storage temperature ranges.
- Use the Unit according to the vibration resistance, shock resistance, and enclosure ratings.
- Do not use the Unit in places with corrosive gas or excessive dust.
- Do not use the Unit near machines generating high-frequency noise.

■ CORRECT USE

Mounting

- The dimensions of the Digital Controller conform to DIN 43700.
- Recommended panel thickness is 1 to 8 mm.
- Mount the Unit horizontally.

Connection

- To reduce inductive noise influence, the lead wires connecting the input type to the Digital Controller must be separated from the power lines and load lines.
- Use the specified compensating conductors for thermocouples. Use lead wires having a small resistance for platinum resistance thermometers.

Connection Example

- Wire the terminals of the Unit using solderless terminals.
- The tightening torque applied to the terminal screws of the Unit must be approximately 0.78 N • m or 8 kgf • cm.

Use the following type of solderless terminals for M3.5 screws.



■ OPERATION

- For models with alarm functions: The alarm outputs of a model with an alarm function may not turn ON properly when the model malfunctions. The use of alarm equipment with the model is recommended.
- The parameters and internal switch are set before shipping so that the Unit will function normally. Change the settings of the parameters and internal switch according to the application, if necessary.
- Several seconds are required until the relay is turned ON after power has been supplied to the Digital Controller. you must take this time delay into consideration when designing sequenced circuits which incorporate a Digital Controller.
- Do not use excessive force when pulling out the internal mechanism from the housing. Protect the internal connector or electronic parts of the Unit from shock. Protect against static discharge when changing the settings of the internal switch. Changing the settings on a grounded conductive mat is recommended.
- When connecting the Control Output Unit to the Temperature Controller or Digital Controller, make sure that the Control Output Unit is a suitable type. The use of an improper type of Control Output Unit may cause the system to malfunction.
- The heater burnout alarm will not be available if the Linear Output Unit is used.

OMRON®

Omron Europe B.V. EMA-ISD, tel:+31 23 5681390, fax:+31 23 5681397, <http://www.eu.omron.com/ema>