

Replaces Old-fashioned Rotary Cams for Repeat Pattern Control on Conveyors, Wrapping and Food Packaging Machines, etc.

- Choose between 8 or 16 control outputs.
- Store three separate control programs.
- Fine-adjust cycle time without changing the program.
- Wide supply voltage range: 100 to 240 VAC.
- Wide time setting range: 9.99 s to 99.9 hrs.
- Built-in battery protects program memory.
- Quick, accurate response.
- Easy-to-read LED status and setting displays.

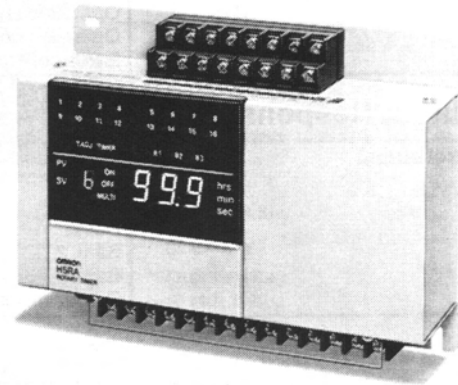

Ordering Information

Operation method	No. of control outputs	Mounting method	Model
Continuous repetition	8	Surface mounting	H5RA-8
	16		H5RA-16

Specifications

■ Time Ranges

Rated time	Setting range	
	Cycle	Output
9.99 s	0.02 to 9.99 s	0.00 to 9.98 s (see note)
99.9 s	0.2 to 99.9 s	0.0 to 99.8 s (see note)
999 s	2 to 999 s	0 to 998 s (see note)
99.9 min	0.2 to 99.9 min	0.0 to 99.8 min (see note)
999 min	2 to 999 min	0 to 998 min (see note)
99.9 hrs	0.2 to 99.9 hrs	0.0 to 99.8 hrs (see note)

Note: Must be within the set cycle.

■ Ratings

Rated supply voltage	100 to 240 VAC (50/60 Hz)
Operating voltage range	90% to 110% of rated supply voltage (90 to 264 VAC, (50/60 Hz))
Power consumption	10 W max.
Control outputs	100 mA at 30 VDC, solid-state (open collector)

■ Input Response Time

Control input	Start 1 Start 2 Gate Reset Bank 2 Bank 3 Output inhibit Operation check 1 Operation check 2 Batch count reset	20 ms + chattering time
---------------	--	-------------------------

■ Output Response Time

Control output	Start 1 Start 2 Gate Reset Bank 2 Bank 3 Output inhibit	20 ms
----------------	---	-------

■ Characteristics

Accuracy of operating time	±0.1%±30 ms (percent of set value)
Influence of voltage	
Influence of temperature	
Cycle time	±0.1%±10 ms (excluding initial cycle)
Reset time	1 s
Memory protection against momentary power failure	10 ms
Memory protection	With built-in battery, 10 years at 25°C
Power-ON time	0.5 s max.
Insulation resistance	100 MΩ min. (at 500 VDC) (between current-carrying and non-current-carrying parts and between power circuit and control circuit)
Dielectric strength	1,500 VAC, 50/60 Hz for 1 min (between current-carrying and non-current-carrying parts and between power circuit and control circuit)
Vibration resistance	Destruction: 10 to 55 Hz with 0.75-mm double amplitude for 2 hrs Malfunction: 10 to 55 Hz with 0.5-mm double amplitude for 10 min
Shock resistance	Destruction: 300 m/s ² (approx. 30G) Malfunction: 100 m/s ² (approx. 10G)
Ambient temperature	Operating: -10°C to 55°C
Ambient humidity	Operating: 35% to 85%
Weight	Approx. 1.3 kg

Nomenclature

Front Panel

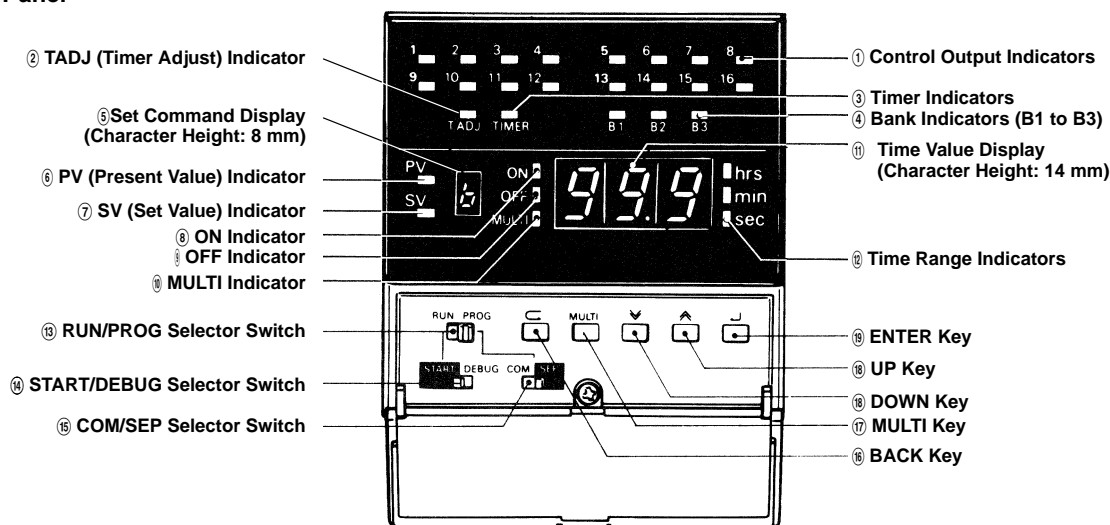

Functional Description

No.	Name	Function
①	Control Output Indicators (1 to 16)	In the PROG mode, these indicators illuminate to indicate that the control outputs of the corresponding control output numbers are being programmed and in the RUN mode, illuminate to indicate that the control outputs of the corresponding output control numbers are being turned ON.
②	TADJ (Timer Adjust)	Illuminates when a value other than % is set in common command parameter "E" in the input display of a timer adjust value.
③	TIMER Indicator	Illuminates while the timer is in operation. (i.e., output monitor during timer operation)
④	Bank Indicators (B1, B2, B3)	One of the B1, B2, and B3 indicators illuminates to indicate that the bank is under execution.
⑤	Set Command Display	Displays a common command parameter (A through E) or the set number of stages (0 through 7) of a separate command parameter.
⑥	PV (Present Value) Indicator	Illuminates while a present time value is being displayed on the time value display.
⑦	SV (Set Value) Indicator	Illuminates while a set time value is being displayed on the time value display.
⑧	ON Indicator	Illuminates to indicate that the ON time is being set.
⑨	OFF Indicator	Illuminates to indicate that the OFF time is being set.
⑩	MULTI Indicator	Illuminates while the multistage setting function is effective.
⑪	Time Value Display	Displays a time value (present value or set value) or an error message.
⑫	Time Range Indicators	One of the "hrs, min, and sec" indicators illuminates to indicate the time unit of the set time range.
⑬	RUN/PROG Selector	A slide switch used to select the RUN switch (Program RUN) or PROG (Programming) mode.
⑭	START/DEBUG Selector	A slide switch used to select the START switch (Execution) or DEBUG (Debugging) mode for the program written with the switches effective only in the RUN mode.
⑮	COM/SEP Selector	A slide switch used to select the COM switch (common command parameter setting) or SEP (separate command parameter setting) mode. This switch is effective only in the PROG mode.
⑯	BACK Key	A key used to verify the contents of the separate or common command parameters programmed for each control output.
⑰	MULTI Key	A key used to operate a control output more than once per cycle.
⑱	UP and DOWN Keys	Keys used to change a time value, control output number, or time range.
⑲	ENTER Key	A key used to enter a value to be set or to advance data while monitoring programmed data.

Operation

Basic Operation

The H5RA is an electronic rotary timer whose control outputs repeatedly turn ON and OFF in a fixed cycle. The H5RA is ideal for controlling machines that repeatedly perform a fixed cycle, replacing old-fashioned electrified cam timers. The operation pattern and cycle time of each output can be easily set or changed by programming, providing flexibility and sophistication. Full details on programming are contained in the H5RA Rotary Timer Operation Manual, available from OMRON.

Timing Chart (Control Output Only)

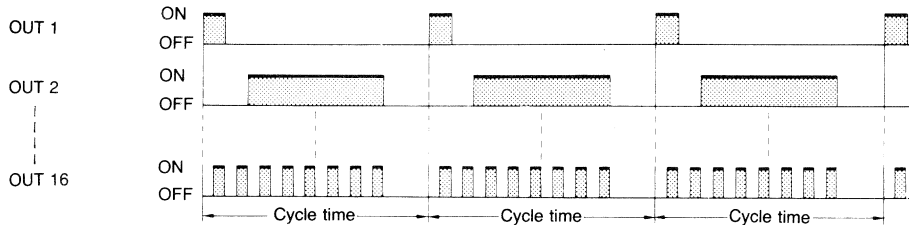

Control Inputs

The control inputs are signals from such things as pushbuttons or external devices which control the operation of the Rotary Timer.

	Name	Function	Description	
Read in at power up	RESET at PW.ON	Specifies the operating mode on power application or recovery.	When this input signal is turned ON, the present time value is reset on power application. When it is OFF, the present time value before power failure is retained.	
	START at PW.ON		When this input signal is turned ON, the timer starts operating on power application. When it is ON, the timer waits until the START 1 or START 2 signal is input.	
	OUTPUT MODE		When this input signal is turned ON, the control outputs remain OFF until either the START signals or the RESET signal is input. When it is OFF, the control output returns to the status before power failure. This input signal has no effect while the START at PW.ON signal is turned ON.	
Normally read in	START 1	Starts the timer.	The timer starts operating at the leading edge of this input signal. It does not detect the trailing edge. Therefore, the timer can be continuously operated by a one-shot input signal. 	
	START 2	Starts and, when one cycle is completed, stops the timer operation.	The timer starts operating at the leading edge of this input signal. After it has detected the trailing edge, the timer stops when the cycle has been completed. 	
	Note: The priorities of the START 1 and 2 signals are the same and thus the timer operates according to the most recent signal. For example, if the timer is started by START 1 and then detects the trailing edge of START 2, it stops at the end of the present cycle.			
	Gate	Pauses the timer operation.	The timer pauses at the leading edge of this input signal. The control output signals retain their present conditions. 	
	RESET	Returns the present time value to 0 and stops the timer operation.	The timer returns its present value to 0 and stops operating at the leading edge of this input signal. 	

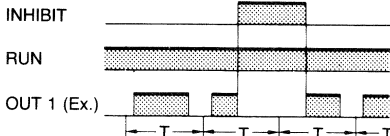
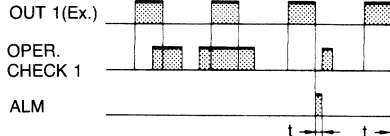
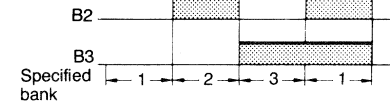
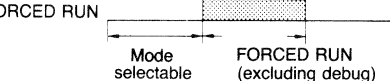
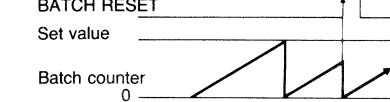
	Name	Function	Description	
Normally read in	INHIBIT	Turns OFF all the control outputs.	The timer turns OFF all the control output signals at the leading edge of this input signal. The output signals remain OFF as long as this signal is ON. The timer can continue the timing even while the outputs are turned OFF. 	
	OPER. CHECK 1	Checks whether the actuator is operating normally.	If this input signal does not turn ON while control output 1 is turned ON, the timer produces an alarm output signal when control output 1 is turned OFF. For one-shot time t, refer to the description of the alarm output. 	
	OPER. CHECK 2		If this input signal does not turn OFF while control output 2 is turned ON, the timer produces an alarm output signal when control output 2 is turned OFF.	
	Note: Both input signals OPER. CHECK 1 and 2 share the same alarm output. Therefore, whether the alarm output has been activated.			
	B2 (Bank 2)	Specifies one of three memory blocks (banks).	A program can be stored in each bank and the program to be executed specified by either or both of these input signals. The program at the specified bank can be changed or executed. Banks 2 and 3 are selected by the corresponding input signal. When the B2 and B3 signals are both OFF or when they are both ON at the same time, bank 1 is selected. Bank selection can be done in the PROG mode or in the RUN mode only when the timer is not timing. 	
B3 (Bank 3)				
FORCED RUN	Forcibly sets the RUN mode to protect the program from damage or loss.	When this input signal is turned ON, the RUN mode is set irrespective of the position of the RUN/PROG selector switch on the front panel. Only when it is turned OFF can the PROG mode and DEBUG mode be specified. 		
BATCH RESET	Resets the present count value of a batch counter.	The batch counter of the specified bank is reset at the leading edge of this input signal. 		

- Note:**
1. These signals are only acknowledged on power application.
 2. In the timing charts in the above tables, T denotes the cycle time.
 3. Of the input signal pulses in the figures in the above tables, the shaded pulses indicate that the input signal is level-sensitive. The pluses not shaded but with up and down arrows indicate that the input signal is edge-sensitive.

Dimensions

Note: All units are in millimeters unless otherwise indicated.

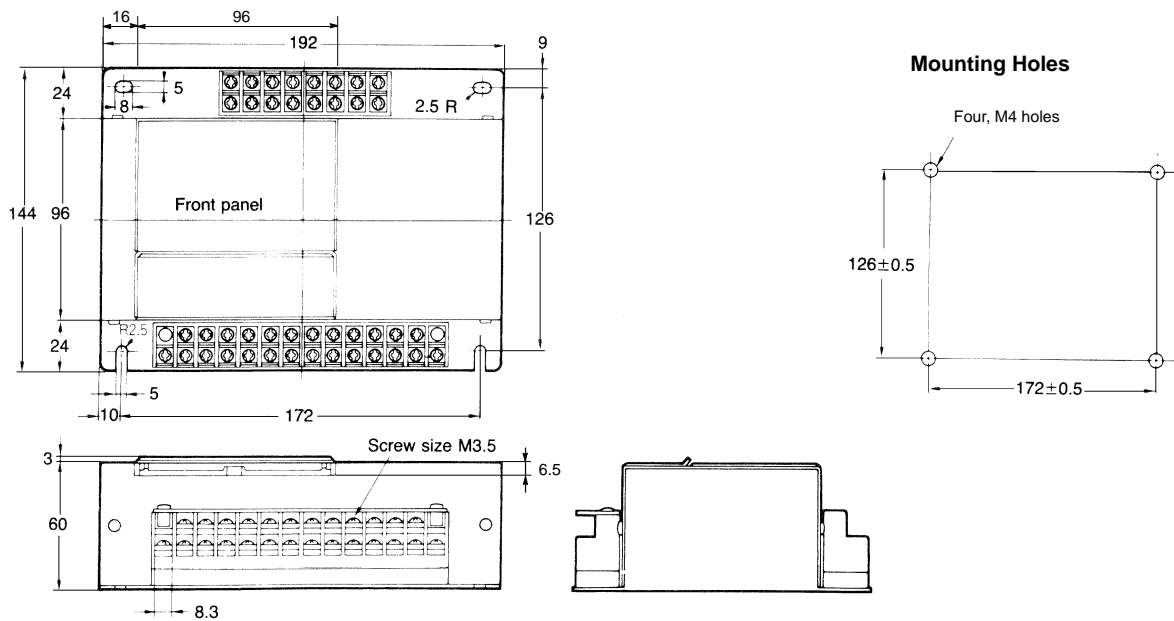

Installation

Input Specifications Circuit Configuration

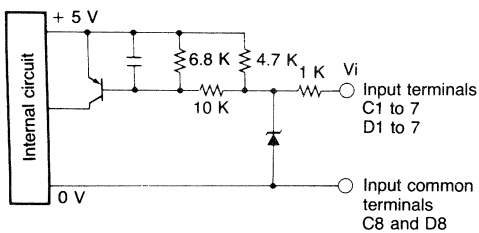

Input current		-2 mA max.
Signal	ON	$V_i = 2\text{ V max.}$
	OFF	$V_i = 4\text{ V min.}$

Terminal Arrangement (Upper Terminals)

Terminal number	D1	D2	D3	D4	D5	D6	D7	D8
Function	OUTPUT MODE	B2	B3	INHIBIT	BATCH RESET	RESET at PW.ON	START at PW.ON	INPUT COM
Terminal number	C1	C2	C3	C4	C5	C6	C7	C8
Function	FORCED RUN	START 1	START 2	GATE	RESET	OPER. CHECK 1	OPER. CHECK 2	INPUT COM

Note: Use the input common terminals even though they are internally connected to the output common terminals.

Connections

Contact Input

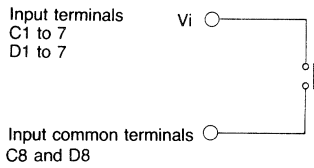

Resistance when contacts are closed: 1 kΩ max.
Resistance when contacts are open: 100 kΩ min.

Solid-state, No-voltage Input

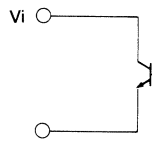

Residual voltage V_i between input terminals when transistor is ON: 2 V max.
Impedance when transistor is OFF: 100 kΩ min.

Solid-state, Voltage Input

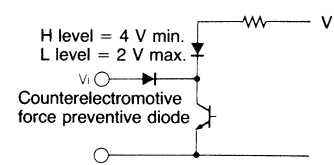

Residual voltage V_i between input terminals when transistor is ON: 2 V max.
Impedance when transistor is OFF: 100 kΩ min.

Note: Be sure to connect a diode to protect the output transistor from counterelectromotive force.

Output Specifications
Circuit Configuration

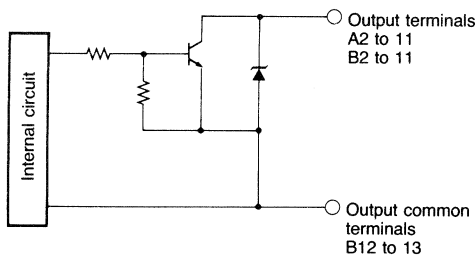

Output type	Solid-state open collector
Dielectric strength	30 V
Permissible current	100 mA
Residual voltage	1.0 V max.
Leakage current	0.1 mA max.

Terminal Arrangement (Bottom Terminals)

Terminal number	A1	A2	A3	A4	A5	A6	A7	A8	A9	A10	A11	A12	A13	A14
Function	---	ALM	RUN	OUT 1	OUT 2	OUT 3	OUT 4	OUT 5	OUT 6	OUT 7	OUT 8	S1 (power)	S2 (power)	---
Terminal number	B1	B2	B3	B4	B5	B6	B7	B8	B9	B10	B11	B12	B13	B14
Function	---	BATCH	READY	OUT 9	OUT 10	OUT 11	OUT 12	OUT 13	OUT 14	OUT 15	OUT 16	OUTPUT COM	OUTPUT COM	FG

- Note:**
1. Terminals B4 through B11 of H5RA-8 are not to be used.
 2. Use the input common terminals even though they are internally connected to the output common terminals.

Connections

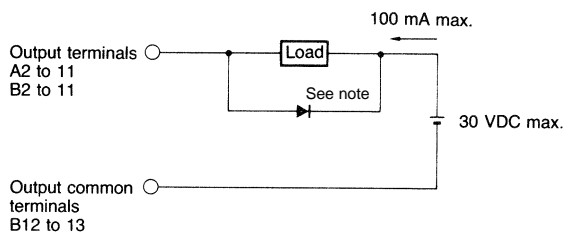

Note: When using an inductive load, be sure to connect a diode to protect the output transistor from counterelectromotive force.

ALL DIMENSIONS SHOWN ARE IN MILLIMETERS.

To convert millimeters into inches, multiply by 0.03937. To convert grams into ounces, multiply by 0.03527.

Cat. No. L80-E1-3 **In the interest of product improvement, specifications are subject to change without notice.**

OMRON Corporation

Systems Components Division
28th Fl., Crystal Tower Bldg.
1-2-27, Shiromi, Chuo-ku,
Osaka 540 Japan
Phone: 06-949-6012 Fax: 06-949-6021

Printed in Japan
0697-0.5C (0696)