

OMRON

Model **F39—MC11**

Setting Console

<h1>INSTRUCTION MANUAL</h1>

Thank you for selecting OMRON product. This manual primarily describes precautions required in installing and operating the product.

Before operating the product, read this manual thoroughly to acquire sufficient knowledge of the product. For your convenience, always keep this manual at hand.

PRECAUTIONS IN USING THE PRODUCT

When the product is used under the circumstances or environment stated below, ensure adherence to limitations of the ratings and functions.

Also, take countermeasures for safety precautions as a system.

1. Use under the circumstances or environment which are not described in this instruction sheet.
2. Use for the equipment which requires higher level of safety, such as nuclear devices, railroad, aircrafts, vehicles, combustion devices, medical equipment, space development technology devices and amusement machinery.

Precaution on Safety

● Indications and their meanings for safe use

In order to use the product safely, adhere to the following precautions. The items indicated here are very important to your safety, be sure to observe them at all times.

Indications and their meanings are as follows.



WARNING

Indicates a potentially hazardous situation which, if not avoided, could result in death or serious injury.



Indicates prohibited actions.



WARNING

F39-MC must be managed and used only by qualified persons. Operation by un-qualified persons could create a hazardous condition which may lead to a loss of safety function.

After the changing the setting of the sensor, a start-up check must be conducted. Normal operation can only be allowed after safety is confirmed.

In order prevent access to a dangerous area, a fixed barrier guard must be placed in fixed blanked areas.

Failure to do so may result in serious injury.

Use of floating blanking function involves a change of the safety distance. Always recalculate and re-measure the safety distance to confirm that it meets the applicable standards, after the change. Failure to do so may cause the machine to fail to stop before an operator reaches a dangerous area, and may result in serious injury.

A change of the setting can only be done under observance of laws/standards which are related to safe operation of the product.



CAUTION

Do not connect the F39-MC to any equipment other than for what it intended to be used with.

Notice

Do not connect to voltage exceeding the stated values.

Doing so may cause damage to the product.

Do not expose the F39-MC to water on the product.

Doing so may cause damage to the product.

Correct Usage

Always power OFF the sensor when connecting or disconnecting the F39-MC.

When F39-MC is not in use, disconnect it from the sensor.

Table of Contents

1	DESCRIPTION	1
2	RATING	3
3	NOMENCLATURE	4
4	WIRING/CONNECTION	6
4.1	Mounting branching connector	6
4.2	Diagram for Wiring of Branching Connector	7
4.3	Connecting F39-MC	8
5	POWER ON	9
6	FUNCTION SELECTION	10
7	CHANNEL SELECTION	11
8	MONITOR/SET	13
8.1	Fixed blanking	15
8.2	Floating blanking	18
8.3	Auxiliary output	20
8.4	Output2	20
8.5	External indicator output	23
8.6	External device monitoring	24
8.7	Start interlock	25
8.8	Restart interlock	26
8.9	Threshold adjustment	27
8.10	Setting initialization	28
8.11	ID setting	29
9	COPY	30
9.1	Upload (Copy Sensor data to F39-MC)	31
9.2	Download (Copy F39-MC data to Sensor)	32
9.3	Bank Lock (Prohibit overwriting to bank data)	33
10	PROTECT	34
10.1	Setting lock	35
10.2	Change password	36
10.3	Setting limitation	37
11	DISCONNECT F39-MC	39
12	ERROR CODES	40
13	TROUBLESHOOTING	41
ANNEX1	INDEX	42
ANNEX2	FUNCTION LIST (according to sensor type)	44
ANNEX3	FUNCTION SETTING CARD	47

1 DESCRIPTION

The Setting consol Model F39-MC11 (hereafter referred to as F39-MC) can be connected to Safety Light Curtain Series—Model F3SN, Multi-beam Safety Sensor series—Model F3SH, and Area Scanner series—Model F3ZN. The F39-MC allows you to change or monitor the setting of these sensors.

Available setting functions are as follows;

Function	Setting	F3SN	F3SH	F3ZN
Monitor/ Set	•Fixed blanking	○	×	○
	•Floating blanking	○	×	○
	•Auxiliary output	○	○	×
	•Output2	×	×	○
	•External indicator output	○	○	○
	•External device monitoring	○	○	×
	•Start interlock	○	○	×
	•Restart interlock	○	○	×
	•Threshold adjustment	×	×	○
	•Setting initialization	○	○	○
	•ID setting	○	○	○
Copy	•Upload	○	○	○
	•Download			
	•Bank lock			
Protect	•Setting lock	○	○	○
	•Change password			
	•Setting limitation			

○ – accessible, × – not accessible

Outline of operation procedure is as shown in the following flow chart.

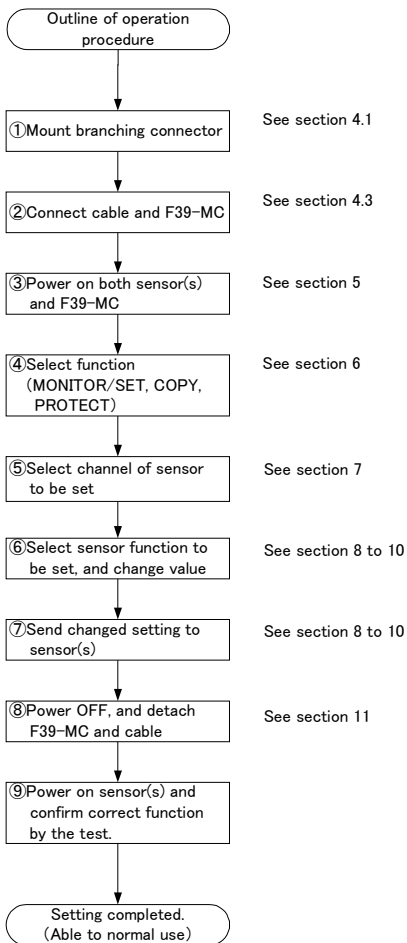

2 RATING

Models		F39-MC11
Items		
Applicable sensor		F3SN, F3SH, F3ZN Series
Communication method		Specified method
Communication connecting method		RS-485
Power supply		24VDC \pm 10% (share sensor's power supply)
Current consumption		55mA maximum
Ambient temperature (during operation)		-10°C to 55°C (with no freezing)
Ambient temperature (during storage)		-25°C to 65°C
Ambient humidity		25 to 85%RH (with no condensation)
Insulation resistance		20M Ω min. (at 500VDC)
Dielectric strength voltage		1,000VAC at 50/60Hz for 1min.
Material	Case	ABS
	Window	Polycarbonate
Weight		Approx. 87g (without accessories) Approx. 360g (when packed)
Accessories		Branching connector, Cable(2m), Connector cap, Instruction manual

3 NOMENCLATURE

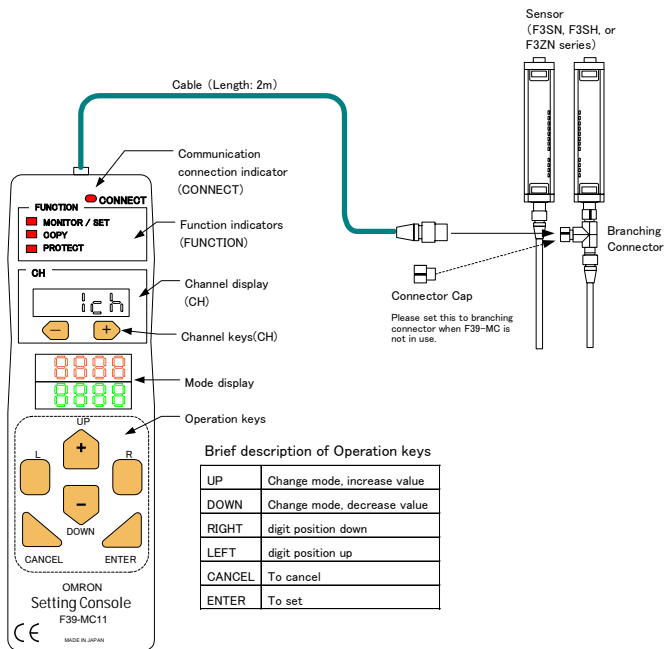

3.1 Communication connection indicator (CONNECT)

This indicator will light up when F39-MC is connected to the sensor.

F39-MC cannot be used when this indicator is not lit.



3.2 Function indicators (FUNCTION)

The indicator of the function being set is lit.

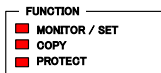

3.3 Channel display(CH) and channel keys

Using +/- keys, select sensor to be set by F39-MC.

Number of selected channel appears on display.

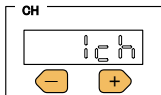

3.4 Mode display

Displays function and value when making a setting.

Basically the top row indicates Setting function and the bottom row Setting value.

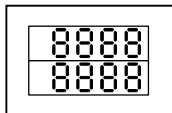

3.5 Operation keys

Used for mode change, setting and canceling.

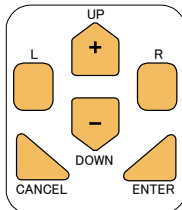

4 WIRING/CONNECTION

4.1 Mounting branching connector

Mount a branching connector to sensor. The connector can be mounted either on emitter or receiver.

When mounted on receiver

When mounted on emitter

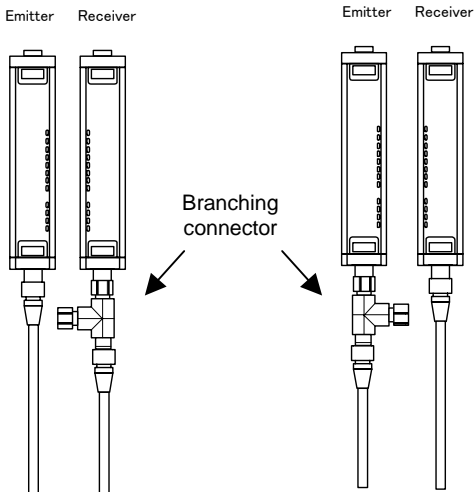

4.2 Diagram for Wiring of Branching Connector

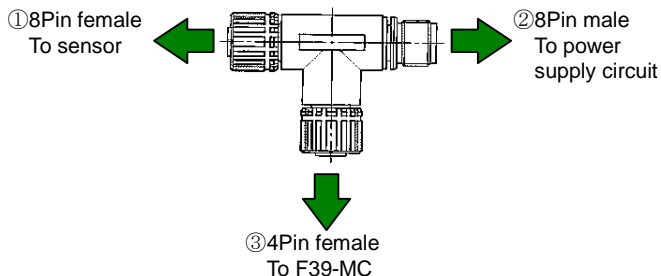

Front View	Pin No.	Signal
	1	+24 V (24VDC)
	2	RS-485(A)
	3	0V
	4	RS-485(B)

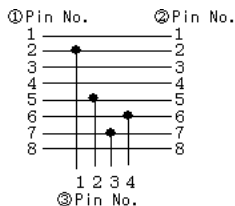

<Note>

The F39-MC receives its power from the sensor. Select a power supply with sufficient current to allow for the additional consumption of the F39-MC (55mA maximum).

4.3 Connecting F39-MC

Insert M12 connector of the cable into Branching connector and the other end into the F39-MC.

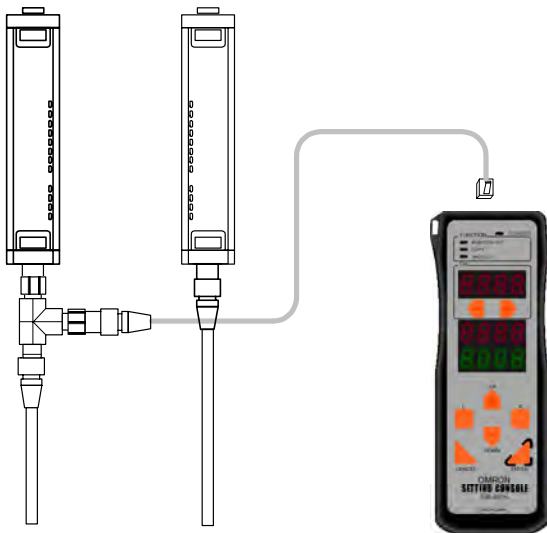

<Note>

1. Do not connect 2 or more F39-MC to one pair of sensor. Normal operation cannot be achieved. Also, combined use of F39-MC and F3ZP, area scanner controller, is not allowed.
2. When F39-MC is not in use, the cable and F39-MC must be removed and Branching connector must be covered with connector cap (Model XS2Z-12).
Without the connector cap, water resistance cannot be maintained.
3. When connecting or disconnecting the F39-MC, be sure that the power is OFF.

5 POWER ON

Power supply of F39-MC is shared with that of the sensor.
The F39-MC turns ON with the power supply of the sensor.



When the F39-MC power is ON, it confirms its connection to sensor. When connection is succeeded, it displays as follows;

- Communication connecting indicator is lit.
- Displays F39-MC's model and version in mode display (for 1 second)
- Displays connected sensor model in mode display, (for 1 second)

(Figure shown left represents when connected to Model F3SN-A.)

<Note>

1. When F39-MC power is ON, the state of sensor becomes as follows.
 - The safety output of F3SN and F3SH is OFF. Also, indicators located at bottom (see fig. on right) are flashing.
 - The output of F3ZN is OFF only during sending data to F3ZN. During non-access time, normal operation can be conducted except that the response time increases by 1ms.
2. Do not disconnect the F39-MC during power ON-state. Malfunction may result.

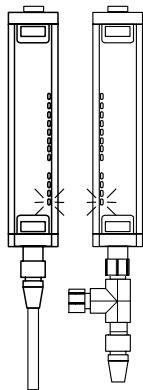

6 FUNCTION SELECTION

1. Using [UP][DOWN] keys, select the function. Display of selected function flashes.
2. Function selecting method is shown below.

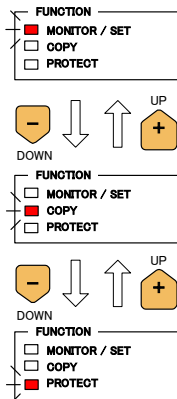

3. By pressing [ENTER] when the selected function is displayed, editing of selected function becomes possible. The indicator of the function selected will light.
4. For editing method of each function, please refer to the item of respective function.
 - Monitor/Set Section8 (page13)
 - Copy Section9 (page30)
 - Protect Section10 (page34)

7 CHANNEL SELECTION

When changing the setting of the sensor with the F39-MC, select the channel in order to determine which sensor is to be set.

Selecting channel (CH) method is as follows;

When series connected, the closest sensor to the extension cable becomes 1CH and the second closest becomes 2CH.

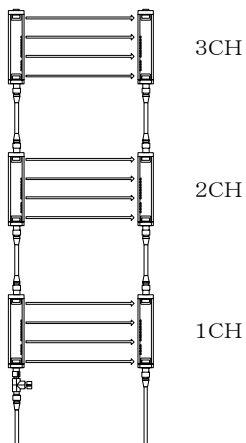

Channel Numbers in Series Connection

Changing selected channel
when connected to three sensors

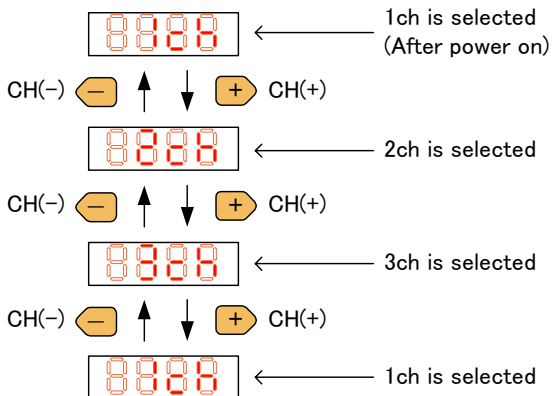

The indicator will be displayed as illustrated below, depending on which function is to be set. This indicates that a setting item is to be proceeded to all the sensors.



<Note>

If the channel is changed while making a setting, content of the setting will be cancelled.

**WARNING**



After the changing the setting of the sensor, a start-up check must be conducted. Normal operation can only be allowed after safety is confirmed.

A change of the setting can only be done under observance of laws/standards which are related to safe operation of the product.

This function enables the monitoring of current set values and functions of the sensor. When a set value is changed, content of the change is reflected on sensor. The value which is indicated first in each category is the current set value.

The method of change into each mode is as illustrated below.

By pressing [ENTER] key when the selected function is displayed, editing of selected function becomes possible.

 Blinking  [UP][DOWN]Key

(i)F3SN

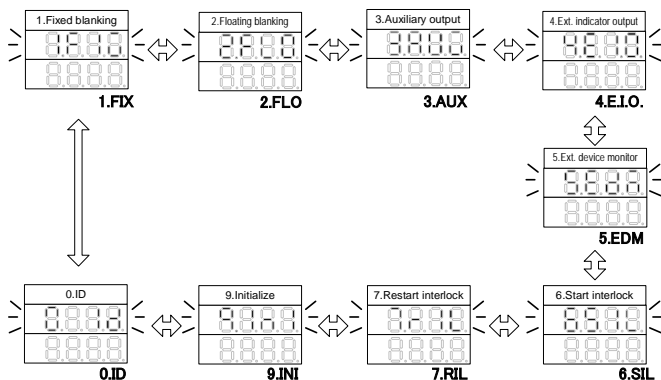

(ii)F3SH

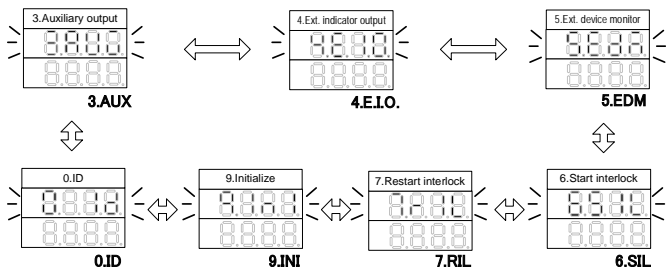

(iii)F3ZN

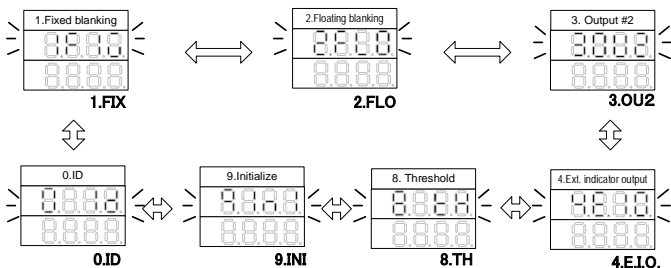

<Common Note for MONITOR/SET function>

1. Edited value will not become active if NOT “SEND” to sensor, nor “Function Valid (1.Fun-on)” is not selected.
2. “Loc” may display if “Setting lock” or “Setting limitation” has been set. See clause 10.1 and 10.3.

8.1 Fixed blanking

<F3SN, F3ZN>



WARNING

In order prevent access to a dangerous area, a fixed barrier guard must be placed in fixed blanked areas.
Failure to do so may result in serious injury.

Fixed blanking function partly voids detection zone of sensor. Entrance of object into invalid detection zone does not change output status.

There are two ways to choose which zone is to be blanked.

1. Teaching :Block beams which are to be selected. Error will be displayed if there are no blocked beams.
2. Manual :Select beam number first, and then choose blanked/not blanked for each selected beam. Beams are numbered as below figure.

<Note>

In case a blanked beam becomes clear, F3SN will automatically invalids fixed blanking function, i.e. no blanked beam will exists.

Reset of power makes previous fixed blanking setting active.

Be sure to use every blanked beam blocked.

The above function is only implemented on F3SN, where safety is necessary. For F3ZN, fixed blanking function continues even if blanked beam becomes clear.

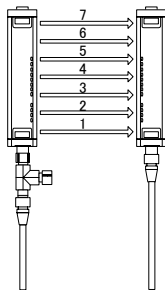

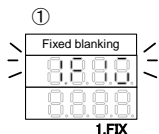

Blinking

→ [Enter] Key

→ [Cancel] Key

↔ [Up][Down] Key

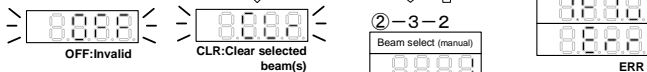
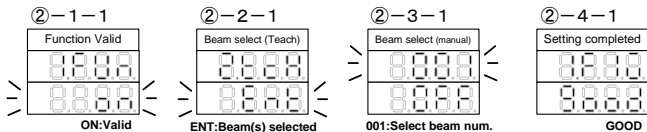
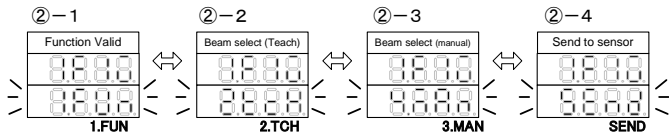

Go to ①
after 1 sec.

Go to ②-2



OR

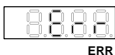

When "taught", blocked beams are selected.

Note: When "Enter" key pressed with no blocked beams, "Err" is displayed.

Go to ②-3
after 1 sec

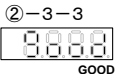
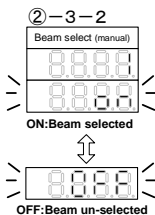

OR



Go to ②-4
after 1 sec

Example of how to set fixed blanking.

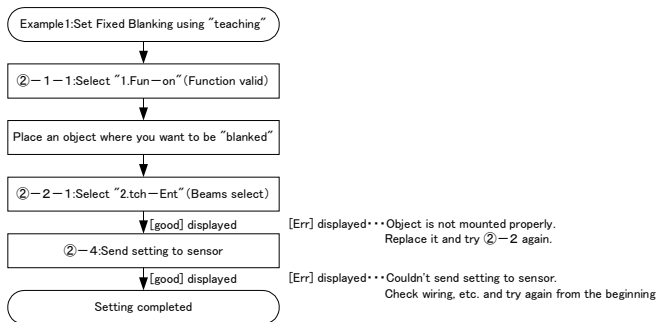

ONE POINT:

After setting has completed, you can confirm the blanked beam numbers by using ②-3: Manual Beam select menu.

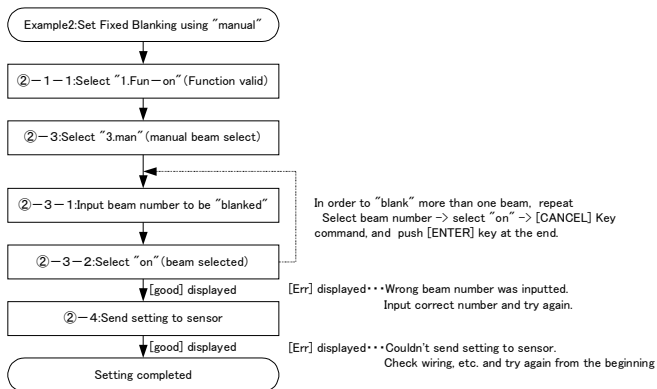

8.2 Floating blanking

<F3SN, F3ZN>



WARNING

Use of floating blanking function involves a change of the safety distance. Always recalculate and re-measure the safety distance to confirm that it meets the applicable standards, after the change. Failure to do so may cause the machine to fail to stop before an operator reaches a dangerous area, and may result in serious injury.

Floating blanking function allows the output to remain ON when beams of the sensor are interrupted anywhere in the field. In contrast with fixed blanking function, which invalids fixed detection area, floating blanking function ignores object smaller than specified radius.

Floating can be set for 1 to 3 floating beams.

(When 1 floating beam is set, sensor will turn OFF when 2 or more beams are blocked).

<IMPORTANT>

The resolution of F3SN will change by floating blanking function (see chart below). Always re-calculate safety distance after any changes in floating blanking function.

The below chart also showing undetectable object diameter, but this value may increase according to sensor alignment condition.

Floating beam Beam gap(mm)	Resolution (mm)				Undetectable dia. (mm)		
	0	1	2	3	1	2	3
9	14	23	32	41	4	13	22
15	25	40	55	70	5	20	35
30	40	70	100	130	20	50	80
60	70	130	190	250	50	110	170

The following modes can be set in floating blanking function;

1 Sequential beam mode

- ON: Output becomes OFF when consecutive blocked beams exceeds floating beams. Output will not becomes OFF when

plural objects smaller than undetectable diameter exist.

- OFF: Output becomes OFF when sum of blocked beams exceeds floating beams. Output may become OFF when plural objects smaller than undetectable diameter exist.

2 Outermost beam invalid mode

Outermost beam invalid mode excludes outermost beams from floating blanking.

When this mode is valid, the output will turn OFF if one of the outermost beams is blocked, even if floating blanking is active.

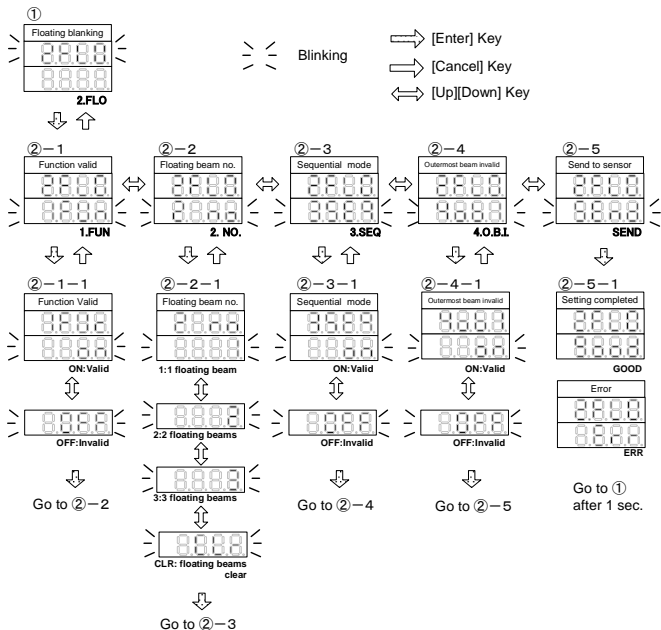

8.3 Auxiliary output

<F3SN, F3SH>

This is a non-safety related output used to display a status.
This output cannot be used for the purpose of safety.

This can be selected to the following output;

1. Dark ON
2. Light ON
3. Light diagnosis
4. Lockout
5. Outermost beam monitoring
6. Blanking monitoring
7. Specified beam

For detail of each output, please refer to ANNEX1 INDEX.

<Note>

Because F3SH does not have fixed blanking function, 6. Blanking monitoring is not selectable.

8.4 Output2

<F3ZN>

This is a output of F3ZN used to display a status.
Available signals are the same as 8.3 Auxiliary output.

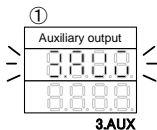

Blinking

→ [Enter] Key

→ [Cancel] Key

↔ [Up][Down] Key

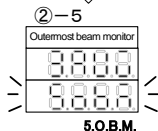
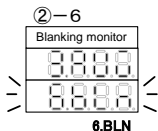
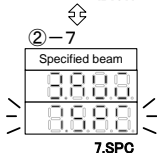
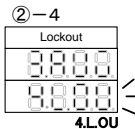
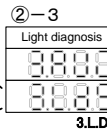
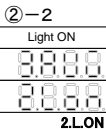
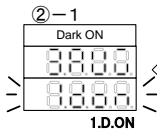

(Only when ②-7 is selected, go to ③-1)

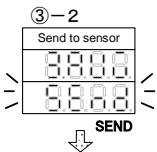

Go to ① after 1 sec.

③-1 (from ②-7)

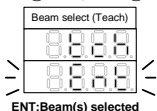

When "taught", blocked beams are selected.

Note: When "Enter" key pressed with no blocked beams, "Err" is displayed.



Go to ③-2 after 1 sec.

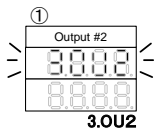

⏏ Blinking

➡ [Enter] Key

➡ [Cancel] Key

↔ [Up][Down] Key

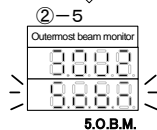
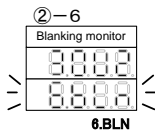
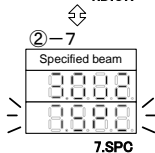
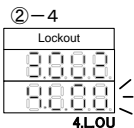
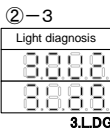
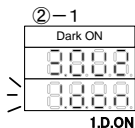

(Only when ②-7 is selected, go to ③-1)

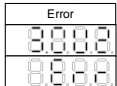
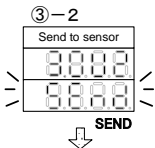

Go to ① after 1 sec.

③-1 (from ②-7)

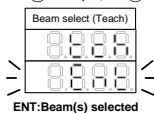

When "teached", blocked beams are selected.

Note: When "Enter" key pressed with no blocked beams, "Err" is displayed.



GOOD
OR



Go to ③-2 after 1 sec.

8.5 External indicator output

<F3SN, F3SH, F3ZN>

This is a non-safety related output which can be connected to an optional indicator, such as F39-A01P□-□.

Applicable only to the models which can be connected in series.

This can be selected to the following output;

1. Dark ON
2. Light ON
3. Light diagnosis
4. Lockout

For detail of each output, please refer to ANNEX1 INDEX.

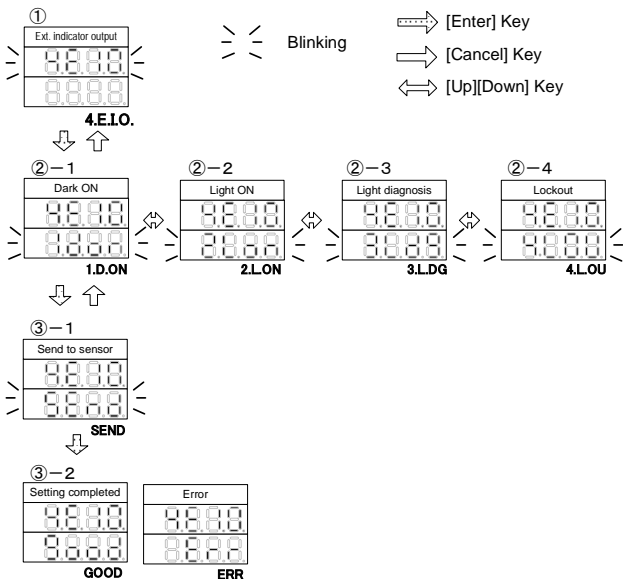

Go to ①
after 1 sec.

8.6 External device monitoring

<F3SN, F3SH>

This function can detect malfunction of external device which controls hazardous area of machine. (e.g. contact welding)

The determination time can be set in respect to the response time of relay being used.

The setting time must be between 100ms to 600ms and can be set in 5ms increments.

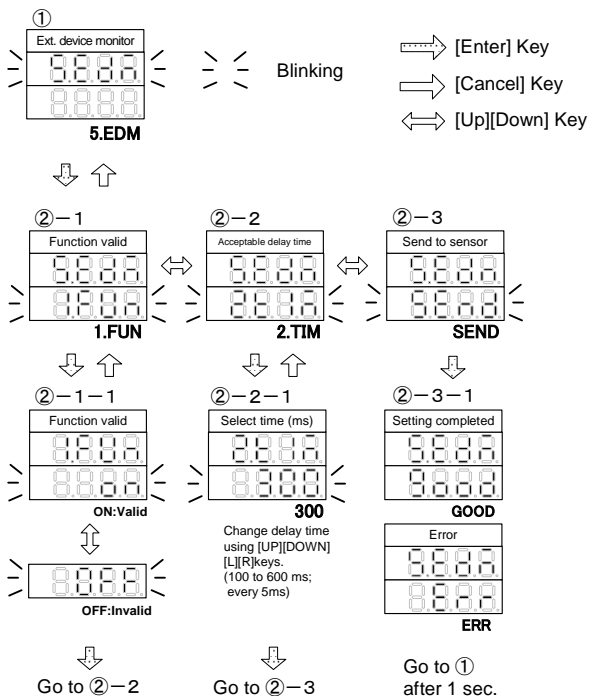

8.7 Start interlock

<F3SN, F3SH>

When this function is ON, the outputs remain in the OFF-state (i.e. interlock state) after power ON. Interlock state can be released by a manual reset when there are no obstructions in the detection zone.

<Note>

This function is valid only when using manual reset mode. When in auto reset mode, the start interlock function is automatically disabled.

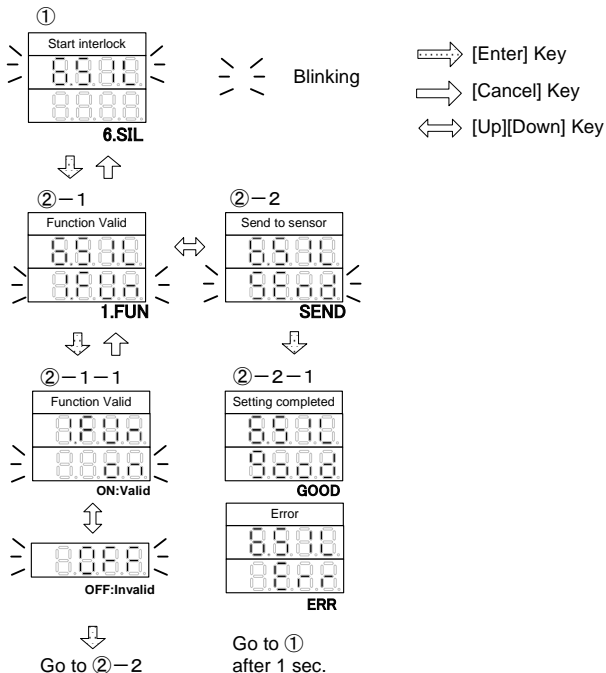

8.8 Restart interlock

<F3SN, F3SH>

When this function is ON, the outputs remain in their OFF-state (i.e. interlock state) when sensor is interrupted. Interlock state can be released by a manual reset when there are no obstructions in the detection zone.

<Note>

This function is valid only when using manual reset mode. When in auto reset mode, the start interlock function is automatically disabled.

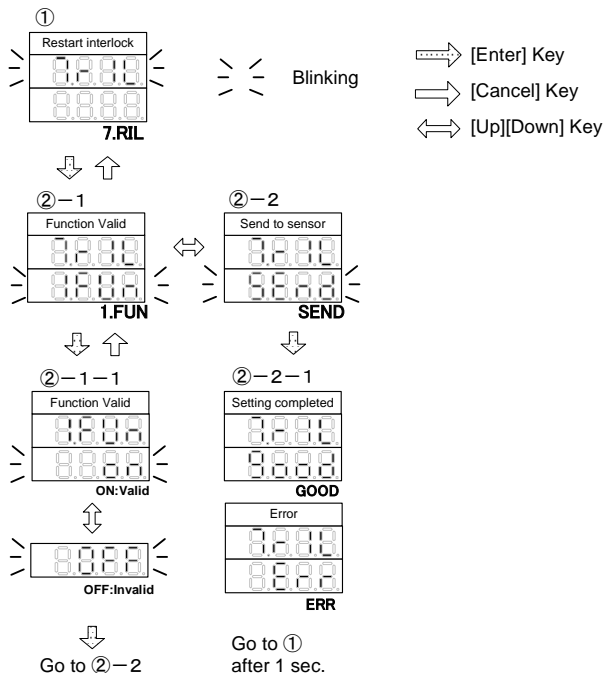

8.9 Threshold adjustment

<F3ZN>

This function enables to adjust threshold value of F3ZN.

Upper row displays current minimum light level (minimum value throughout all beams in the sensor), and lower row displays current threshold value.

Threshold value of the sensor can be adjusted between 18 (the default value at shipment from factory) and 100.

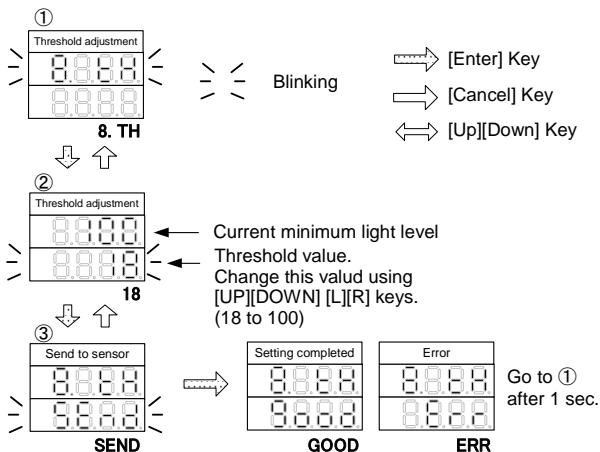

8.10 Setting initialization

<F3SN, F3SH, F3ZN>

This function returns the sensor setting to their default value.

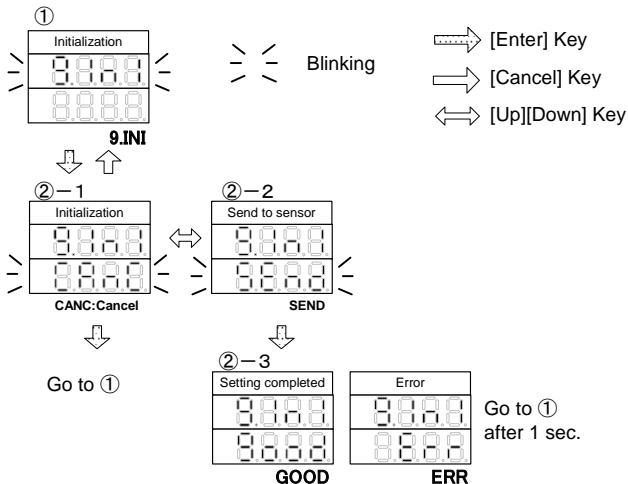

Default value of each function

Function	F3SN	F3SH	F3ZN
Fixed blanking	Invalid	—	Invalid
Floating blanking	Invalid	—	Invalid
Auxiliary output / Output2	Dark ON		
External indicator output	Light ON		
External device monitoring	Valid	—	
Start interlock	Valid	—	
Restart interlock	Valid	—	
Threshold value	—	—	18

<Note>

ID setting will not be changed by Initialization Setting.

8.11 ID setting

<F3SN, F3SH, F3ZN>

ID number can be set specific to each sensor.

The possible setting number range is between 0000 and 9999.

(Default will be 0000)

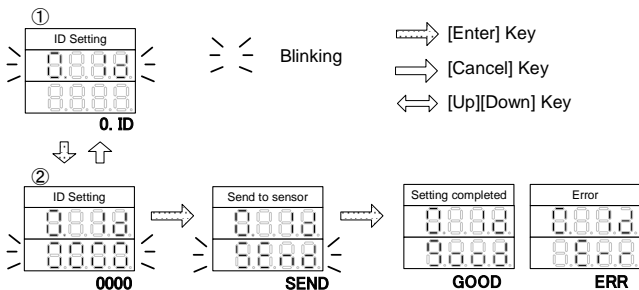

Change ID value using
[UP][DOWN] [L][R] keys.
(0000 to 9999)

Go to ①
after 1 sec.

9 COPY

This function allows you to copy settings of one sensor and transfer them to another sensor. The settings which can be changed in Monitor/Set mode, will be copied. (Including ID)

Inside the F39-MC are banks of the memory to store the date of sensor. The data will not be deleted in case of power OFF since the data in the bank is stored in EEPROM.

Bank lock setting protects data from being deleted by mistake.



The number of banks are listed below. Each bank can store setting data of one sensor.

F3SN : 1
F3SH : 1
F3ZN : 9

<Note>

1. Banks will be allocated independently to sensor models (F3SN/F3SH /F3ZN). Copying to a sensor with different model is not possible. For example, copying from F3SN to F3ZN is not possible.
2. Copying to sensor with different detection capability (or beam gap) is not possible.

Switch modes are illustrated below;

 Blinking  [UP][DOWN]Key

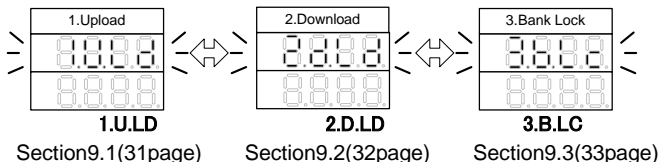

9.1 Upload (Copy Sensor data to F39-MC)

Copy the setting data of one sensor to the bank of F39-MC.
Select <1.U.Ld> and press [ENTER] key. Bank from 1 to 9 can be changed with using [UP][DOWN] keys (F3ZN only).

The illustration below shows that setting data from the sensor is stored into bank 1 of F39-MC.

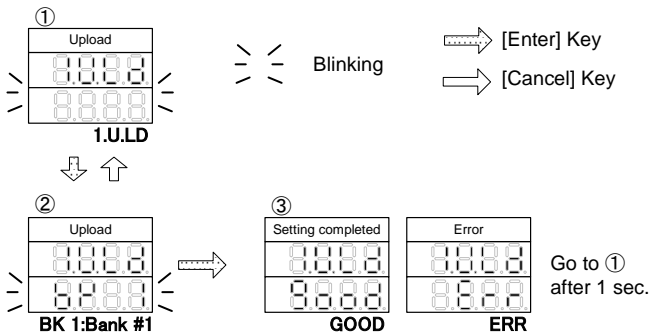

Select bank number using
[UP][DOWN] keys.

Note: F3SN/F3SH has only
Bank1

<Note>

Bank 1 for F3SN, F3SH and F3ZN are stored in different memories.

9.2 Download (Copy F39-MC data to Sensor)



WARNING

After the changing the setting of the sensor, a start-up check must be conducted. Normal operation can only be allowed after safety is confirmed.

A change of the setting can only be done under observance of laws/standards which are related to safe operation of the product.

Copy the setting data of one sensor stored in the bank of F39-MC to another sensor.

<Note>

1. Banks will be allocated independently to sensor models (F3SN/F3SH/F3ZN). Copying to sensor with different model is not possible. For example, copying from F3SN to F3ZN is not possible.
2. Copying to sensor with different detection capability (or beam gap) is not possible.

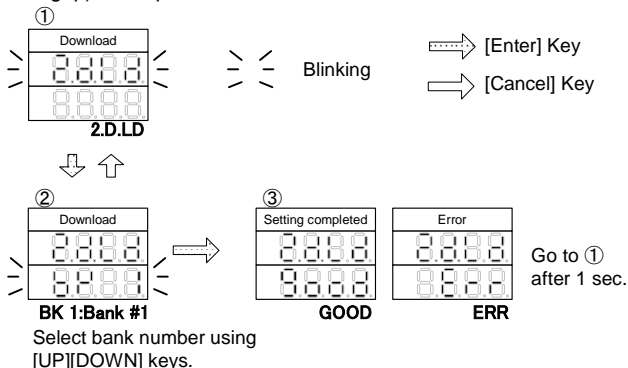

Note: F3SN/F3SH has only Bank1

9.3 Bank Lock (Prohibit overwriting to bank data)

To prohibit overwriting to a bank that has been stored with the setting data of the sensor, select this function by following means;

Select <3.b.Lc>, then press [ENTER] key to enter Bank lock mode.

Select the bank with [UP][DOWN] keys and set to either prohibit writing <Loc> or permit writing <FrEE> with [ENTER] key.

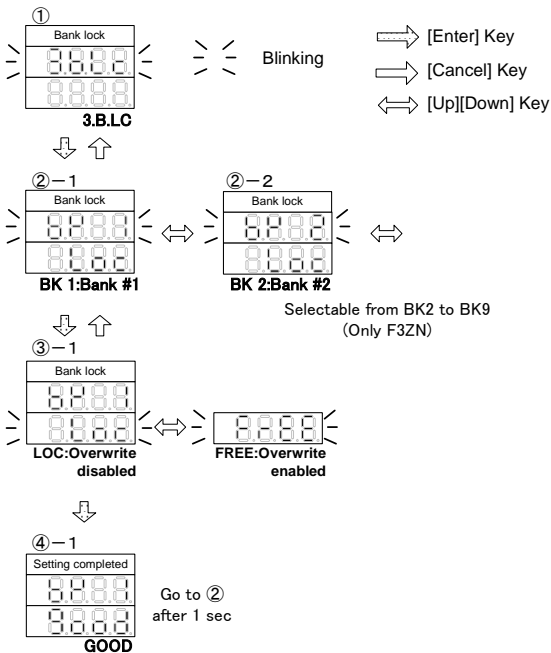

<Note>

The Locked bank cannot be selected when uploading the setting data. (The bank is not displayed.)

10 PROTECT



WARNING

F39-MC must be managed and used only by qualified persons. Operation by un-qualified persons could create a hazardous condition which may lead to a loss of safety function.



This mode enables the lock function which disallows setting changes without a password, setting limitations can also be set to restrict the changes that can be made.

<Note>

This function resides with the F39-MC and not the sensor. If the F39-MC is not protected, it could enable un-authorized persons to change the setting of the sensors.

We strongly recommend, to set "Protect" to all purchased F39-MCs.

Switching modes is illustrated below;

 Blinking  [UP][DOWN]Key

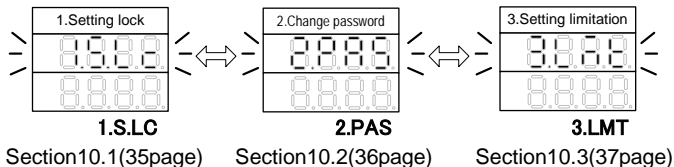

10.1 Setting lock

Prohibit setting change. Select from [Lock all sensors], [Lock only F3SN+F3SH], [Lock only F3ZN] or [Unlock all sensors].

A password (4 digit number) is required to change locked status.

When locked, the following is prohibited;

- Sending to sensor in Set/Monitor function
- Download to sensor in Copy function

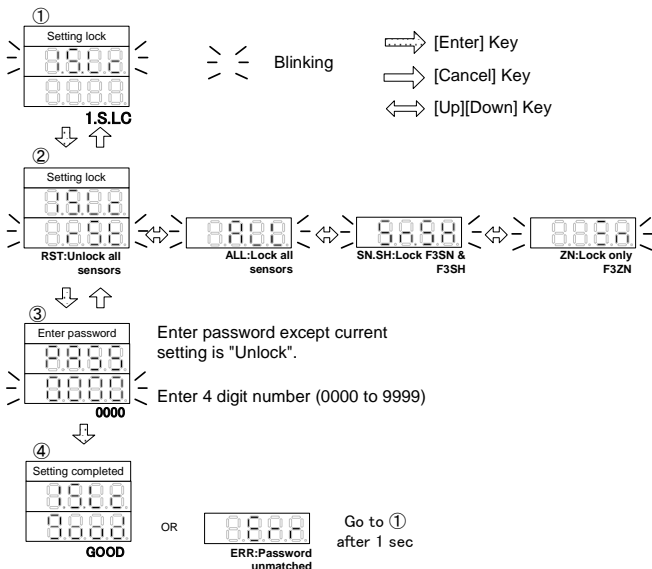

10.2 Change password

Change password (4 digit number) to release setting lock.
The default value is "0000".

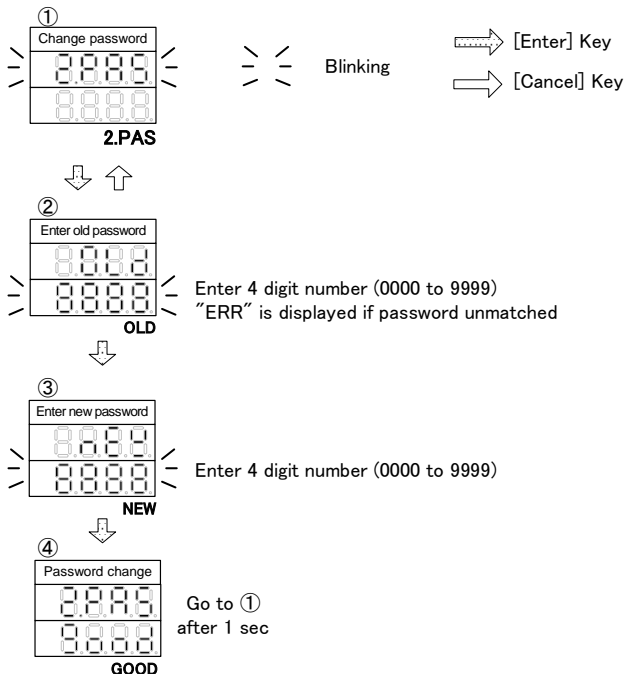

<Usage>

We strongly recommend to use with password other than "0000", and with Setting lock function. This will prevent unauthorized setting change by un-qualified person.

<Note >

Please remember changed password.
If you forget, please contact OMRON.

10.3 Setting limitation

Limit the re-settable functions in order to prevent hazardous setting by mistake.

The following can be set;

- Maximum fixed blanking zones (0 to 3 zones)
- Maximum fixed blanking beams (1 to 9 beams)
- Maximum floating blanking beams (0 to 3 beams)

The value which exceeds above set value, cannot be set to the sensor.

<How to use>

Set limitation beforehand.

This prevents hazardous settings caused by mistake.

<Description>

“Fixed blanking zone” means is number of set of beam(s) that can be blanked.

<Note >

This function does not protect against “COPY” function. (Only protected against MONITOR/SET function).

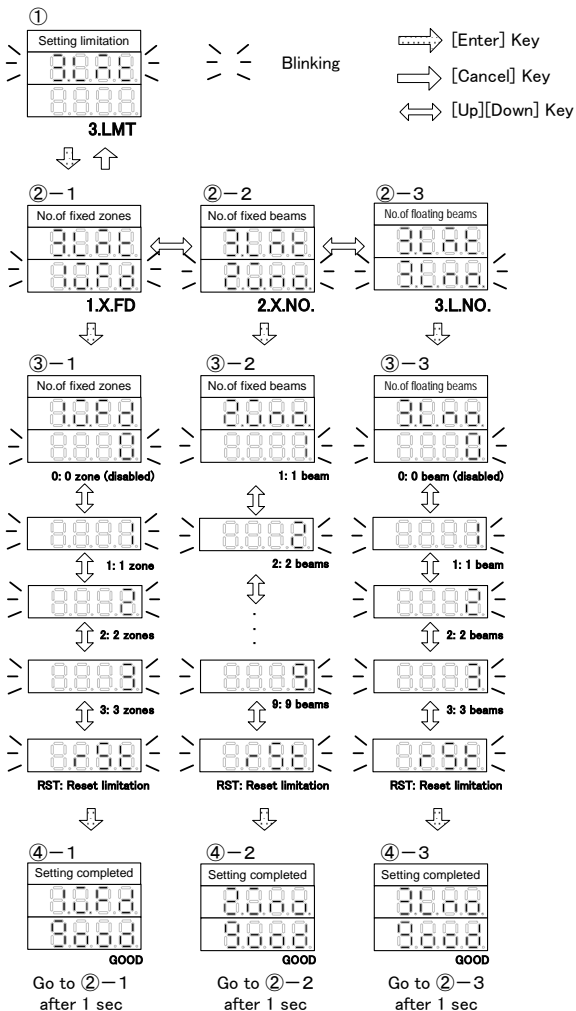

11 DISCONNECT F39-MC

After the setting has completed, be sure to disconnect cable and F39-MC before normal use.

Operation procedure;

1. Disconnect F39-MC and cable from branching connector.
2. Attach connector cap to branching connector.
(Without the connector cap, water resistance cannot be maintained.)

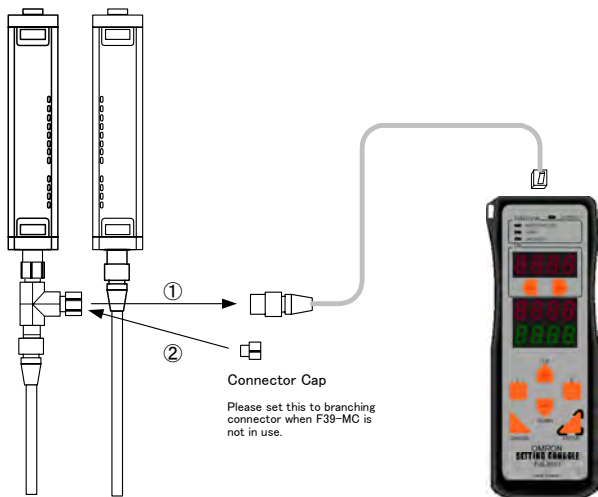

<Note>

Be sure that the machine power is OFF when disconnecting.
Disconnecting with the power ON may cause the F39-MC to malfunction.

12 ERROR CODES



“Err” may appear on the display indicating an error. Please refer to the table below for detail of the error codes.

Error code

Code	Description of error	Remedy
C001	Sensor Model error Sensors with different model are series connected.	Match all the sensor models to be connected in series.
C002	Sensor connection error Communication error occurred during connecting to sensor.	Confirm correct wiring.
C003	Communication error during connection	Confirm that there are no unloosen connector, terminals or excessive noise does not exists.
C004	EEPROM error EEPROM data has been corrupted.	Contact OMRON.
C010 and others	F39-MC destructed	Contact OMRON.

13 TROUBLESHOOTING

1. F39-MC is not powered ON.

Cause: 1. Cable or branching connector is not correctly mounted.

2. Capacity of power supply is not enough.

Remedy: 1. Mount correctly (see section 4)

2. Use power supply with enough capacity.

2. Communication connection indicator of F39-MC will not lit, or “not conn” is displayed.

Cause: 1. F39-MC has powered on after sensor has powered on.

2. Plural F39-MC is connected, or F3ZP is connected.

Remedy: 1. Power on both F39-MC and sensor at same time.

2. Connect only one F39-MC to the sensor.

3. Test indicator and/or blanking indicator of sensor flashed or lit.

Cause: Normal condition. When communicating with F39-MC, sensor becomes above condition.

Remedy: After setting completed, disconnect F39-MC and then power on sensor.

4. “none” is displayed for bank number, when uploading.

Cause: Bank lock function is set for all banks.

Remedy: Unlock the bank. (see clause 9.3)

5. Unable to send to sensor; “Loc” is displayed

Cause: 1. Setting lock or 2. Setting limitation has been set.

Remedy: Unlock above function before sending. (see clause 10.1 or 10.3)

6. “Err” is displayed when teaching

Cause: Teaching is not completed with no blocked beam.

Remedy: Teach with one or more beams blocked.

ANNEX1 INDEX

Terms		Explanation
A	Auto reset mode	[F3SN, F3SH] Interlock function is invalid in this mode. This mode can be selected with wiring interlock selection input and reset input. This mode voids all, despite the setting value of start/restart interlock function.
	Auxiliary output	[F3SN, F3SH] Non-safety related output used to display a status. This output cannot be used for the purpose of safety.
B	Blanking monitoring output (Auxiliary output, output2)	Output ON when the blanked beam becomes light reception-state, when the fixed blanking function is valid.
D	Dark ON (Auxiliary output, output2, Ext. indicator)	Output ON when sensor detects objects. In case series connected, output ON when one or more sensors detects objects.
E	External indicator output	Non-safety related output which can be connected to an optional indicator. Applicable only to the models which can be connected in series.
	External device monitoring	[F3SN, F3SH] This function can detect malfunction of external device which controls hazardous area of machine. (e.g. contact welding)
F	Fixed blanking function	[F3SN, F3ZN] Partly voids detection zone of sensor. Entrance of object into blanked detection zone does not change output condition. F3SN: Fixed blanking function becomes invalid when blanked zone becomes clear. Fixed blanking function becomes valid again, after power has reset. F3ZN: Fixed blanking function is valid even after blanked zone becomes light reception-state.
	Floating blanking function	[F3SN, F3ZN] This function allows the output to remain ON when beams of the sensor are interrupted anywhere in the field. Floating can be set for 1 to 3 beams.
I	ID	Indicates numbers 0000 to 9999 which can be set specific to each sensor.
L	Light diagnosis (Auxiliary output, output2, Ext. indicator)	Output ON when unstable condition lasts for 3 seconds or more. Can detect deterioration of optical performance caused by dirty optical surface, displacement of beams or deterioration of LED. "Unstable condition" indicates that the light level remains within +/-20% of threshold value.
	Light ON (Auxiliary output, output2, Ext. indicator)	Output ON when detection area is clear. In case series connected, output ON when all sensors' detection area is clear.
	Lockout output (Auxiliary output, output2, Ext. indicator)	Output ON when the sensor is in lockout condition (i.e. mode which detects abnormality and stop the sensing function).

Terms		Explanation
M	Manual reset mode	[F3SN, F3SH] Interlock function is valid in this mode. This mode can be selected by wiring interlock selection input and reset input.
	Max. number of fixed beams (Protect)	Maximum number of beams which can be blanked by fixed blanking function. Beams exceeding this number cannot be blanked.
	Max. number of fixed zones (Protect)	Maximum number of set of beam(s) which can be blanked by fixed blanking function. One zone is defined as blanked beam(s) which is surrounded by not-blanked beams.
	Max. number of floating beams (Protect)	Maximum number of beams which can be set by floating blanking function. Floating beams exceeding this number cannot be set.
O	Outermost beam invalid (Floating blanking)	This mode excludes outermost beams from floating blanking. When this mode is valid, the output will turn OFF if one of the outermost beams is blocked, even if floating blanking is active.
	Outermost beam monitoring output (Auxiliary output, output2)	Output ON when only outermost beam(s) is/are interrupted.
	Output2	[F3ZN] Output of F3ZN used to display a status.
R	Restart interlock function	[F3SN, F3SH] Outputs remain in the OFF-state (i.e. interlock state) when sensor is interrupted. Interlock state can be released by a manual reset when there are no obstructions in the detection zone. This function is valid only when using manual reset mode.
S	Sequential beam mode (Floating blanking)	If this mode is valid, output becomes OFF when consecutive blocked beams exceeds floating beams. If this mode is invalid, output becomes OFF when sum of blocked beams exceeds floating beams.
	Specified Beam (Auxiliary output, output2)	Output ON when any of specified beams are blocked. When this signal is selected, it is necessary to specify beam.
	Start interlock function	[F3SN, F3SH] Outputs remain in the OFF-state (i.e. Interlock state) after power ON. Interlock state can be released by a manual reset when there are no obstructions in the detection zone. This function is valid only when using manual reset mode.

ANNEX2 FUNCTION LIST (according to sensor type)

F3SN

Function	Sensor CH	Mode display (Top row)		Mode display (Bottom row)
SET/ MONITOR	ALL 1~3	Fixed blanking	Function	Valid/Invalid
			Teach	Teaching/Clear
			Manual	Valid/Invalid(Set each beam)
	ALL		-	Send to sensor
	ALL 1~3	Floating blanking	Function	Valid/Invalid
			Floating Beam	1/2/3/Clear
			Sequential beam	Valid/Invalid
			Outermost beam invalid	Valid/Invalid
	ALL		-	Send to sensor
	ALL	Auxiliary output	Setting value	L-on/D-on/Light diagnosis/ Lockout/Outermost beam/ Specified beam/Blanking
			-	Send to sensor
		External indicator output	Setting value	L-on/D-on/Light diagnosis/ Lockout
			-	Send to sensor
		External device monitoring	Function	Valid/Invalid
			Setting time	100 to 600ms ; every 5ms
			-	Send to sensor
		Start interlock	Function	Valid/Invalid
			-	Send to sensor
Restart interlock	Function	Valid/Invalid		
	-	Send to sensor		
Initialization		Cancel/Send to sensor		
ID setting	Setting value	0000 to 9999		
	-	Send to sensor		
COPY	1~3	Upload	Bank number	
	1~3	Download	Bank number	
	-	Bank lock	Bank number LOCK/FREE	
PROTECT	-	Setting lock	Lock object	All / Only F3SN+F3SH / Only F3ZN / Clear
			Input password	Input 4 digit number
	-	Change password	Old password	Input 4 digit number
			New password	Input 4 digit number
	-	Setting limitation	No. of fixed zones	Clear, 0 to 3
			Max. no. of Fixed beams	Clear, 1 to 9
Max. no. of floating beams			Clear, 0 to 3	

F3SH

Function	Sensor CH	Mode display (Top row)		Mode display (Bottom row)
SET/ MONITOR	ALL	Auxiliary output	Setting value	L-on/D-on/Light diagnosis/ Lockout/Outermost beam/ Specified beam
			-	Send to sensor
		External indicator output	Setting value	L-on/D-on/Light diagnosis/ Lockout
			-	Send to sensor
		External device monitoring	Function	Valid/Invalid
			Setting time	100 to 600ms ; every 5ms
			-	Send to sensor
		Start interlock	Function	Valid/Invalid
			-	Send to sensor
		Restart interlock	Function	Valid/Invalid
-	Send to sensor			
Initialization		Cancel/Send to sensor		
ID setting	Setting value	0000 to 9999		
	-	Send to sensor		
COPY	1~3	Upload		Bank number
	1~3	Download		Bank number
	-	Bank lock	Bank number	LOCK/FREE
PROTECT	-	Setting lock	Lock object	All / Only F3SN+F3SH / Only F3ZN / Clear
			Input password	Input 4 digit number
	-	Change password	Old password	Input 4 digit number
			New password	Input 4 digit number
	-	Setting limitation	No. of fixed zones	Clear, 0 to 3
			Max. no. of Fixed beams	Clear, 1 to 9
Max. no. of floating beams			Clear, 0 to 3	

F3ZN

Function	Sens or CH	Mode display (Top row)		Mode display (Bottom row)
SET/ MONITOR	ALL 1~3	Fixed blanking	Function	Valid/Invalid
			Teach	Teaching/Clear
			Manual	Valid/Invalid(Set each beam)
	ALL		-	Send to sensor
	ALL 1~3	Floating blanking	Function	Valid/Invalid
			Floating Beam	1/2/3/Clear
			Sequential beam	Valid/Invalid
			Outermost beam invalid	Valid/Invalid
	ALL		-	Send to sensor
	ALL	Output2	Setting value	L-on/D-on/Light diagnosis/ Lockout/Outermost beam/ Specified beam/Blanking
			-	Send to sensor
		External indicator output	Setting value	L-on/D-on/Light diagnosis/ Lockout
			-	Send to sensor
		Threshold adjustment	Min. light level	Threshold value
		-	-	Send to sensor
		Initialization		Cancel/Send to sensor
ID setting		Setting value	0000 to 9999	
	-	Send to sensor		
COPY	1 to 3	Upload	Bank number	
	1 to 3	Download	Bank number	
	-	Bank lock	Bank number LOCK/FREE	
PROTECT	-	Setting lock	Lock object	All / Only F3SN+F3SH / Only F3ZN / Clear
			Input password	Input 4 digit number
	-	Change password	Old password	Input 4 digit number
			New password	Input 4 digit number
	-	Setting limitation	No. of fixed zones	Clear, 0 to 3
			Max. no. of Fixed beams	Clear, 1 to 9
Max. no. of floating beams			Clear, 0 to 3	

ANNEX3 FUNCTION SETTING CARD

F3SN

FUNCTION		SETTING VALUE
Fixed blanking	Function	Valid/Invalid
	Blanked beam	_____ (List selected beams)
Floating blanking	Function	Valid/Invalid
	Floating Beam	1/2/3/Clear
	Sequential beam	Valid/Invalid
	Outermost beam invalid	Valid/Invalid
Auxiliary output	Setting value	L-on/D-on/Light diagnosis/ Lockout/ Outermost beam/ Specified beam/Blanking
Ext. indicator output	Setting value	L-on/D-on/Light diagnosis/ Lockout
External device monitoring	Function	Valid/Invalid
	Acceptable delay time	_____ ms (100 to 600ms)
Start interlock	Function	Valid/Invalid
Restart interlock	Function	Valid/Invalid
ID setting	Setting value	_____ (0000 to 9999)

F3SH

FUNCTION		SETTING VALUE
Auxiliary output	Setting value	L-on/D-on/Light diagnosis/ Lockout/ Outermost beam/ Specified beam
Ext. indicator output	Setting value	L-on/D-on/Light diagnosis/ Lockout
External device monitoring	Function	Valid/Invalid
	Acceptable delay time	_____ ms (100 to 600ms)
Start interlock	Function	Valid/Invalid
Restart interlock	Function	Valid/Invalid
ID setting	Setting value	_____ (0000 to 9999)

F3ZN

FUNCTION		SETTING VALUE
Fixed blanking	Function	Valid/Invalid
	Blanked beam	_____ (List selected beams)
Floating blanking	Function	Valid/Invalid
	Floating Beam	1/2/3/Clear
	Sequential beam	Valid/Invalid
	Outermost beam invalid	Valid/Invalid
Output2	Setting value	L-on/D-on/Light diagnosis/ Lockout/ Outermost beam/ Specified beam/Blanking
Ext. indicator output	Setting value	L-on/D-on/Light diagnosis/ Lockout
Threshold Adj.	Setting value	_____ (18 to 100)
ID setting	Setting value	_____ (0000 to 9999)