

F3S-TGR-SB4-KxC

F3S-TGR-SB2-KxC

Type 4 Safety Light Curtain
Type 2 Safety Light Curtain

USER'S MANUAL

OMRON

Introduction

INTRODUCTION

This instruction Manual describes the F3S-TGR-SBx-KxC Safety Light Curtain (SLC).

General Safety Requirements

Always heed the following points when using the F3S-TGR-SBx-KxC:

- Read this manual thoroughly to understand and make good use of the descriptions before installing and operating the product.
- A qualified person should conduct a risk assessment on the machine, and determine the suitability of this product before installation.
- Keep this Manual at the place where the operator can refer to it whenever necessary.
- Do not open the housing or make any unauthorised modifications.
- The power supply must be disconnected before proceeding with any external intervention.

Regulation and Standards

1. The F3S-TGR-SBx-KxC safety light curtains are electro-sensitive protective equipment (ESPE) in accordance with European Union (EU) Machinery Directive Annex IV, B, Safety Components and Item 1.
2. The F3S-TGR-SBx-KxC complies with the following regulations and standards:
 - (1) EU regulations
 - Machinery Directive: Directive 98/37/EC
 - EMC Directive: Directive 89/336/EEC
 - (2) European standards: EN61496-1, prEN61496-2
3. The F3S-TGR-SBx-KxC received the following approvals from notified body TÜV Product Service:
 - EC Type-Examination in accordance with the EU Machinery Directive
 - TYPE 2 and 4 ESPE (EN61496-1),
 - TYPE 2 and 4 AOPD (prEN61496-2)
 - Certificate of a Notified Body for EMC

READ AND UNDERSTAND THIS MANUAL

Please read and understand this manual before storing, installing, operating, maintaining, or disposing of the product.

Please consult your TECHNO GR representative if you have any questions or comments.

WARRANTY

TECHNO GR's exclusive warranty is that the products are free from defects in materials and workmanship for a period of one year (or other period if specified) from date of sale by TECHNO GR.

TECHNO GR MAKES NO WARRANTY OR REPRESENTATION, EXPRESS OR IMPLIED, REGARDING NONINFRINGEMENT, MERCHANTABILITY, OR FITNESS FOR PARTICULAR PURPOSE OF THE PRODUCTS.

ANY BUYER OR USER ACKNOWLEDGES THAT THE BUYER OR USER ALONE HAS DETERMINED THAT THE PRODUCTS WILL SUITABLY MEET THE REQUIREMENTS OF THEIR INTENDED USE.

TECHNO GR DISCLAIMS ALL OTHER WARRANTIES, EXPRESS OR IMPLIED.

LIMITATION OF LIABILITY

TECHNO GR SHALL NOT BE RESPONSIBLE FOR SPECIAL, INDIRECT, OR CONSEQUENTIAL DAMAGES, LOSS OF PROFITS OR COMMERCIAL LOSS IN ANY WAY CONNECTED WITH THE PRODUCTS, WHETHER SUCH CLAIM IS

BASED ON CONTRACT, WARRANTY, NEGLIGENCE, OR STRICT LIABILITY.

In no event shall responsibility of TECHNO GR for any act exceed the individual price of the product on which liability is asserted.

IN NO EVENT SHALL TECHNO GR BE RESPONSIBLE FOR WARRANTY, REPAIR, OR OTHER CLAIMS REGARDING THE PRODUCTS UNLESS TECHNO GR'S ANALYSIS CONFIRMS THAT THE PRODUCTS WERE PROPERLY HANDLED, STORED, INSTALLED, AND MAINTAINED AND NOT SUBJECT TO CONTAMINATION, ABUSE, MISUSE, OR INAPPROPRIATE MODIFICATION OR REPAIR.

SUITABILITY FOR USE

TECHNO GR shall not be responsible for conformity with any standards, codes, or regulations that apply to the combination of products in the customer's application or use of the product.

At the customer's request, TECHNO GR will provide applicable third party certification documents identifying ratings and limitations of use that apply to the products.

This information by itself is not sufficient for a complete determination of the suitability of the products in combination with the end product, machine, system, or other application or use.

The following are some examples of applications for which particular attention must be given. This is not intended to be an exhaustive list of all possible uses of the products, nor is it intended to imply that the uses listed may be suitable for the products:

- Outdoor use, involving potential chemical contamination or electrical interference or conditions or use not described in this document.
- Nuclear energy control systems, combustion systems, railroad systems, aviation systems, medical equipment, amusement machines, vehicles, and installations subject to separate industry or government regulations.
- Systems, machines, and equipment that could present a risk to life or property.

Please know and observe all prohibitions of use applicable to the products.

NEVER USE THE PRODUCTS FOR AN APPLICATION INVOLVING SERIOUS RISK TO LIFE OR PROPERTY WITHOUT ENSURING THAT THE SYSTEM AS A WHOLE HAS BEEN DESIGNED TO ADDRESS THE RISKS, AND THAT THE TECHNO GR PRODUCT IS PROPERLY RATED AND INSTALLED FOR THE INTENDED USE WITHIN THE OVERALL EQUIPMENT OR SYSTEM.

Note: Some specifications of the products may be changed without any notice.

Special model numbers may be assigned to fix or establish key specifications for your application on your request.

Please consult with your TECHNO GR representative at any time to confirm actual specifications of purchased products.

DEFINITION OF SYMBOLS

Information in this manual that is of particular importance can be identified as follows;



WARNING indicates a potentially hazardous situation, which, if not avoided, will result in minor or moderate injury, or may result in serious injury or death. Additionally there may be significant property damage.



CAUTION indicates a potentially hazardous situation, which, if not avoided, will occasionally result in minor or moderate injury, or result in physical damage to property.



NOTICE is used to emphasise essential information.

MANUFACTURER: TECHNO-GR s.r.l.
via Torino, 13/15
10046 Poirino (TO) - ITALY
Tel. +39 011 9452041
FAX +39 011 9452090
E-Mail info_technogr@eu.omron.com
WWW www.technogr.com

USER'S MANUAL: Version 5.1 dated 29-3-2006

INDEX

<i>Section</i>		<i>Page</i>
1	Operation	7
2	Precautions and criteria for installation	8
	2-1 Calculation of the minimum distance for installation	8
	2-2 Reflecting surfaces.	9
3	Mechanical Assembly	12
4	Connections	13
	4-1 Reference for cables.	13
	4-2 Notes on connections	13
5	Alignment Procedure	14
6	Operating procedures	15
	6-1 Setting the internal DIP-Switches	15
	6-1-1 Selection of reset mode	15
7	Muting and override functions	16
	7-1 General information	16
	7-2 Muting function.	16
	7-3 Partial muting configuration	17
	7-4 Criteria for installation	18
	7-5 Timing constants (muting function)	21
	7-6 Timing constraints (for SLCs with postfix "-MTL" at the ordering code)	21
	7-7 Override	22
	7-7-1 Enabling the Override Function	22
8	LED diagnostics	23
	8-1 LED's Description	23
9	Routine controls and maintenance	25
10	Final checks after installation	26
11	General information and useful data	28
12	Technical specifications	29
13	Dimensions	31
14	Note	32

The **Safety Light Curtain (SLC)** is made up of one active side with transmitter and receiver optical elements called the transceiver and one completely passive side, with a mirror system.

The operator has a multifunction pushbutton, which is used for the following:

- **TEST:** If pressed during normal operation, it checks if all of the system, comprising of the SLC and the machine is working. Pressing the TEST button (opening the contact) basically simulates the interruption of one or more safety beams and it is possible to check that the machinery stops in the correct time and configuration.
 - **RESTART:** If pressed after an intervention by the SLC, (manual reset condition) the system will be reset.
 - **ALIGNMENT:** If the button is pressed when there is no power supply to the SLC and then power is restored, whilst the button is being pressed, it enters alignment mode, i.e. it provides an indication of the alignment position of the unit by means of two yellow LEDs.
 - **OVERRIDE:** (only present if the muting function is operational) if the button is pressed within 5 seconds of switching on and it is kept pressed for at least 5 seconds, the SLC will close the safety outputs if the beams are interrupted. This condition stops as soon as the button is released or automatically after 120 seconds.
1. **Automatic reset:** After the SLC has detected an object, it returns to normal operation as soon as the object is removed.
 2. **Manual reset:** Normal operating mode is only restored after the object has been removed and the reset button has been pressed.

To enable the *muting* function, the LMS muting indicator must be connected **when the SLC is not connected to the power supply**, as shown in section 6, and then the SLC's power supply must be restored. To disable the muting function, the LMS muting indicator must be disconnected **when the SLC is not connected to the power supply**, and then the SLC's power supply restored.

Please remember that by enabling/disabling the muting function the override function is automatically enabled/disabled.

The outputs are PNP type.

Should the load to be controlled have alternating current or require more than 250 mA consumption, it is necessary to use an external safety relay module.

Section 2: Precautions and criteria for installation

The area where the SLC is to be installed must be compatible with the SLC's technical specifications. The temperature of the environment, interference caused by electromagnetic disturbance and sources of light and such like, should be assessed a competent person. Please contact the manufacturer for any information not contained in this manual.

2-1 Calculation of the minimum distance for installation

The safety distance 'S' must guarantee that the operator cannot reach the danger zone before the machinery with the moving parts has stopped. The formula to calculate the safety distance for multi-beam SLCs is as follows:

$$S = (K * T) + C$$

S = safety distance.

T = T1 + T2

where T1 = machinery's response time in seconds.

T2 = SLC's response time in seconds.

K = 1600 mm/s (approach speed of the body to the danger zone).

C = 850 mm

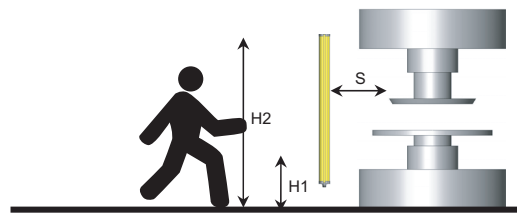

S = safety distance.

H1 = the bottom optical beam must not have a height above 400 mm.

H2 = the top optical beam must not be below 900 mm.

Number of beams	Heights above the reference plane, e.g. ground in mm
4 (F3S-TGR-SBx-K4C)	300, 600, 900, 1200
3 (F3S-TGR-SBx-K3C)	300, 700, 1100
2 (F3S-TGR-SBx-K2C)	400, 900

Reference from EN999

 Do not use F3S-TGR-SBx-KxC series in horizontal position.

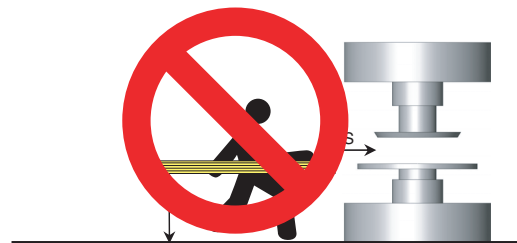

2-2 Reflecting surfaces



Be sure to install the SLC to minimize the effect of reflection from nearby surfaces. Serious injuries can result if these effects are not taken into consideration.

Should there be any reflecting surfaces, the distance must be sufficient to safeguard against passive reflections.

The distance can be calculated following the table below:

where 'D' and 'L' are expressed in m

Reflecting surface

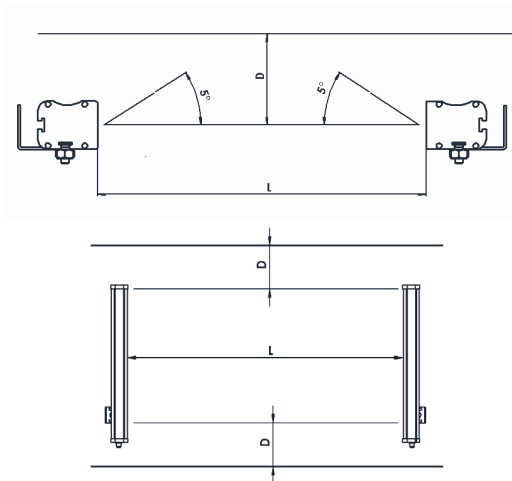

Model	L distance between SLCs	Minimum permitted installation distance D
F3S-TGR-SB2-KxC	0.5 to 3 m	0.26 m
	Over 3 m	$L/2 \times \tan 5^\circ = L/2 \times 0.088$ (m)
F3S-TGR-SB4-KxC	0.5 to 3 m	0.13 m
	Over 3 m	$L/2 \times \tan 5^\circ = L/2 \times 0.044$ (m)

If several SLCs are used, care must be taken that each SLC does not interfere with the ones nearby; please install as follows:

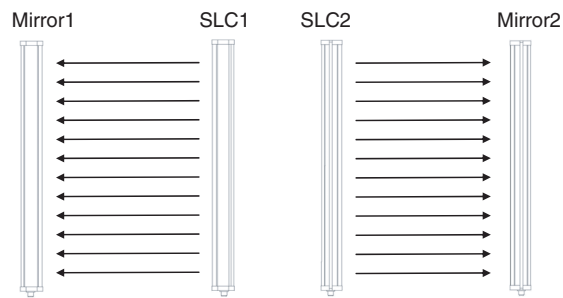

Install the SLC so that they emit in the opposite directions (Staggered)

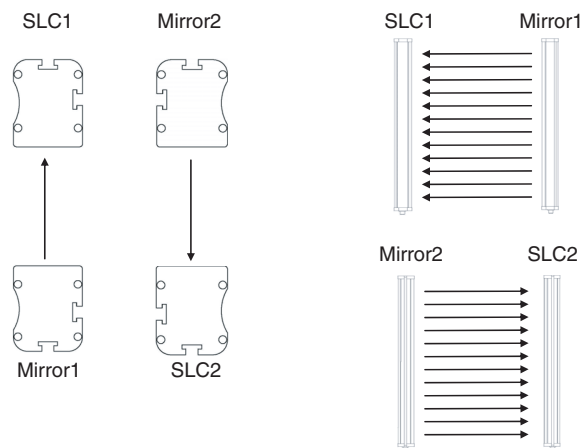

All these installation will prevent mutual interference between SLC.



Insert a non-transparent wall if it is not possible to connect the SLC as shown previously.

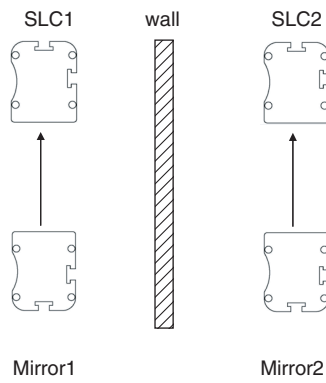
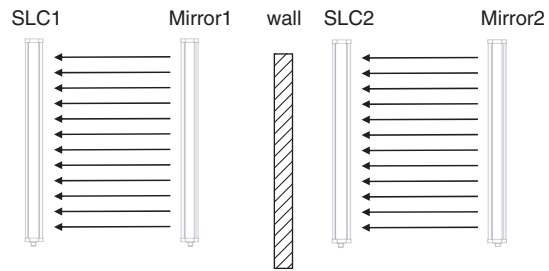

The two bars **must** be mounted symmetrically as shown in the picture:

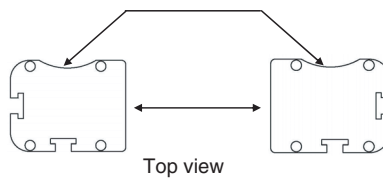

Section 3: Mechanical Assembly

Use the appropriate brackets provided to complete the mechanical assembly.

The securing brackets nuts ① slide in the container's grooves so the brackets ② can be placed at an equal distance from each other.

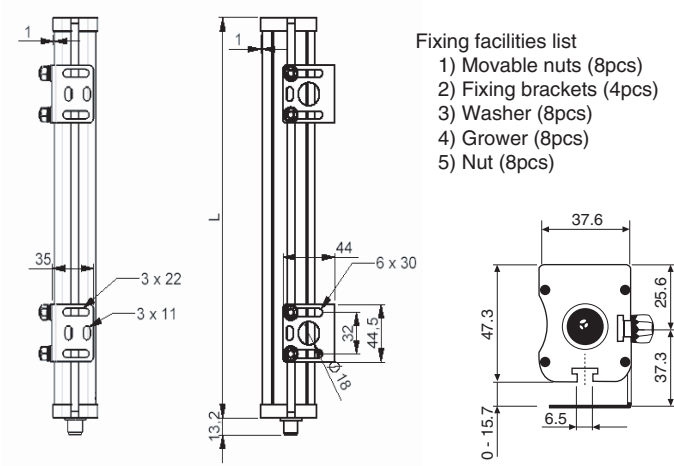
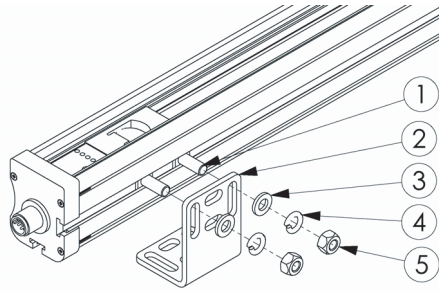

- Fixing facilities list
- 1) Movable nuts (8pcs)
 - 2) Fixing brackets (4pcs)
 - 3) Washer (8pcs)
 - 4) Grower (8pcs)
 - 5) Nut (8pcs)

4-1 Reference for cables

The test connection must always be executed with a N.C. button or connected to an automatic device, such as a PLC.

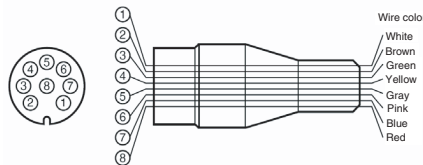
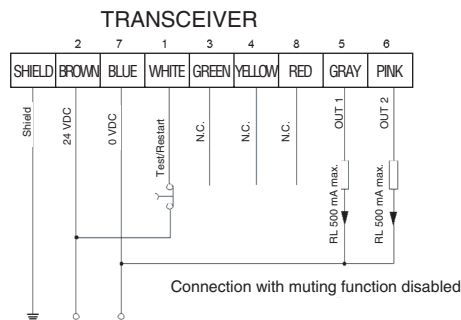
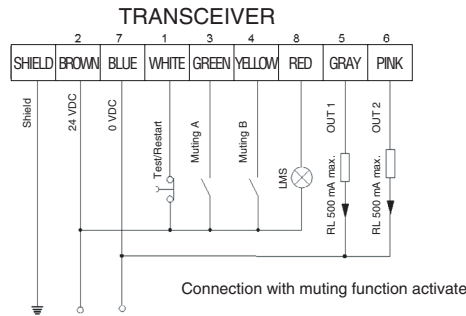

4-2 Notes on connections



- The transformer needed to power the system must comply with standard EN 60742 (dual isolation), or with equivalent isolation, e.g. VDE 0551.
- The control unit must be protected with an external fuse, whose rated breaking current must be 1 A.
- The TEST/RESTART button must be located so that the operator can see the protected area when restarting, testing or overriding.
- The external illuminated indicator for muting override enabled must be located so that it can be seen from all sides of operation.
- Read the section on the muting function and its use before locating the sensors for the activation of this function.
- Check that the load does not absorb current in excess of 250 mA for each OSSD; in this case a protection device will intervene to limit the maximum current. If loads with currents in excess of 250 mA for each OSSD or alternating current are to be controlled, please connect an external safety relay module.
- Muting input A and Muting input B can be provided by mechanical switch, photoelectric sensors, proximities switch, with closed contact in the presence of the object to be detected.
- The test connection must always be executed with a N.C. button or connected to an automatic device, such as a PLC.

Section 5: Alignment Procedure

After completing correct mechanical assembly and connections, as described in the previous sections, the SLC should be aligned as follows:

- Disconnect the SLC's power supply.
- Open the test/restart contact.
- Restore the SLC's power supply.
- Adjust the direction of the SLC by moving the transceiver or the mirror. The 2 yellow LEDs located on the transceiver will both be lit when the SLC is aligned correctly. In addition also the green guard LED will switch on and the red break LED will switch off
- After aligning the SLC, secure the bolts firmly.
- Disconnect the power supply.
- Restore the SLC's power supply (with the test contact closed); it will enter operating mode.
- Complete all the tests described in section 9 (final checks) and those required for routine maintenance (section 10).

6-1 Setting the internal DIP-Switches

- Disconnect the SLC's power supply and remove the connector side of the transceiver, so that you can access the two banks four-way dip-switches located there.
- Use a suitably sized screwdriver to set the dip-switches as per the required configuration according to the following tables.

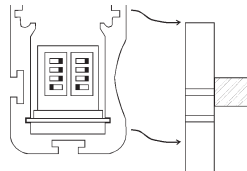

6-1-1 Selection of reset mode

Single switch number 4	Reset
OFF	Manual
ON	Automatic (Default setting)

! ATTENTION

In every transceiver unit there are two separate dip-switch banks. The two banks must be set in the same way to get a valid configuration.

Single switch number 3	No function
OFF	DEFAULT SETTING
ON	NOT ALLOWED

Dip switches number 1 and 2, act on the partial muting configuration. See "Partial muting configuration" chapter 7.3.

Section 7: Muting and override functions

7-1 General information

The muting and override functions enable the SLC to be bypassed for operational requirements. As required by current standards, the SLC is provided with inputs for the activation of these functions. It should however be remembered that these functions basically override the system and they should therefore be used with due care.

7-2 Muting function

As mentioned in the introduction, the muting function can be enabled with any SLC by simply connecting the LMS muting indicator when the SLC is switched off.

The presence of this indicator is recognised when the SLC is switched on. If its presence is detected, the SLC will enable the muting function and if it is not present the SLC will ignore any request for muting. **It is important to note that if the muting indicator is connected when the SLC is already connected to the power supply, it will not be recognised and the muting function will not be enabled.** Once enabled, if the LMS muting indicator develops a fault or is removed without first disconnecting the SLC's power supply, it will signal an error with the muting light, as described in section 10.

To disable the muting function, the power supply must be turned on without the LMS muting indicator connected.

In brief: this function, present on all SLC s, is enabled and disabled by means of the following simple procedure:

- Disconnect the SLC's power supply.
- Connect the appropriate LMS muting indicator and the muting sensors (see section 6)
- Restore the SLC's power supply.

Bypass the muting function as follows.

- Disconnect the SLC's power supply.
- Disconnect the LMS muting indicator and the muting sensors (see section 6)
- Restore the SLC's power supply.

7-3 Partial muting configuration

This feature is available only on the F3S-TGR-SBx-K3C and F3S-TGR-SBx-K4C models. It gives the users the opportunity to mute only half of the light curtain. The other half remains active.

The configuration of this function is done by setting the internal dip switches **1 & 2**.

For correct configuration and identification of dip switch and bypassed optics refer to the following drawing and table.

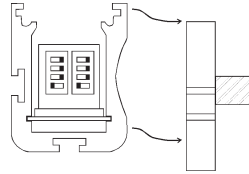
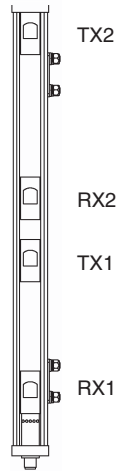

Dip-Switch		Muted Beams
1	2	
OFF	OFF	All 4 optics (Default setting)
OFF	ON	Only TX1 - RX1
ON	OFF	Only TX2 - RX2
ON	ON	NOT ALLOWED

CONNECTOR SIDE.

7-4 Criteria for installation

Take adequate care when installing the muting sensors to prevent undesired requests for muting:

1. Wiring must be done correctly.
2. The muting sensors must recognise the whole length of the material (i.e. pallets, vehicles...).
3. The sensors must be arranged so that the material is also recognised if it has to be lifted for processing.
4. The effect of various transportation speeds in the field of muting on the overall duration of muting must be taken into account, if any.
5. All the safety photocells and muting sensors must be arranged so that the previous material clears the last muting sensor before the new material reaches the first sensors

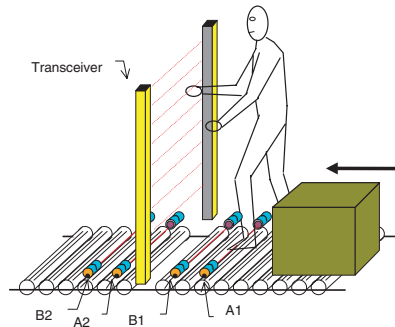

Example of conveyor protection installation, which must allow a box to pass through but not a person. The SLC S is connected to the control panel, and **A1, A2, B1 and B2** are sensors used to enable muting. The contacts for these sensors are controlled on the transceiver unit.

Sensors **A1, A2, B1 and B2** can be optical, mechanical or proximity sensors etc., with closed contact in the presence of the object to be detected.

The following drawings show several examples of configurations with the use of the muting function:

Application with four sensors - 'Bi directional muting'

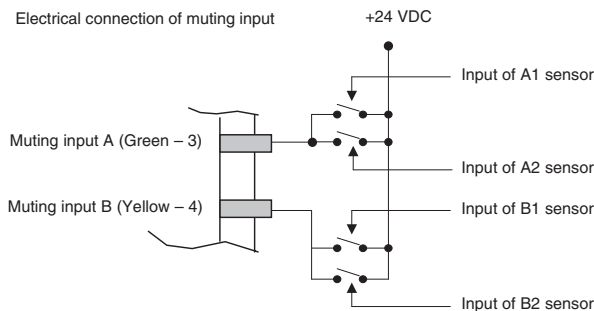
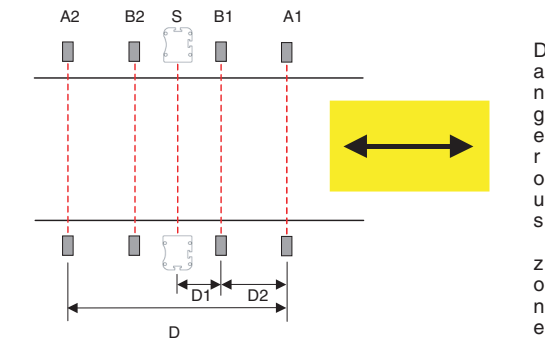

Application with four sensors and single direction for material exit:

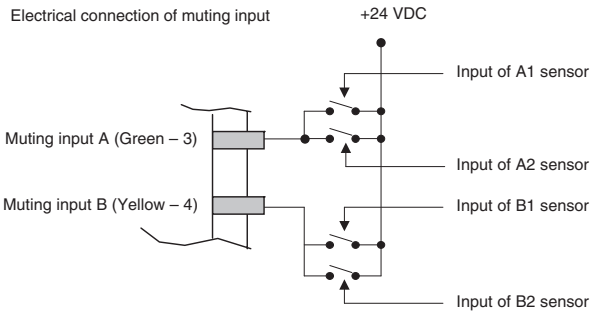
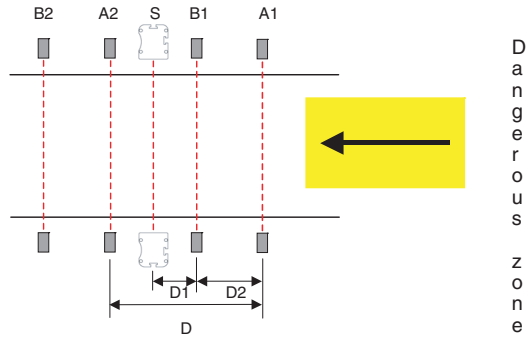

Application with two sensors and single direction for material exit:



This muting activation sequence is only available for SLCs with postfix "-MTL" at the ordering code

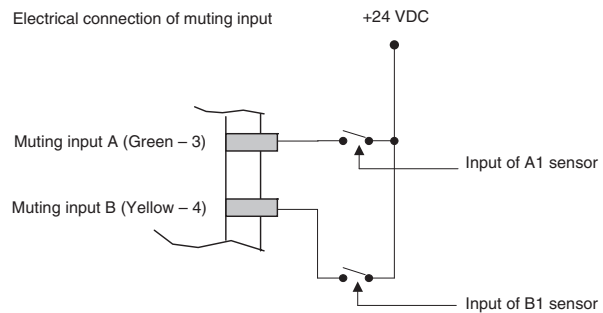
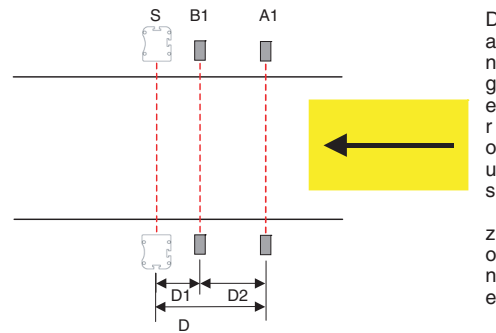

Where:

D: minimum dimension of package that can cross the SLC.

D1: distance between muting actuator B and SLC.

It MUST be as short as possible.

Minimum distance allowable depends on the speed of conveyour, the response time of SLC and response time of muting actuator.

D2: Distance between muting actuator A and muting actuator B.

It must be > 250mm

It also depends on the conveyour speed:

$$d_{\max} [\text{cm}] = v[\text{m/s}] * 3[\text{s}] * 100 > 25$$

It is necessary that this distance does not allow both sensors to be activated and thus muting if a person goes through by accident.

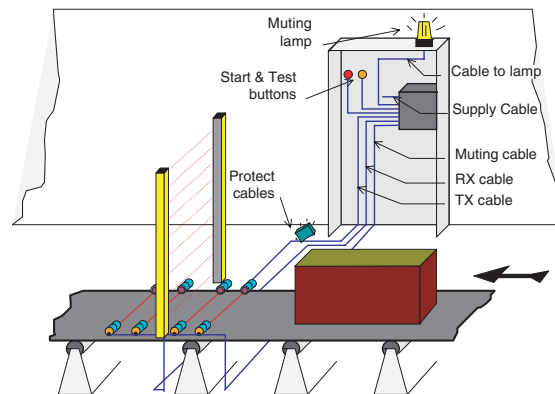

- The TEST/RESTART button must be located so that the operator can see the protected area when restarting, testing or overriding.
- The external illuminated indicator for muting override enabled must be located so that it can be seen from all sides of operation.
- If the muting sensors are installed very close to the SLC, care must be taken that the receivers of the sensors are mounted on the mirror side of the SLC in order to avoid interference.
- The system is protected against the possibility of faults due to damage to the wires; however we recommend laying the cables for all connections in order to avoid damage to the connection cables.

7-5 Timing constants (muting function)

- The muting request must take place with the correct timing sequence: the Muting A input must be enabled first and then the Muting B input. The request for the latter must be made within a maximum of 3 seconds and not before 30 ms (T_m) after enabling Muting A input. Otherwise the muting function will not be enabled. An incorrect sequence on the muting inputs will not start the muting process.
- Muting status can be maintained for an unlimited period of time as long as the muting signals are valid.

Timing chart

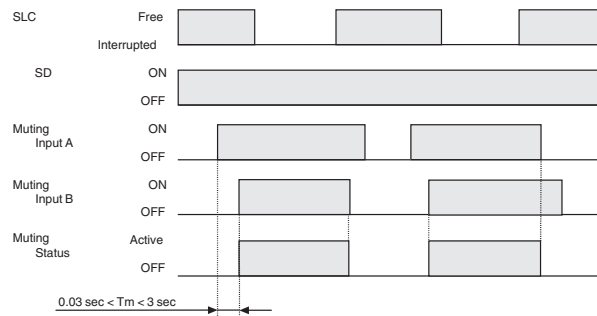

A muting request cannot be made if the SLC outputs are open, that is to say when the beams have been interrupted.

7-6 Timing constraints (for SLCs with postfix "-MTL" at the ordering code)

- The muting request must take place with the correct timing sequence: the Muting A input must be enabled first and then the Muting B input. The request for the latter must be made within a maximum of 3 seconds and not before 30 ms after the enabling of the Muting A input. Otherwise the muting function will not be enabled. An incorrect sequence on the muting inputs will not start the muting process.
- There are 5 seconds maximum from the activation of muting to the package entrance in the protected area by interrupting the SLC. If this time is exceeded, muting function will stop immediately.
- As long as a package interrupts the protected area (at least one beam), the muting function is maintained.
- Muting status can be maintained for an unlimited period of time as long as the muting signals are valid.

Timing chart

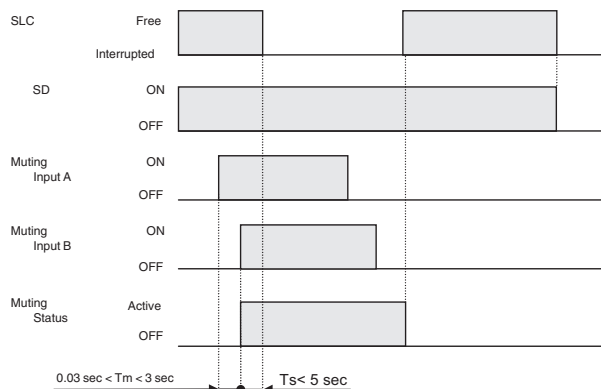

7-7

Override

This function makes it **possible to override or bypass the system**. It is used to start up the **machine after the material has interrupted one or more of the SLC beams and to free the protected area from any material that is present in front of the SLC**,

If a pallet has stopped in front of the protected area, it will not be possible to restart the conveyor belt because the SLC detects one or more beams have been interrupted and therefore will not close the outputs; therefore the **protected area** cannot be cleared.

However, it can be cleared if the override function is enabled.

This function can be used for all SLCs with the **LMS muting indicator** connected, as described in section 3.

7-7-1

Enabling the Override Function

- Switch the appliance off.
- Switch it on again and press the test/restart button within 5 seconds, keeping it pressed for at least 5 seconds.
- The override function is now enabled. The LMS muting indicator flashes to signal the exclusion of the SLC.
- The maximum duration of the override function is 120 seconds, after which the SLC is reset, even if the button is kept pressed. Naturally, if the button is released before this, the override function will terminate immediately.

8-1 LED's Description

The operator is able to recognise the operating status of the SLC by means of five LED located on the transceiver. The status of the LED indicates the following: (looking at the front of the transceiver from right to left)

Basic understanding of LED indicators

Disposition of indicator	Name of indicator	Colour	LED signal Pattern
	Power	Green	<ul style="list-style-type: none"> ● ON ○ OFF ◐ Blinking
	Lower	Yellow	
	Guard	Green	
	Break	Red	
	Upper	Yellow	

Normal Operation

LED signal Pattern	MEANING
● ○ ● ○ ○	OSSD ON
● ○ ○ ● ○	OSSD OFF, object in the field
● ○ ○ ● ●	Interlock, waiting for test button pressure
● ● ● ○ ●	Correctly aligned in aligning procedure
● ● ● ○ ○	Dust indication, probable lost of signal due to dust on the front cover
● ◐ ● ○ ○	A short circuit on OSSD is present

Faulty conditions

LED signal Pattern	MEANING
● ○ ○ ○ ○	Power supply is too low
● ◐ ○ ○ ◐	Micro controller fault
● ◐ ○ ◐ ◐	Fault on output system
● ◐ ◐ ○ ◐	Muting lamp connection fault or muting lamp burned
● ◐ ○ ○ ○	Optical defect

Section 9: Routine controls and maintenance



These checks are recommended and should be carried out on a regular basis by qualified personnel:

- (1) Check that the SLC remains blocked by inserting an object that intercepts the beams along the entire length of the protected area.
- (2) Check via the opening of the TEST/RESTART contact, that the safety outputs open (red LED lit and controller machinery stopped).
- (3) Check that it is not possible to access the danger areas of the machinery from any area that is not protected and that the minimum distance between the dangerous areas and the SLC is no less than that calculated as per formulas 4.1 and 4.2.)
- (4) Check that it is not possible for a person to get between the SLC and the dangerous parts of the machinery.
- (5) Check that there is no external damage to the SLC and/or to the external electrical connections.



Repeat checks 1 and 2 daily.



Repeat checks 1 to 5 every 6 month maximum.

The interval between the above actions can be shorter depends on the individual application and the environmental conditions where the SLC is used.

Section 10: Final checks after installation

- Check that the area protected by the SLC is free of obstacles.
- Check that the safety outputs open correctly by interrupting the protection beams (BREAK LED lit, machinery under control stops).

Section 11: General information and useful data

Everyone **MUST** be aware of issues regarding safety.

Safety devices are only useful if they are installed correctly according to the recommendations set down by regulations.

If you are not sure that you are able to install safety devices correctly, you should contact our service department or have them installed by a professional.

This appliance is covered by a total warranty for 12 months from the date of its delivery.

Faults that were clearly caused by damage due to incorrect use, accidental circumstances or catastrophic events are not covered by the guarantee.

In case of faults, please send the SLC to:

TECHNO-GR
via Torino, 13/15
10046 Poirino (TO) - ITALY
Tel. +39 011 9452041
FAX. +39 011 9452090
E-Mail info_technogr@eu.omron.com

A description of the fault found and the period of use must always accompany the appliance.

Section 12: Technical specifications

ITEM	VALUE
Rated operating distance	0,5m ... 6,0m K2C model 0,5m ... 5,0m K3C and K4C model
Emitted light source	Infrared LED (880 nm)
Ambient light immunity	According to IEC61496-2
beam pitch (center)	F3S-TGR-SBx-K2C-500 → 500 mm F3S-TGR-SBx-K3C-800 → 400 mm F3S-TGR-SBx-K4C-900 → 300 mm
number of beams	F3S-TGR-SBx-K2C-500 → 2 F3S-TGR-SBx-K3C-800 → 3 F3S-TGR-SBx-K4C-900 → 4
protective height	F3S-TGR-SBx-K2C-500 → 516 F3S-TGR-SBx-K3C-800 → 816 F3S-TGR-SBx-K4C-900 → 916
resolution	F3S-TGR-SBx-K2C-500 → 516 F3S-TGR-SBx-K3C-800 → 416 F3S-TGR-SBx-K4C-900 → 316
EAA	According to IEC 61496-2
Indicators	2 green LEDES 2 yellow LEDES 1 red LED
Dimensions (width x depth)	Profile: 35*45mm +2mm for connector part
Length	F3S-TGR-SBx-K2C-500: 595 mm F3S-TGR-SBx-K3C-800: 941 mm F3S-TGR-SBx-K4C-900: 1041 mm
Materials	Powder-coated aluminum,
Housing	Polycarbonate
Front panel	EPDM (synthesis rubber)
Sealing gasket	Metal: Galvanized brass
Connector parts	Plastic: PVC
Housing color	Yellow, RAL 1023
Connection	M12 connector, 8-pole
Operation temperature range	- 10 °C ... + 55 °C
Storage temperature range	- 25 °C ... + 70 °C
Relative humidity	15 % ... 95 % RH (no condensing)
Enclosure rating (EN 60529)	IP 65
Pollution degree	II
Installation category	II process control equipment
Altitude	Up to 2000m
External controls	Test/Restart Muting and override

ITEM	VALUE
Resistance to Vibration (to IEC 68-2-6) Shock (to IEC 68-2-27)	10 - 70 Hz 1.5mm amplitude, X, Y, Z directions 30G, 16ms, X, Y, Z direction
Rated operating voltage	+ 24 V DC, polarized
Operating voltage range	+19.2 ... 28.8 VDC
Current consumption	< 420mA (muting lamp included)
Power-on delay	< 800ms
Outputs	PNP
Output circuit protection	PNP short circuit protected
Output current	250 mA each OSSD
Max. Capacitive load	200nF (pure capacitive load)
Output voltage drop	< 2.0 V (excl. voltage drop due to cable extension)
Residual current	< 100 μ A
Circuit protection	Reverse polarity, Overload Short-circuit (pulsed)
Input circuit	Logical Zero level 0 - 8 V Logical One level 14 - 24 VDC
Input pulse duration	Min. 2 cycle time
Response time	\leq 16ms
Reset time (TOFF 'TON) (interlock)	\leq 300ms
Insulation resistance	800 M Ω @ 500 VDC
Dielectric voltage strength	350 VAC, 50/60 Hz (1 min)
Configuration	Manual reset / Automatic reset (default)
Operating modes	Muting / Override (by wiring setting)

Section 13: Dimensions

All dimensions are shown in millimetres

Mounting bracket

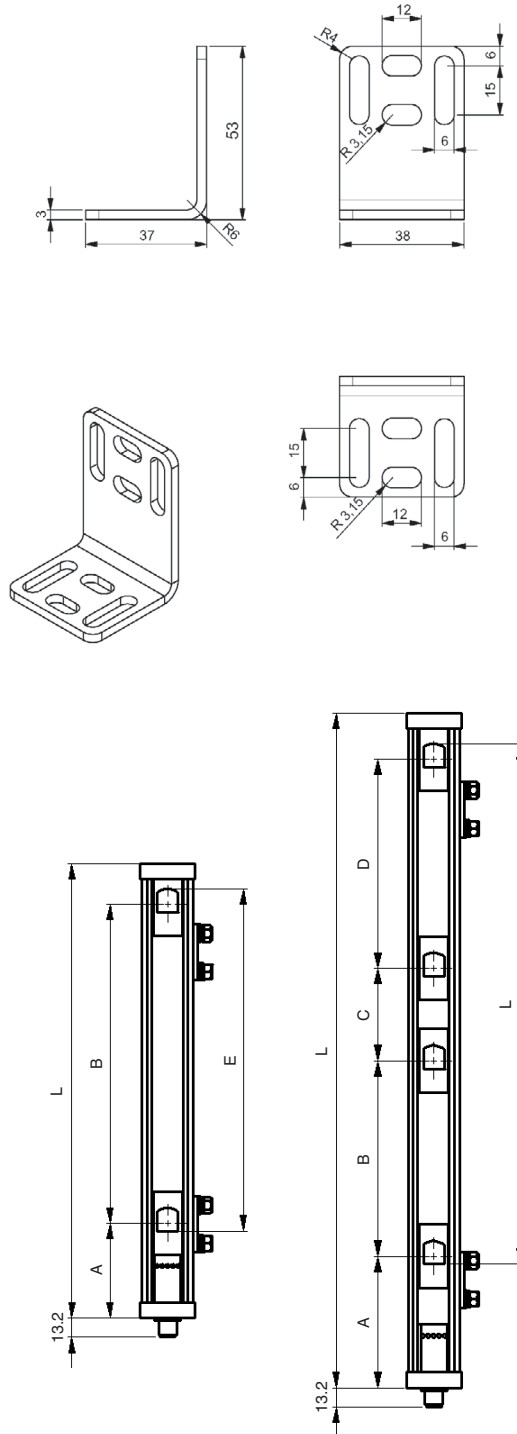

MODEL	A	B	C	D	E	L
F3S-TGR-SBx-K2C-500	66	500	---	---	516	595
F3S-TGR-SBx-K3C-800	110	400	60	340	816	941
F3S-TGR-SBx-K4C-900	110	300	300	300	916	1041

Section 14: Note
