

TABLE OF CONTENTS

SECTION 1

Important Precautions	5
1-1 Using the operating instructions	6
1-2 Use in accordance with the intended purpose	6
1-3 Use that is not in accordance with the intended purpose	6
1-4 Electromagnetic compatibility (EMC)	6
1-5 Warranty and liability	7
1-6 Key to symbols	7
1-7 Abbreviations	7

SECTION 2

Safety Notes	9
2-1 Safety notes	10

SECTION 3

Specification	11
3-1 Diffuse reflective sensor	12
3-2 Optical data link E3NT-AL232 (order separately)	17
3-3 Dimensions	18

SECTION 4

Function	23
4-1 Functions	24
4-2 Display and operator controls	26
4-3 User set parameters	27
4-4 Inputs/Outputs	33

SECTION 5

Transport	35
5-1 Packaging / Transportation damage	36
5-2 Storage	36
5-3 Scope of delivery	36

SECTION 6

Assembly	37
6-1 Safety notes	38
6-2 Sensor assembly	38

TABLE OF CONTENTS

SECTION 7

Electrical Connection	41
7-1 Safety notes	42
7-2 Establishing electrical connection	42
7-3 Connection diagrams	43
7-4 Connection in line with EMC requirements	45

SECTION 8

Setting into Operation	47
8-1 Safety notes	48
8-2 Switching on the operating voltage	48
8-3 Aligning the sensor	49
8-4 Setting the switching points	50

SECTION 9

Sensor Set-up	51
9-1 Setting the sensor using the push buttons	52
9-2 Setting the sensor with a PC	60

SECTION 10

Maintenance and Repair	61
10-1 Maintenance	62
10-2 Repair	62

SECTION 11

Accessories and Parts	63
11-1 Accessories and parts	64

SECTION 12

Appendix	65
12-1 Error messages	66
12-2 Factory default settings	67

SECTION 1

Important Precautions

1-1	Using the operating instructions	6
1-2	Use in accordance with the intended purpose	6
1-3	Use that is not in accordance with the intended purpose	6
1-4	Electromagnetic compatibility (EMC)	6
1-5	Warranty and liability	7
1-6	Key to symbols	7
1-7	Abbreviations	7

1-1 Using the operating instructions

These operating instructions refer exclusively to diffuse reflective sensors in the **E3NT** type series. They contain the most important notes for operating the sensor in line with safety requirements.

The operating instructions must always be close at hand and accessible at all times, and must be kept together with the higher-level machine installation.

The contents of these operating instructions must be read and understood, and all its points must be followed by everyone who is responsible for machine planning, assembly and operation. This particularly applies to the safety notes.

Observance of the safety notes will help to avoid accidents, malfunctions and faults.

1-2 Use in accordance with the intended purpose

Diffuse reflective sensors in the **E3NT** type series are always operated as part of a higher-level overall system, e.g. a machine installation.

They may only be used as optical sensors to check the presence of objects within a machine installation with a higher-level control system.

Any other use, or any use exceeding this scope, is not permitted.

Use in accordance with the intended purpose also includes observance of the operating instructions and keeping to the inspection and maintenance specifications in accordance with the system documentation.

1-3 Use that is not in accordance with the intended purpose

Diffuse reflective sensors in the **E3NT** type series must not be used as safety components within the scope of the EU machine guideline.

Its use in applications in which the safety of persons depends on functioning of the sensor is not permissible!

1-4 Electromagnetic compatibility (EMC)

Diffuse reflective sensors in the **E3NT** type series are built to conform to the following standards:

- EN 60947-5-2 Low-voltage switch gear - Part 5-2:
Control devices and switching elements: proximity switches
- EN 50081-2/-1 Basic interference emission standard
Industrial area/small establishments
- EN 61000-6-2 Basic interference immunity standard
Industrial area

1-5 Warranty and liability

Our Terms and **Conditions of Delivery and Payment** fundamentally apply. These are available to the owner at the latest as from conclusion of a contract. Warranty and liability claims for personal injury and property damage are ruled out if they are attributable to one or several of the following causes:

- Use of the sensor that is not in accordance with its intended purpose
- Improper assembly, commissioning and maintenance of the sensor
- Failure to observe the notes in the operating instructions in relation to transport, storage, assembly, commissioning and maintenance of the sensor
- Unauthorised structural changes to the sensor
- Repairs carried out improperly
- Disasters resulting from the influence of foreign bodies and acts of God.

1-6 Key to symbols

The following symbols are used in these operating instructions:



Important information



Risk of damage to the machine or material



Risk of injury to life and limb in general

1-7 Abbreviations

The following abbreviations are used in these operating instructions:

- **BGS** **BackGround Suppression**
- **FGS** **ForeGround Suppression**
- **IR** **InfraRed**
- **PC** **Personal Computer**

SECTION 2

Safety Notes

2-1	Safety notes	10
-----	--------------------	----

2-1 Safety notes



The diffuse reflective sensors belonging to the **E3NT** type series may only be used as described in these operating instructions. They may only be operated as part of a higher-level overall system, e.g. a machine installation.



During machine planning and the use of diffuse reflective sensors belonging to the **E3NT** type series, the safety and accident prevention regulations that are specific to use must be observed, e.g.:

- EN 292, Safety of machines, general design principles
- EN 60204, Electrical equipment of machines



Diffuse reflective sensors belonging to the **E3NT** type series must not be used as safety components within the scope of the EU Machine guidelines. Their use in applications in which the safety of persons depends on functioning of the sensor is not permissible!



The manufacturer and owner of the higher-level overall system, e.g. of a machine installation, is responsible for conformity with the national and international safety and accident prevention regulations that apply to the special application.



Assembly, electrical connection and maintenance may only be carried out by instructed, trained and authorised specialist personnel in accordance with applicable regulations after de-energising the power supply and switching off the machine.

The machine must be safeguarded against reactivation.



Conversions and changes as well as tampering with the interior of the sensor, the data link and the alignment tool are forbidden. The notes contained in these operating instructions, in particular the chapters entitled **Safety notes** and **Maintenance and repair**, must be integrated into the operating instructions of the higher-level overall system.

SECTION 3 Specification

3-1	Diffuse reflective sensor	12
3-1-1	General data	12
3-1-2	Optical data	12
3-1-3	Mechanical data	13
3-1-4	Electrical data	14
3-1-5	Standards and approvals	15
3-1-6	Parallel operating range	16
3-1-7	Black/White-error (6 % / 90 % remission, typical)	16
3-1-8	Hysteresis (typical)	16
3-2	Optical data link E3NT-AL232 (order separately)	17
3-3	Dimensions	18
3-3-1	Sensor E3NT-L17 with horizontal connector	18
3-3-2	Sensor E3NT-L37 with vertical connector	19
3-3-3	Universal mounting bracket E39-EL1 (order separately)	20
3-3-4	Adapter bracket E39-EL2 (order separately)	20
3-3-5	Optical data link E3NT-AL232 2m (order separately)	21

3-1 Diffuse reflective sensor

3-1-1 General data

Sensor type E3NT-L□□7	Diffuse reflective sensor with background respectively foreground suppression
Signal evaluation	Double triangulation method
Options	Window heating, analog output
User settings	By push button on the sensor or with a PC connected via the optical data link (order separately)
Operating modes	Background suppression, foreground suppression, background and foreground suppression (2-point window evaluation)
Optical data link (order separately)	Set-up via a PC, real-time analog value output, firmware update

3-1-2 Optical data

Emitted light	Infrared, 850 - 880 nm
Rated sensing distance	2 m
Setting distance, Sr	teachable/manual set-up 0.2 ... 2.0 m (90 % remission) 0.2 ... 1.7 m (6% remission)
Standard measured object	Kodak grey card 90%, 200 x 200 mm
Blind zone	< 0.1 m
Black/white error (6%/90%)	< 15 % (of setting distance Sr)
Hysteresis	< 5 % of setting distance Sr (remission 90 %) or max. 4 cm < 10 % of setting distance Sr (remission 6 %) or max. 6 cm (higher value valid)
Repetition accuracy	< 5 % (of setting distance Sr) or 4 cm (higher value valid)
Light spot diameter	< 40 mm in the case of Sr = 2 m
Minimum object size	> 40 mm
Ambient light immunity to EN 60947-5-2 Halogen lamps (100-120 Hz) Fluorescent lamps (30 kHz) Energy saving lamps	> 10,000 lux > 5,000 lux > 2,000 lux (max. illuminance of an energy saving lamp)

3-1-3 Mechanical data

Dimensions (length x width x depth)	85 x 27 x 65 mm
Materials	
Housing	Powder-coated aluminium, sea-water resistant, 231 GD AlSi12 (Cu) (standard version)
Front pane	Aluminium with foodstuff-approved coating (option)
Keyboard	Glass
Seals	HTV silicone RTV silicone
Housing colour	Grey, RAL 7030
Assembly	Screw fastening by way of four M5 threads and two M5 through holes or with universal mounting bracket (order sepa- rately)
Connection	M12 connector, 5-pole (piercing)
Ambient temperature range	- 40 °C ... + 55 °C (with window heating) - 25 °C ... + 55 °C - 10 °C ... + 55 °C (analog output)
Storage temperature range	- 40 °C ... + 60 °C
Permissible relative humidity	35 % ... 95 %, no condensation
Front pane heating	optional
Degree of protection to EN 60529/IEC 529	IP 67
Protection class	II (50 V DC)
Resistance to	
Vibration (to IEC 68-2-6)	± 1.5 mm, 1 h , 10 - 70 Hz
Shock (to IEC 68-2-27)	300 m/s ²

3-1-4 Electrical data

Utilisation category to EN 60947-5-2	DC 12
Rated operating voltage	+ 24 V DC, polarised
Operating voltage range	+ 10 ... + 30 V DC
Current consumption	< 90 mA with the display off < 110 mA with the display on
Power-on delay	< 300 ms
Inputs/outputs	Pin 2 = input (In 2) or output (Out 2) depending on set-up Pin 4 = output (Out 1) Pin 5 = Input (In 1) or analog output depending on model
Outputs	User set functions (e.g. switching output, alarm output, ...)
Output circuit	User set PNP (open collector), NPN (open collector) or complementary (push-pull)
Output current	max. 100 mA
Voltage drop	< 2.0 V
Residual current	< 100 μ A
Circuit protection	Reversed power supply, overload and short-circuit (pulsed), mutual interferences
Inputs	User set functions (e.g. teach-in, trigger, test, ...)
Input circuit	Voltage input +10 V ... U_{Supply}
Pulse duration	min. 1 ms
Analog output	Current output 0 ... 21 mA - 3 mA correspond to distance < 0.2 m - 4 ... 20 mA correspond to distance 0.2 m ... 2.0 m - 21 mA correspond to distance > 2.0 m (or no object)
Switch-on/off time (T_{ON} / T_{OFF})	\leq 2.5 ms
Insulation resistance	20 M Ω at 500 V DC
Insulation voltage strength	1 kV AC, 50/60 Hz (1 min)
Impulse strength (insulation)	6 kV

3-1-5 Standards and approvals

Interference withstand	
General	EN 60947-5-2 Proximity switches EN 61000-6-2 Generic interference immunity standard, industrial area
Static discharge (ESD)	EN 61000-4-2 Contact ± 4 kV / air ± 8 kV Function criterion A*
High-frequency electromagnetic fields (HF)	EN 61000-4-3 80 ... 1000 MHz, 10 V/m, 80 % Function criterion A*
Fast transient interference quantities (burst)	EN 61000-4-4 ± 2 kV, t/th = 5/50 (ns) Function criterion A*
Impulse voltages (surge)	EN 61000-4-5 ± 1 kV, t/th = 1.2/50 (ns) Function criterion B*
Conducted disturbances	EN 61000-4-6 3 V, 0.15 ... 80 MHz, 80 % Function criterion A*
Interference emission	
General	EN 60947-5-2 Proximity switches EN 50081-2 Generic interference emission standard, industrial area EN 50081-1 Generic interference emission standard, small establishments
Radio interference field strength	EN 55011, 30 ... 1000 MHz
Radiated radio interference power	EN 55011, 1 GHz ... 18 GHz
Permits	UL (pending), CSA (pending)

* **Function criterion A**
Normal functioning also ensured during a disturbance.

* **Function criterion B**
Normal functioning ensured after a disturbance.

3-1-6 Parallel operating range

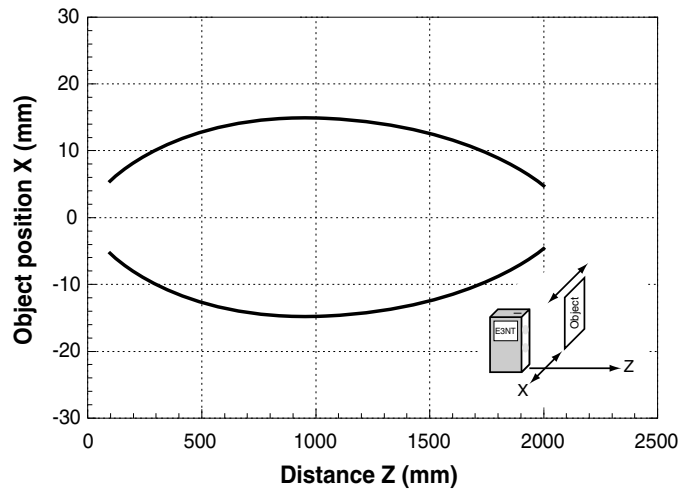

3-1-7 Black/White-error (6 % / 90 % remission, typical)

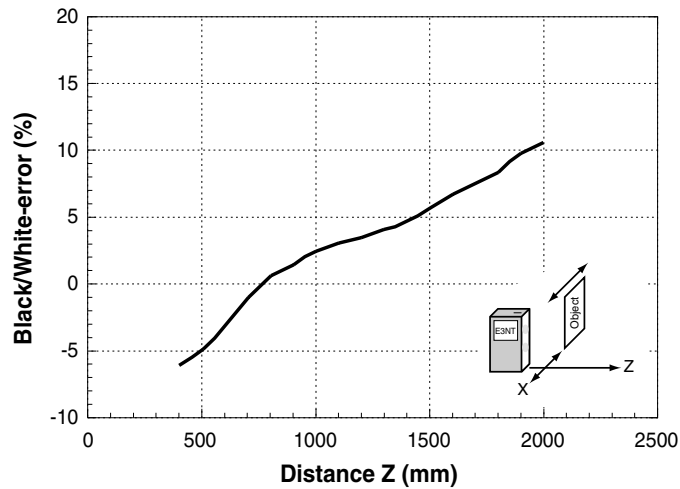

3-1-8 Hysteresis (typical)

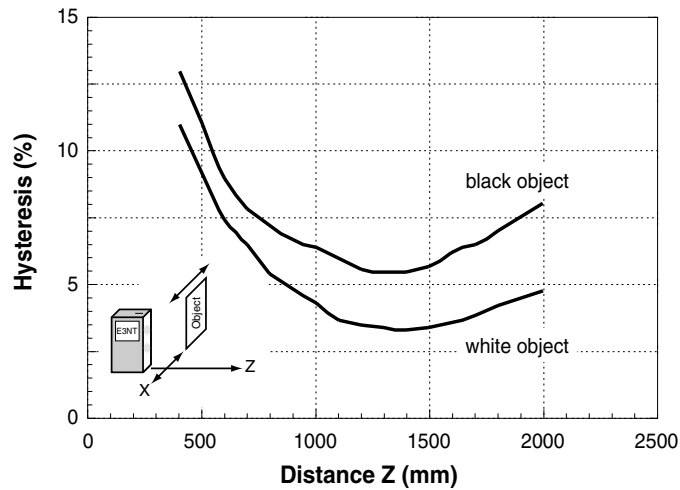

3-2 Optical data link E3NT-AL232 (order separately)

Dimensions (length x width x depth)	29.5 x 72.9 x 26.4 mm
Housing material	ABS and PMMA (IR transparent)
Housing colour	Black, RAL 9005
Assembly	Snap mounting on sensor
Connection	2 m connecting cable with 9-pole sub-D connector
Ambient temperature range	- 10 °C ... + 50 °C
Storage temperature range	- 40 °C ... + 60 °C
Permissible relative humidity	35 % ... 85 %, no condensation
Degree of protection to EN 60529 / IEC 529	IP 54
Emitted light	IR communication element 880 nm
Rated operating voltage	Via RS232 interface from PC
Current consumption	6 mA

3-3 Dimensions

3-3-1 Sensor E3NT-L17 with horizontal connector

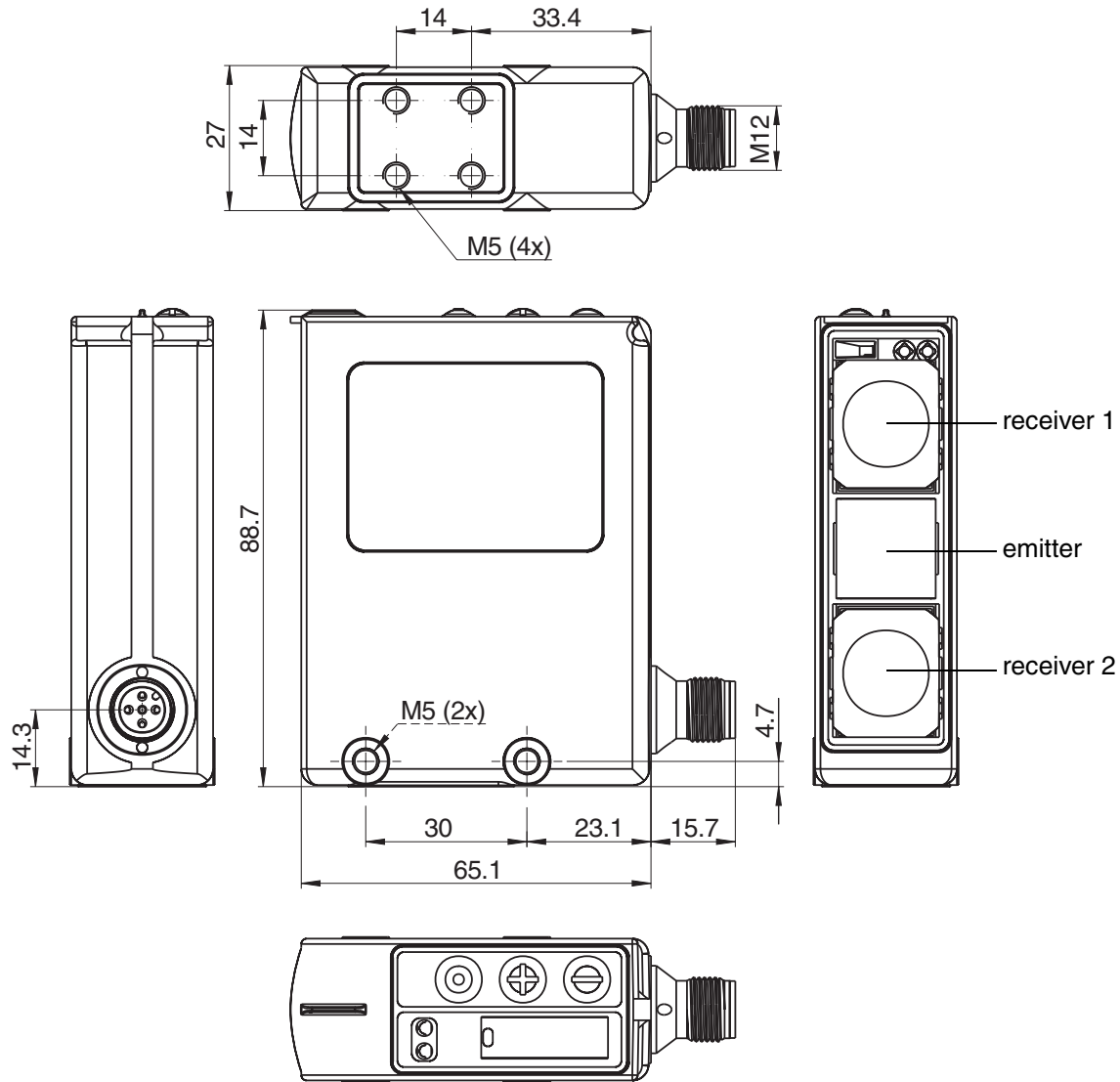

3-3-2 Sensor E3NT-L37 with vertical connector

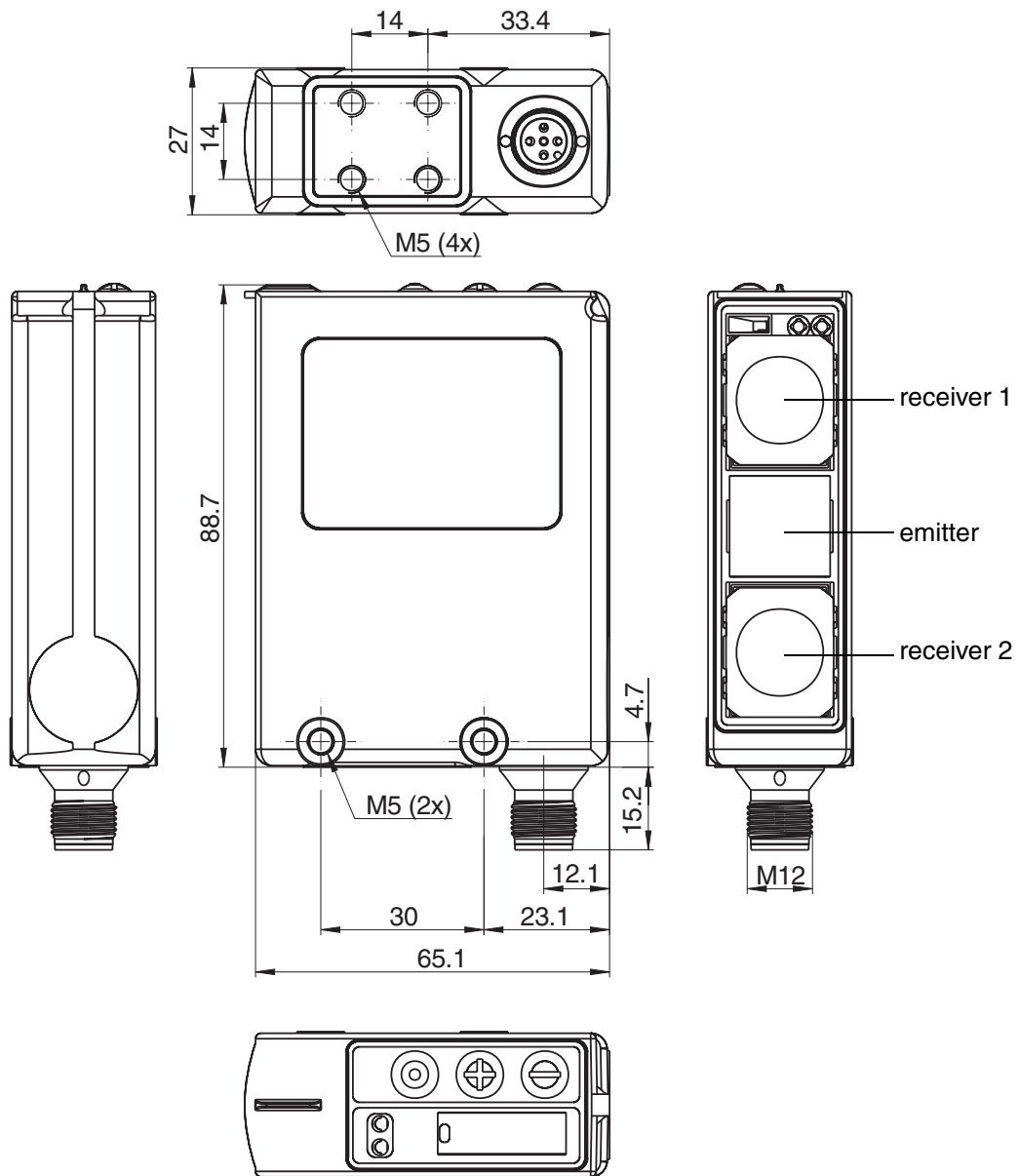

3-3-3 Universal mounting bracket E39-EL1 (order separately)

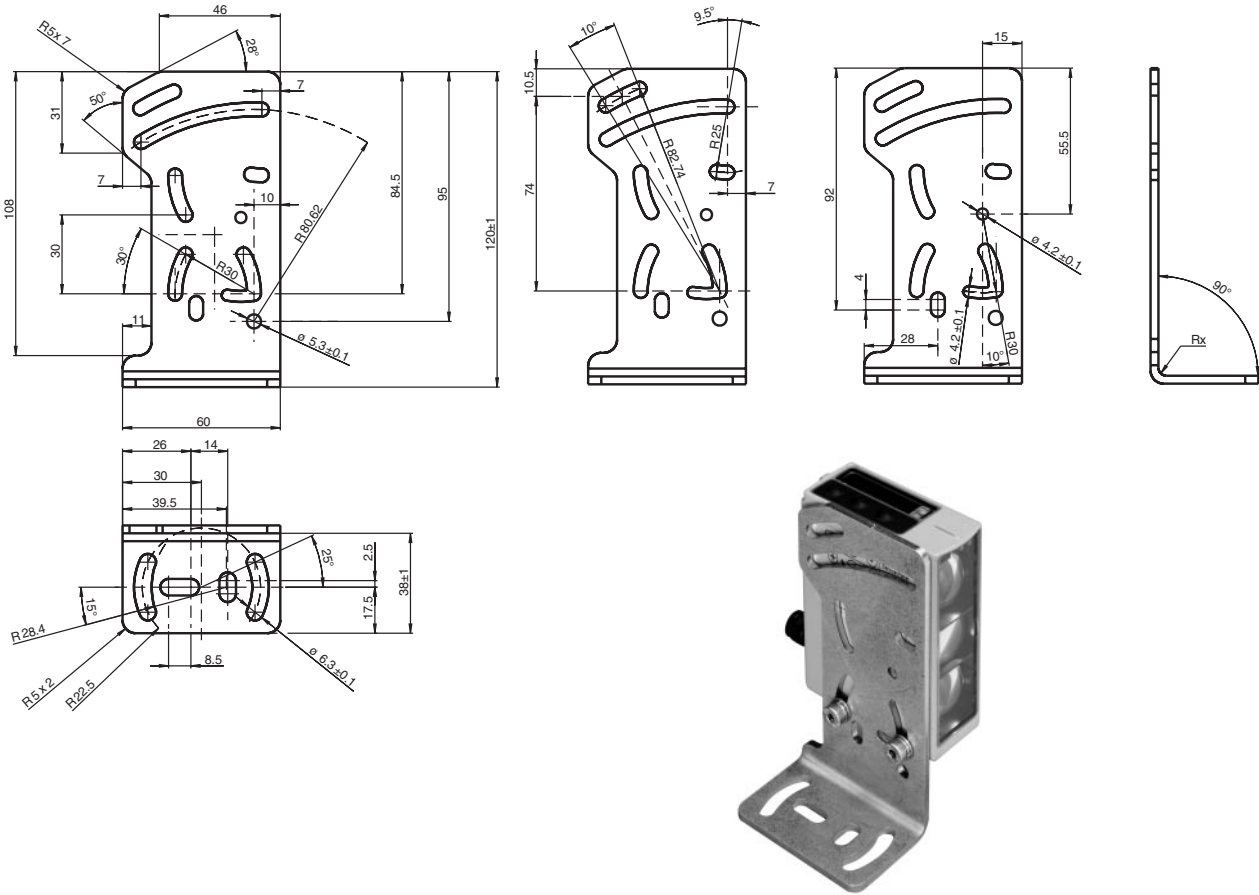

3-3-4 Adapter bracket E39-EL2 (order separately)

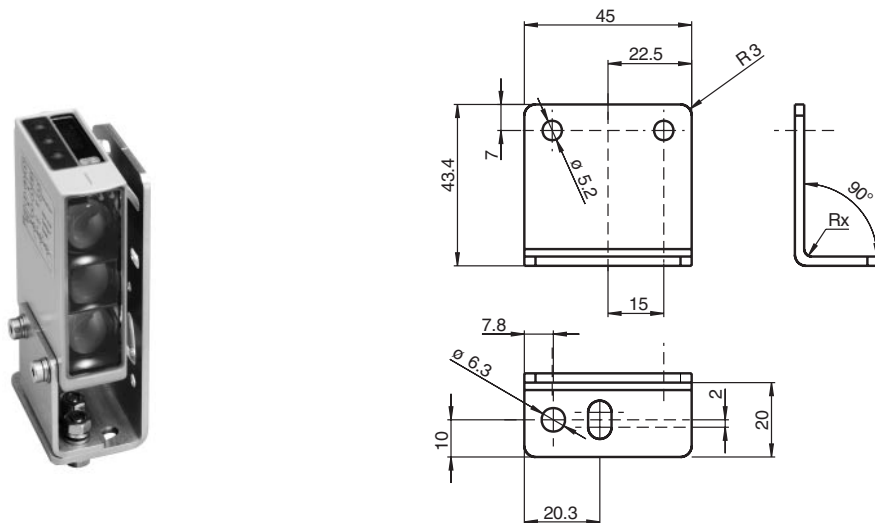

3-3-5 Optical data link E3NT-AL232 2m (order separately)

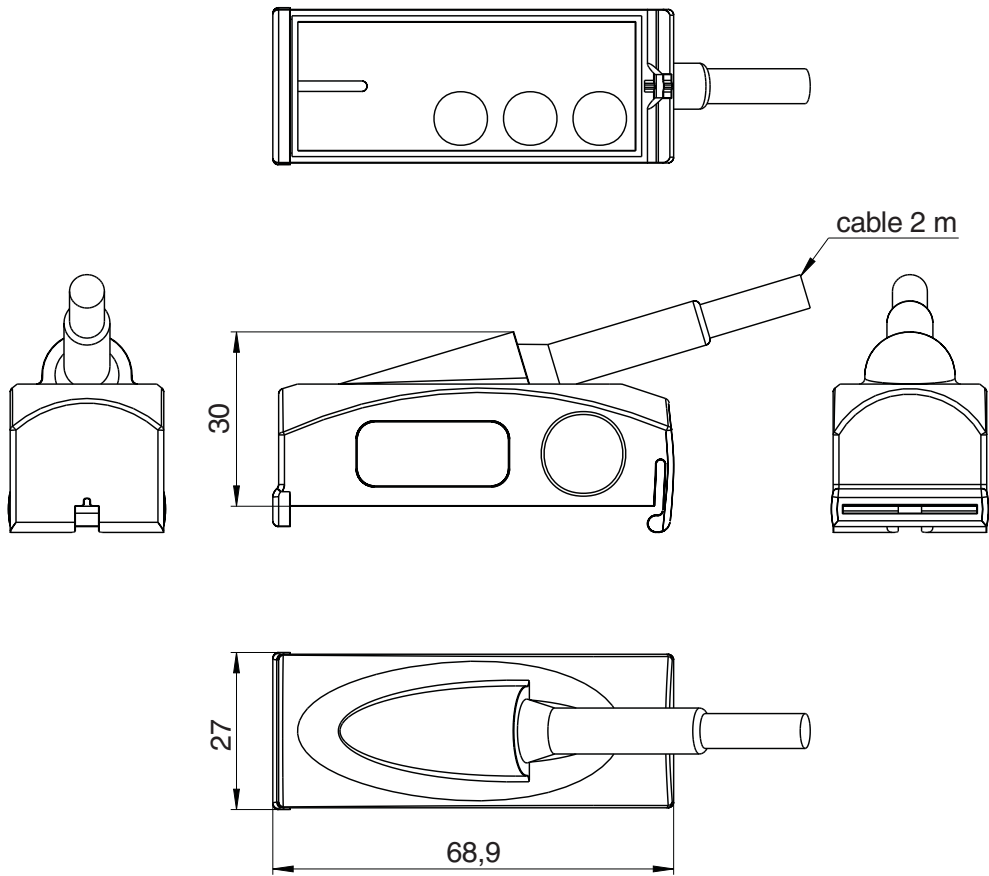

SECTION 4 Function

4-1	Functions	24
4-2	Display and operator controls	26
4-2-1	LED display	26
4-2-2	LEDs	26
4-2-3	Push buttons on the sensor	27
4-2-4	Set-up via a PC	27
4-3	User set parameters	27
4-3-1	Mode	28
4-3-2	Output function	29
4-3-3	Switching points	29
4-3-4	Output switching	29
4-3-5	Function of connector pin 2	30
4-3-6	Switch-on delay	30
4-3-7	Switch-off response	30
4-3-8	Timing diagrams	31
4-3-9	Type of display	32
4-3-10	Keyboard lock	32
4-3-11	ECO energy saving mode	32
4-3-12	Direction of the display	32
4-3-13	Reset	32
4-4	Inputs/Outputs	33
4-4-1	Inputs	33
4-4-2	Outputs	34

4-1 Functions

Diffuse reflective sensors in the **E3NT** type series can be operated with background and foreground suppression. Genuine **window** evaluation can also be set. The distance is evaluated in accordance with the double triangulation principle. In this case, the distance from the measured object is determined not only via the intensity of the reflected emitted light, but also via the angle between the emitter, the measured object and the receiver.

- i

Contrary to sensors with single triangulation, **E3NT** with double triangulation, allows measured object's direction of motion to be in all three directions. Thus, the rotatory position of the sensor about its optical axis can be chosen freely (see *Figure 1 Position of the sensor*).

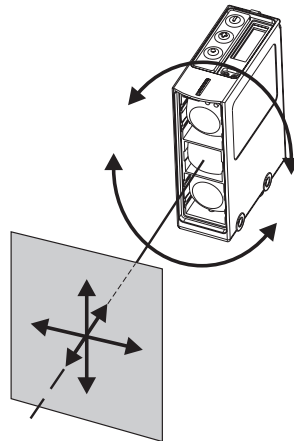

Figure 1 Position of the sensor

- i

If the light spot is not completely on the same plane target object (minimum object size) the distance is not determined and malfunction can occur (see *Figure 2 Not determined distance*). If necessary a trigger signal or timer function has to be applied.

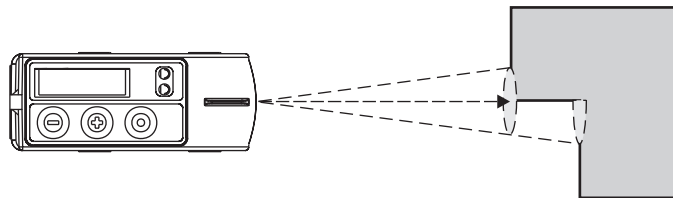

Figure 2 Not determined distance

Measured objects are detected only within the user set and strictly limited sensing zone. Objects outside the sensing zone (depending on the settings, in the background, in the foreground or outside of a window that is defined by two user set distance points) are ignored.

Due to the infrared emitted light and the very low minimum reflection factor of 6 %, objects can be detected largely independently of their colour and their surface finish. The sensor can be user set by push button on the unit or with a PC and the **SensorSupportSoftware S³** (order separately) via an optical data interface **E3NT-AL232** (order separately). The optical data interface operates with an IR communication element. Through the optical data interface, the analog distance data can also be transferred continuously to a PC/laptop and stored there.

4-2 Display and operator controls

Operating states are displayed by a 4-digit 7-segment LED display and two LEDs.

The sensor can be operated/set either by push buttons on the sensor or with a PC and setting software (order separately) via an optical data interface (order separately).

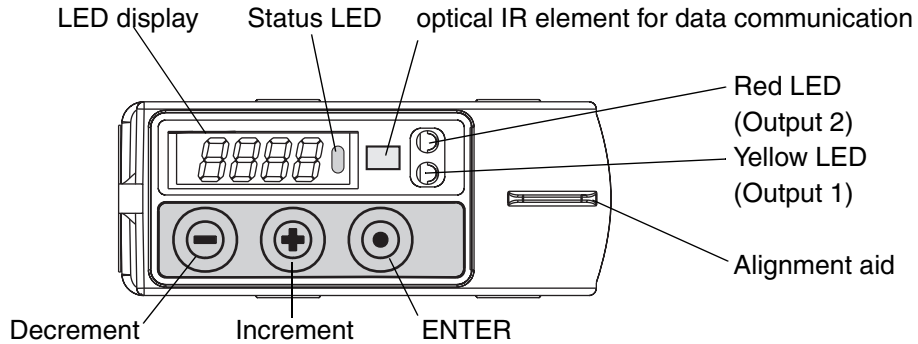

Figure 3 Operator controls and displays

4-2-1 LED display

The distance from the measured object and the names of the menu levels during set-up of the sensor are displayed by the 4-digit 7-segment LED display. The display appears as red digits or letters.

If the sensor is set to a bar chart display, the distance from the measured object is displayed as a green LED bar chart.

4-2-2 LEDs

The switching status and the stability of the two outputs are signalled as follows by two LEDs, visible from the top and the front of the sensor:

- Yellow LED (Output 1)
 - ON: Object stably detected
 - Blinking: Object not stably detected
 - OFF: No object within range
- Red LED (Output 2)
 - ON: Object stably detected
 - Blinking: Object not stably detected
 - OFF: No object within range

The status LED is only visible from the top of the sensor:

- Status LED
 - ON: Set-up menu selected
 - Blinking: Menu level with change of setting distance
 - OFF: RUN (normal) mode

4-2-3 Push buttons on the sensor

On the sensor, there are three push buttons for the setting of the sensor (see *Figure 3 Operator controls and displays*):

- Minus key ⊖
- Plus key ⊕
- Enter key ●

With these three push buttons, the operator moves through the sensor's menu and sets the parameters in accordance with the application. Therefore, the most frequently used parameters can be set directly on the sensor.

4-2-4 Set-up via a PC

All parameters of the sensor can be set with a PC and the **OMRON Sensor-SupportSoftware S³**. The connection between the sensor and the PC is established via an optical data interface. The data interface is connected to a free COM port of a PC/laptop.

Refer to the separate operating instructions ABBO 0018 for further information on setting with a PC and the **SensorSupportSoftware S³**.

4-3 User set parameters

The following parameters can be user set either by push buttons on the sensor or with a PC and the set-up software (order separately) via the optical data interface (order separately):

- Mode
- Output function
- Teach/set switching points
- Output switching
- Function on connector pins 2 and 5
- Switch-on and off delay
- Type of switch-off time function
- Type of display on the sensor
- Keyboard lock
- Energy saving mode
- Display direction
- Reset to factory defaults

The following functions can only be set with a PC and the set-up software (order separately) via the optical data interface (order separately):

- Complete sensor locking

4-3-1 Mode

The diffuse reflective sensor can be operated in the following modes:

- Background suppression **BGS** (factory default)
 Measured objects are detected as from the blind zone up to the user set or teached switching point S_A . Objects in the background, behind the user set switching point, are ignored.

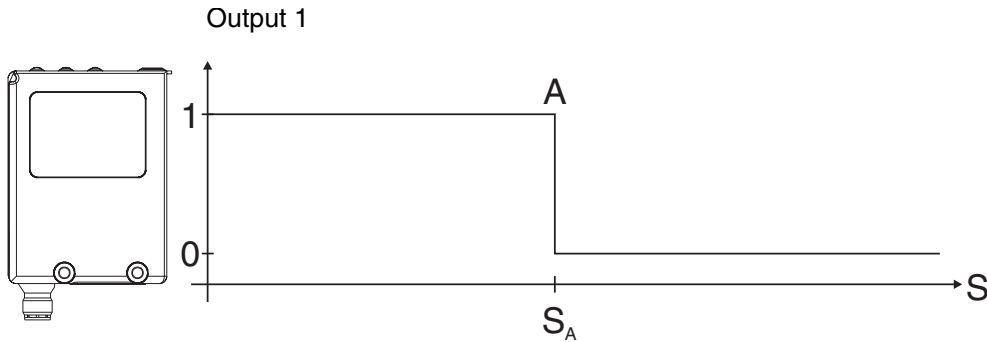

Figure 4 Background suppression

ⓘ Accordingly for output 2 the switching point C (S_C) is set.

- Foreground suppression **FGS**
 Measured objects are detected as from the user set switching point S_A up to the maximum sensing distance. Objects in the foreground, between the sensor's blind zone and the user set switching point, are ignored.

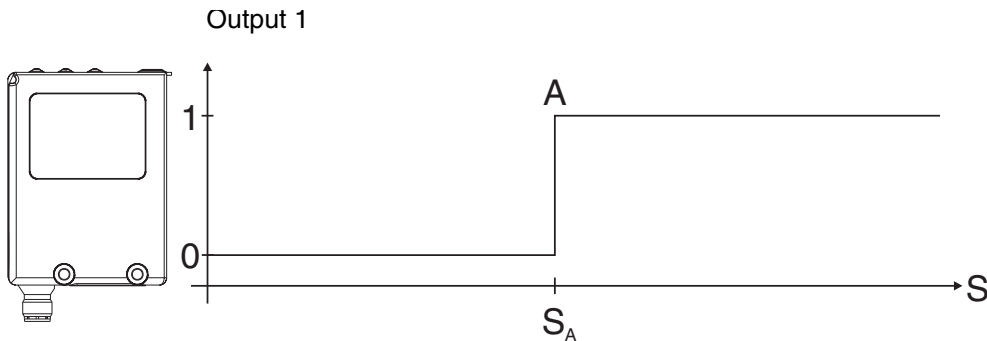

Figure 5 Foreground suppression

ⓘ Accordingly for output 2 the switching point C (S_C) is set.

- **Window** evaluation

Measured objects are detected only in the measurement window between the two user set switching points (switching zone). Objects outside of this measurement window in the foreground and in the background are ignored.

Window evaluation involves logical AND combination of the **FGS** and **BGS** modes.

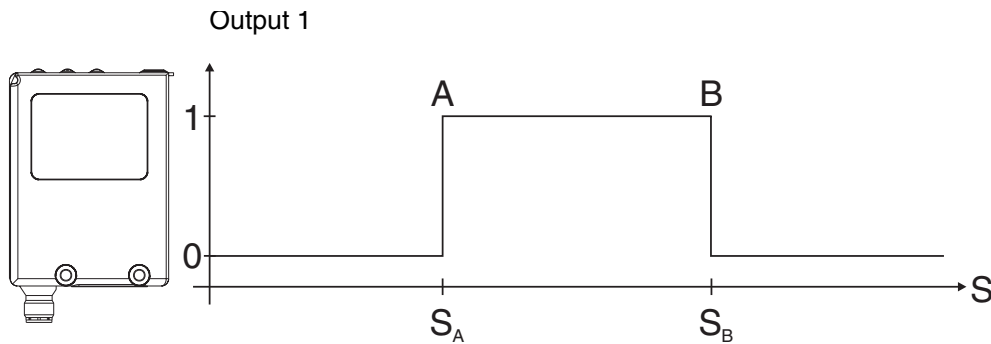

Figure 6 Window evaluation

Accordingly for output 2 the switching points C and D are set.

4-3-2 Output function

The output function can be set separately for both outputs:

- Light on (factory default)
The output is active when a measured object is detected.
- Dark on
The output is active when no measured object is detected.

4-3-3 Switching points

The switching points can be set on a positioned measured object or can be user set by input of switching points.

In the **window** evaluation mode, two switching points must be defined for each output.

In the **FGS** or **BGS** mode, only one switching point needs to be defined for each output.

4-3-4 Output switching

Output switching can be user set jointly for both outputs:

- PNP, plus-switching, open collector (factory default)
- NPN, minus-switching, open collector
- Push-pull, complementary, plus/minus-switching

See SECTION 7-3 Connection diagrams.

4-3-5 Function of connector pin 2

Pin 2 of the connector can be user set as Output 2 (OUT 2), as an alarm output, as a teaching input for switching points A and B, as a test input or as a trigger input.

4-3-6 Switch-on delay

This defines the switch-on response (light-on mode). The time is adjustable between 0 ms and 9999 ms.

- Switch-on delay

The switch-on delay starts as from the time when the measured object enters the sensing zone. The output does not become active until the switch-on delay has elapsed.

4-3-7 Switch-off response

This defines the switch-off response (light-on mode). The time is adjustable between 0 ms and 9999 ms.

- Switch-off delay

The switch-off delay starts as from the time when the measured object leaves the sensing zone. The output does not become inactive until the switch-off delay has elapsed.

- Minimum pulse width

After detection of a measured object, the output remains active for at least the user set switch-off delay. If the measured object dwells in the sensing zone for longer than the set switch-off delay, the output becomes inactive immediately after the object leaves the sensing zone.

- Constant pulse width

After detection of a measured object, the output only remains active during the user set switch-off delay and becomes inactive after this time has elapsed, regardless of the measured object's dwell time, even if the measured object stays in the sensing zone for longer than the user set switch-off delay.

4-3-8 Timing diagrams

Timer functions off

object detected not detected
ON OFF

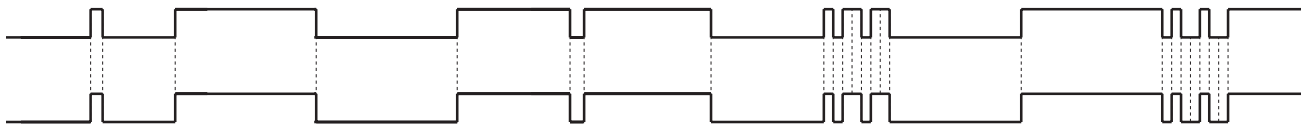

Mode on-1 (on-/off-delay)

object detected not detected
only on-delay ON OFF
only off-delay ON OFF

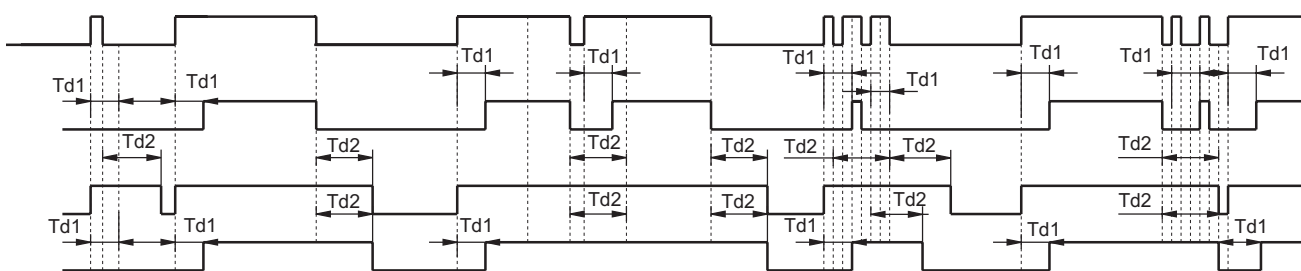

Mode on-2 (minimum pulse width)

object detected not detected
ON OFF

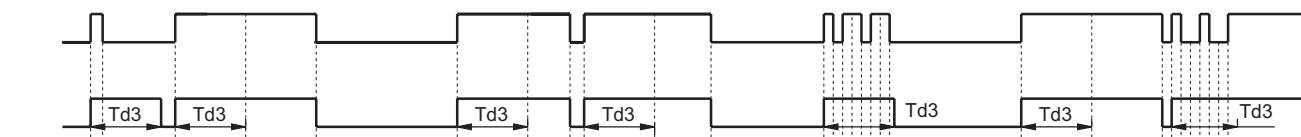

Mode on-3 (constant pulse width)

ON OFF



note: on-delay: Td1 off-delay: Td2 min/const.: Td3

4-3-9 Type of display

The measured distance can be displayed on the sensor's display in two different ways:

- Absolute
The absolute distance between the sensor and the measured object is displayed with red digits in m.
- Bar
The distance between the sensor and the measured object is displayed as a green bar chart.

4-3-10 Keyboard lock

With the keyboard lock function, the push buttons on the sensor can be locked to prevent inadvertent modification of the settings.

The lock can be activated and deactivated on the sensor.

When the keyboard lock is active, changes can only be made if the Minus ⊖ and Plus ⊕ keys have been pressed simultaneously for 4 seconds. This temporarily suppresses keyboard locking. If no key is pressed for about 5 minutes, the keyboard lock is automatically activated again.

4-3-11 ECO energy saving mode

In the ECO mode, the display switches off automatically approximately 5 minutes after the push buttons have been pressed for the last time.

The display is activated again the next time the push buttons are pressed.

Deactivation of the sensor display reduces the sensor's current consumption by approximately 20 mA.

4-3-12 Direction of the display

To improve readability, the display can be rotated by 180° when fitted. It is then "upside down".

4-3-13 Reset

Reset returns the sensor to the factory default settings.

4-4 Inputs/Outputs

In total, the sensor can be operated with a maximum of three inputs/outputs. The functions of the inputs/outputs are user determined.

Connector pin 4 is always defined as Output 1 (OUT 1).

Connector pin 2 can be set as Output 2 (OUT 2), as alarm output (ALARM), as teaching input (TEACH) for switching points A or B, as test input (TEST) or as trigger input (TRIG).

Connector pin 5 can be set as trigger input (TRIG) as teaching input (TEACH) for switching points A to D or as test input (TEST)

4-4-1 Inputs

4-4-1-1 Teaching input TEACH

Connector pins 2 and 5 can be set as teaching inputs for the switching points A to D.

If a signal in the operating voltage range is applied to this input, the sensor is taught the switching point A, B, C or D depending on the user set preferences.

4-4-1-2 Test input TEST

Connector pins 2 and 5 can be set as test inputs.

The emitter is deactivated if a signal in the operating voltage range is applied to this input.

If a measured object is located in the sensor's detection zone, regardless of the user set switching points the receiver detects the absence of the emitted light reflected by the measured object.

Depending on the object position the output status is altered.

4-4-1-3 Trigger input TRIG

Connector pin 2 and pin 5 can be set as a trigger input.

If a signal in the operating voltage range is applied to this input, the sensor is prompted to output a measurement result (object distance).



The sensor/switching speed can be increased by the trigger function.

4-4-2 Outputs

4-4-2-1 Switching outputs OUT 1 and OUT 2

When a measured object is detected, the switching outputs OUT 1 (Connector pin 4, fixed) and OUT 2 (Connector pin 2) switch in accordance with the sensor's settings.

4-4-2-2 Alarm output ALARM

Connector pin 2 can be set as the alarm output.

The alarm output is switched on if the intensity of reflected light is too low or no measured object is detected.

SECTION 5

Transport

5-1	Packaging / Transportation damage	36
5-2	Storage	36
5-3	Scope of delivery.....	36

5-1 Packaging / Transportation damage

- Do not damage the sensor by other objects during transportation
- Only ever use the sensor's original packaging sealed properly for transportation
- Keep the sensor's original packaging for later use
- Report transportation damage immediately in writing to the haulage contractor and **OMRON**

5-2 Storage

- Only ever store the sensor in original packaging that has been sealed properly
- Protect against dust and moisture

5-3 Scope of delivery

The sensor's scope of delivery consists of:

- Diffuse reflective Sensor **E3NT-L**
- Short-form instructions
- Operating instructions on CD-ROM

SECTION 6

Assembly

6-1	Safety notes	38
6-2	Sensor assembly	38
6-2-1	Sensor's assembly direction	39
6-2-2	Assembly via assembly holes	40
6-2-3	Assembly by universal mounting bracket E39-EL1	40
6-2-4	Assembly with adapter bracket E39-EL2 and bracket E39-EL1 . . .	40

6-1 Safety notes

 Assembly, electrical connection and maintenance must only be carried out by instructed, trained and authorised specialist personnel in accordance with applicable regulations, after de-energising the power supply and with the machine switched off.

The machine must be safeguarded against reactivation.

 Conversions and changes and tampering in the interior of the sensor, the data interface and the alignment tool are forbidden.

 During assembly, do not knock the sensor or drop it.

 The ambient conditions at the assembly location must conform to the technical data (see SECTION 3 Specification).

6-2 Sensor assembly

 Contrary to sensors with single triangulation, **E3NT** with double triangulation, allows the measured object's direction of motion to be in all three directions. Thus, the rotatory position of the sensor about its optical axis can be chosen freely (see Figure 1 Position of the sensor).

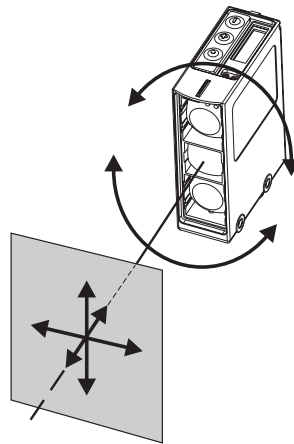



Figure 1 Position of the sensor

 If the light spot is not completely on the same plane as the target object (minimum object size) the distance is not determined and malfunction can occur (see Figure 2 Not determined distance). If necessary a trigger signal or timer function has to be applied.

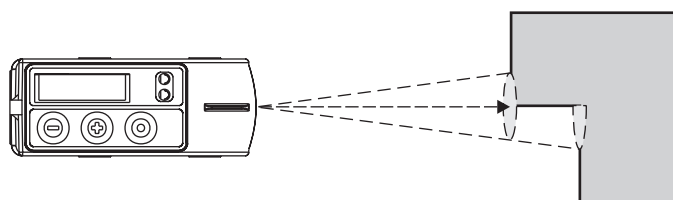

Figure 2 Not determined distance

The sensor must be fitted so that:

- It is correctly aligned before it is adjusted
- It is protected as far as possible against vibration and shock
- It is protected as far as possible against extraneous incident light
- It is protected as far as possible against damage and soiling
- Electrical connection is possible
- It is as accessible as far as possible for maintenance work
- Operation of the push buttons is possible
- The display is visible.

6-2-1 Sensor's assembly direction

As far as possible, the sensor's optical surface should be aligned parallel to the surface of the measured object.

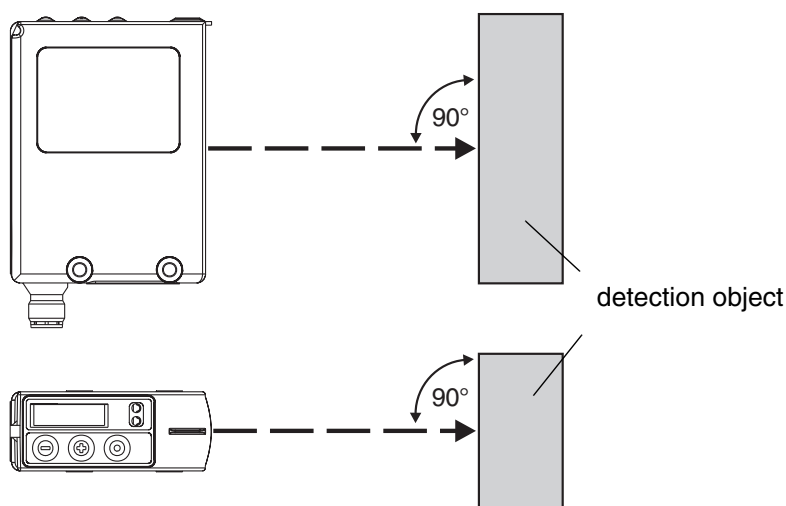

Figure 3 Parallel alignment

- i** If the measured object has a glossy, reflecting surface, the sensor's optical system should be tilted by $5^\circ \dots 10^\circ$ in relation to the surface of the measured object.

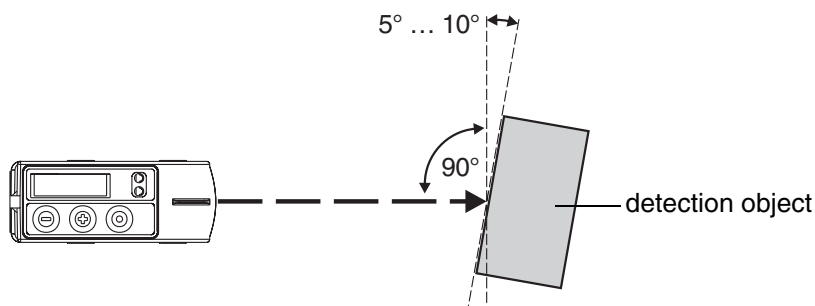

Figure 4 Alignment for glossy surfaces

- || If there is a reflecting surface in parallel with the sensor's optical axis, this might lead to unstable switching states.
Therefore, reflecting objects within the sensor's optical axis should be avoided.
If this should not be possible, the reflecting surface should not be parallel to the sensor's optical axis, but should be rotated by at least 10°.
- || Mirror-like objects can cause malfunction inside and outside the sensing range. Avoid mirror-like objects in or close to the optical axis.

6-2-2 Assembly via assembly holes

1. Professionally produce securing holes/threaded holes corresponding to the six possible assembly holes of the sensor (*see Section 3-3 Dimensions*).
2. Professionally attach the sensor with suitable securing material.
3. Roughly align the sensor to the possible position of the measured object.
4. Tighten the securing screws.



6-2-3 Assembly by universal mounting bracket E39-EL1

1. Drill and tap the necessary securing holes / threaded holes according to the required pattern of the universal mounting bracket (*see Section 3-3 Dimensions*).
2. Using the included securing material, professionally fit the sensor on the mounting bracket.
3. With suitable securing material, professionally fit the mounting bracket on the body of the machine.
4. Roughly align the sensor to the possible position of the measured object.
5. Tighten the securing screws.



6-2-4 Assembly with adapter bracket E39-EL2 and bracket E39-EL1

Applying the adapter bracket E39-EL2 the universal mounting bracket E39-EL1 can be used as an adapter plate to mount the E3NT to existing holes.

1. Mount the bracket E39-EL1 to the existing assembly holes on the machine, if necessary produce additional ones.
2. Using the included securing material of the E39-EL1 professionally fit the sensor to the adapter bracket E39-EL2.
3. Using the included securing material professionally fit the adapter bracket to the universal mounting bracket E39-EL1.

SECTION 7

Electrical Connection

7-1	Safety notes	42
7-2	Establishing electrical connection.	42
7-3	Connection diagrams.	43
7-3-1	Output circuits	43
7-3-2	Input circuits	44
7-3-3	Connector pin assignments	45
7-4	Connection in line with EMC requirements	45

7-1 Safety notes



Assembly, electrical connection and maintenance must only be carried out by instructed, trained and authorised specialist personnel in accordance with applicable regulations, after de-energising the power supply and with the machine switched off.

The machine must be safeguarded against reactivation.



Conversions and changes and tampering in the interior of the sensor, the data interface and the alignment tool are forbidden.



- A technical data of the supply voltage and of the input/output wires must conform to the technical data of the sensor (see sensor rating plate and SECTION 3 Specification).



- Do not lay the sensor's connecting leads in the direct proximity of cables carrying higher voltages or together with cables that switch inductive or capacitive loads.



- A power supply unit that conforms to the necessary EMC requirements must be used.



- The operating voltage must be within the applicable operating voltage range. Unstabilised full or half-wave rectifiers must not be used for the power supply.



- The electrical connection must conform to EMC requirements.



- The equipotential bonding system for the machine must be produced in conformity with EN 60204-1, Section 8 "Equipotential bonding".



- Check the operability of all equipotential bonding conductors in conformity with Section 20 of EN 60204-1 before releasing the machine for operation.

7-2 Establishing electrical connection

1. Establish electrical connection in conformity with the pin assignments described in SECTION 7-3 Connection diagrams.
2. Professionally establish the equipotential bonding system, the protective earthing, the shielding and the sensor wiring in line with EMC requirements (*see Section 7-4 Connection in line with EMC requirements*).

7-3 Connection diagrams

7-3-1 Output circuits

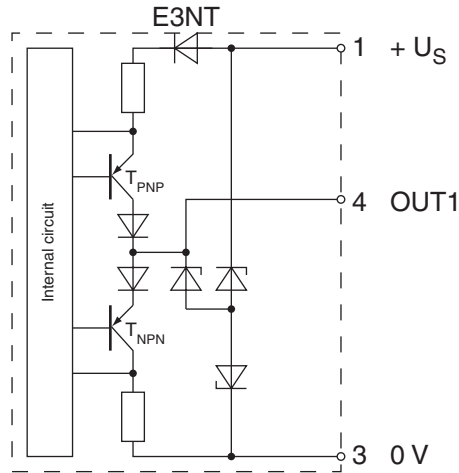

Figure 1 Push-pull output circuit (OUT1 at pin 4 / OUT2 at pin 2)

The sensor is factory set to a PNP output.

The output circuit is resistant to short-circuits and reversed power supply.

When use is made of the PNP or NPN output circuit, the output circuit that is not selected is deactivated.

When used as a complementary output, NPN or PNP outputs act in antiphase as the switch state changes.

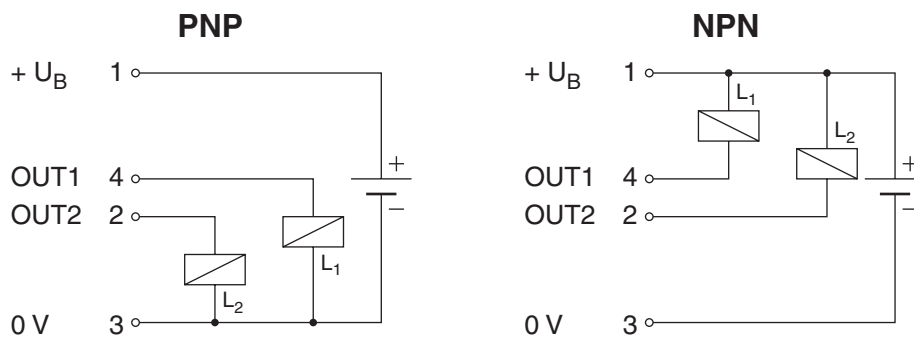

Figure 2 PNP/NPN load connection

7-3-2 Input circuits

The sensor inputs are realised in positive logic and detect a positive voltage level of more than 1 ms duration as a valid signal if the voltage level is between 10 V and the power supply voltage.

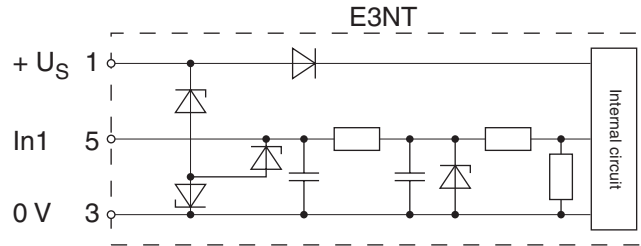

Figure 3 Input circuit input 1 (IN1 at pin 5)

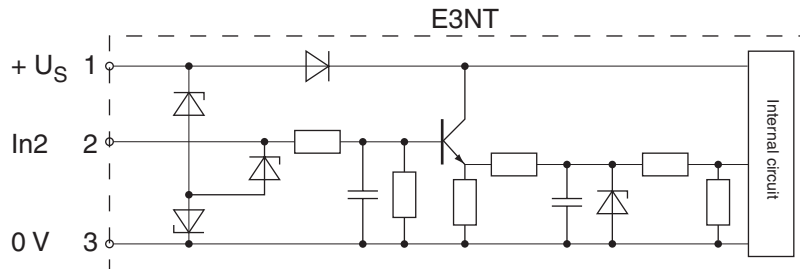

Figure 4 Input circuit input 2 (IN2 at pin 2)



Pin 2 can be set as input or output (factory default)

7-3-3 Connector pin assignments

The sensor is connected by means of a standard 5-pole M12 connector (see Figure 5 Connector pin assignments).

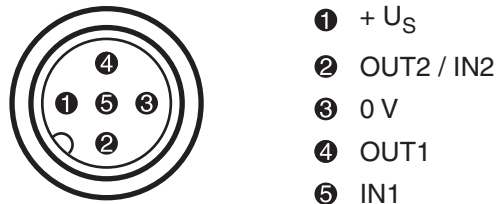

(View of connector pins on the sensor)

Figure 5 Connector pin assignments

7-4 Connection in line with EMC requirements

- In environments with interference levels, use cables with twisted-pair wires and/or shielded cables.
- When cables are introduced into an EMC control cabinet, guide the cable shield without interruption through the wall of the EMC control cabinet (e.g. via a cable conduit).
- Professionally connect the cable shield to the control cabinet housing (flat surface, conductive).
- Professionally connect wires of cables or free cable ends that are not used to the cable shield on both ends of the cable.
- If the control cabinet is connected by means of connectors, use connectors with a metal housing and a leading protective earth contact (in accordance with EN 60204-1) only.
- Conductively connect the cable shield to the connector housing.
- Professionally connect the mating connector to the control cabinet housing (flat surface, conductive).
- Route supply and signal leads in separate cable ducts.
- Route supply and signal leads as closely as possible to the equipotential bonding conductor.
- Do not route cable ducts in the proximity of strong electromagnetic interference sources such as electric motors or transformers.
- Suitable protective measures conforming to EN 60204-1 must be taken if the cable layout does not fully rule out the risk of lightning strikes.

SECTION 8

Setting into Operation

8-1	Safety notes	48
8-2	Switching on the operating voltage	48
8-3	Aligning the sensor	49
8-4	Setting the switching points	50
8-4-1	Teaching the switching points in the normal mode	50
8-4-2	Setting the sensor	50

8-1 Safety notes



The diffuse reflective sensors in the **E3NT** type series may only be used as described in these operating instructions. They may only be operated as part of a higher-level overall system, e.g. of a machine installation.



Diffuse reflective sensors in the **E3NT** type series must not be used as safety components within the scope of the EU machine guideline. Their use is not permitted in applications in which the safety of persons depends on functioning of the sensor!

8-2 Switching on the operating voltage

After the operating voltage has been switched on, the sensor runs a power-on reset with a self-test.

The sensor displays the current distance from the measured object if the self-test is successful.



$0--0$ is displayed if the sensor does not detect a measured object.



The flashing display ---- appears in the event of a short-circuit at the outputs.

The sensor continues normal functioning once the short-circuit at the outputs has been remedied.

8-3 Aligning the sensor

 Owing to the infrared emitted light, the light spot on the measured object is not visible.

Hence the sensor must be aligned relative to the optical axis.

The alignment marking on the top of the sensor can be used as a sighting line for the optical axis, thus simplifying alignment (*see Figure 1 Aligning the sensor*).

1. Position the measured object at the required position in front of the sensor.
2. Undo the securing screws.
3. Align the sensor's optical axis/alignment marking to the measured object.
4. Tighten the securing screws.
5. Check alignment once again.

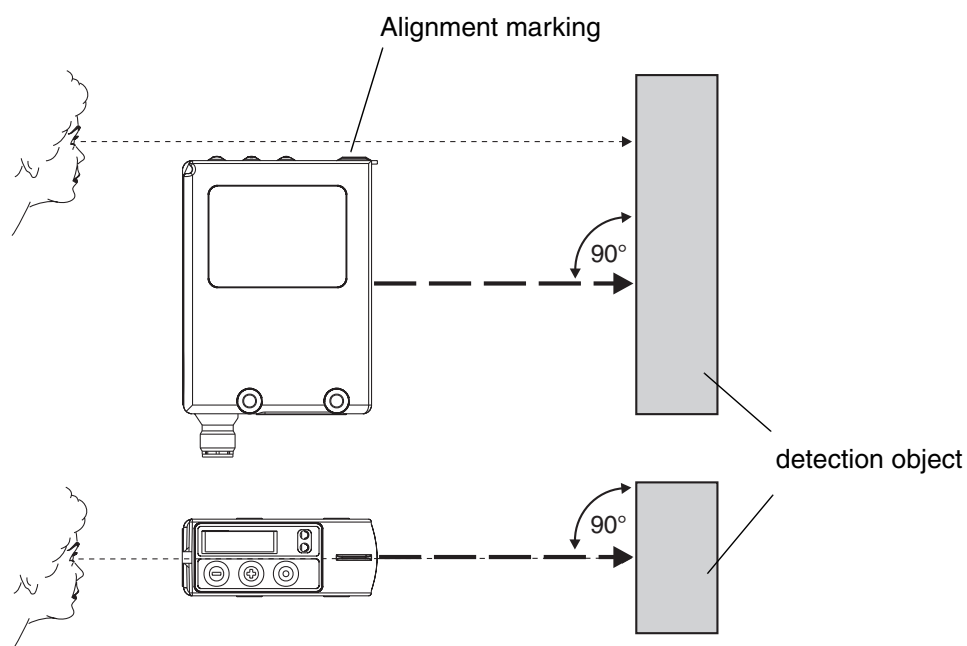

Figure 1 Aligning the sensor

8-4 Setting the switching points

The switching points can either be user set (Teach-in mode) with a measured object positioned at the corresponding distance or can be set using the setting input, for remote setting.

For each output of the sensor (up to two), up to two switching points can be user set.

Only one switching point is active in the foreground and background suppression modes.

For the 2-point window evaluation mode, two switching points must be set.

8-4-1 Teaching the switching points in the normal mode



The sensor is set at the factory for both outputs to **BGS**, light on.

1. Place the target object in front of the sensor at the desired position.
2. Teach the switching point for output 1:
 - Beginning with the \oplus key, press it simultaneously with the ENTER \bullet key. Threshold level is obtained and the output/LED is updated. Status LED is blinking.
 - Using the \oplus/\ominus keys an adjustment of the switching point is possible. The output/LED is updated immediately.
 - Pressing the ENTER \bullet key for more than 2 seconds or after 2 minutes without any activation of the keys, the sensor returns to normal operation. The status LED is turned off.
3. Teach the switching point for Output 2:
 - Beginning with the \ominus key, press it simultaneously with the ENTER \bullet key.

8-4-2 Setting the sensor

The sensor's parameters and the four possible switching points are set as described in Section 9-1 *Setting the sensor using the push buttons* or Section 9-2 *Setting the sensor with a PC*.

SECTION 9

Sensor Set-up

9-1	Setting the sensor using the push buttons	52
9-1-1	Display in the normal mode	52
9-1-2	Main menu structure	53
9-1-3	TEACH menu path	54
9-1-4	SET menu path	56
9-1-5	OPTIONS menu path	58
9-2	Setting the sensor with a PC	60

9-1 Setting the sensor using the push buttons

The sensor is set by means of three push buttons.

With these push buttons, the user navigates through the setting menus, through which all necessary sensor settings can be made.

- If no keys are pressed for 2 minutes during set-up, the sensor returns automatically to run mode.

9-1-1 Display in the normal mode

Depending on the user set-up, the sensor's display shows the following in the run mode:

- Status LED is turned off.
- Digital display:
The current distance from the sensor to the measured object in m.
- Bar display:
The current distance from the sensor to the measured object as a bar.

- The display shows $\bar{\bar{0}}$ if the sensor does not detect a measured object.

- The flashing display ---- appears in the event of a short-circuit on the outputs.
The sensor resumes normal functioning when a short-circuit on the outputs is eliminated.

9-1-2 Main menu structure

The following figure shows the structure of the main set-up menu.

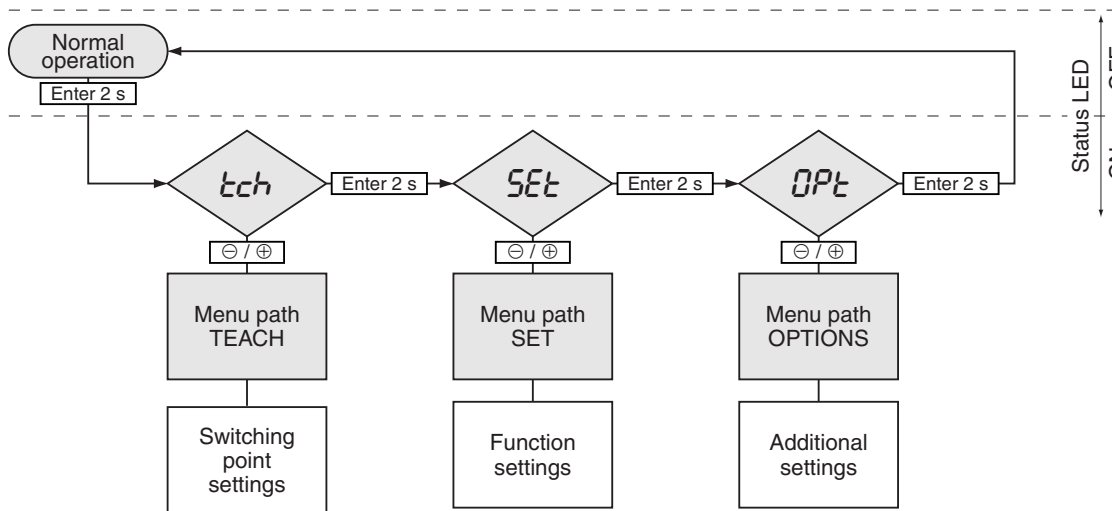





Figure 1 Structure of the main set-up menu

When the Enter ● key is pressed for 2 seconds, the sensor switches from the normal mode to the **TEACH** menu path. The sensor switches to each next menu path when the Enter ● key is repeatedly pressed for 2 seconds. In the menu paths, the required parameters can be selected by pressing the ⊖ and ⊕ keys.

-  To skip a menu path, you can also press the Enter ● key for 4 seconds.
-  Enter Press the Enter ● key < 1 second.
-  Enter 2 s Press the Enter ● key > 2 seconds.

9-1-3 TEACH menu path

The switching points of the outputs are taught or set-up in the **TEACH** menu path. The Status LED is on, blinking, during setpoint settings.

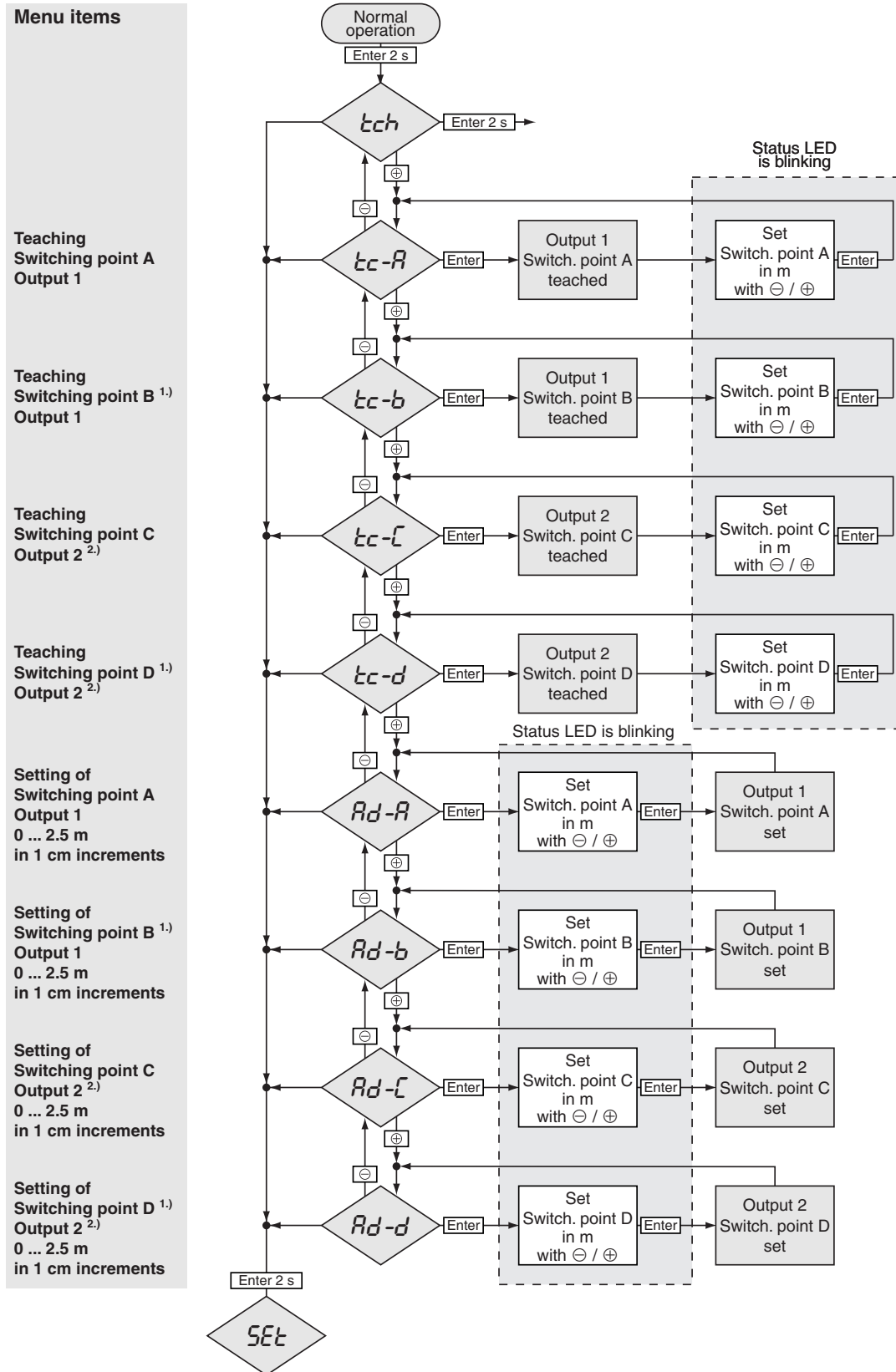

Figure 2 TEACH menu path

Remarks

1. In the 2-point window evaluation mode, two switching points (A/B and C/D) can be set for each output.
In the foreground and background suppression modes, only one switching point (A and C) can be set for each output. Then, only these switching points, A and C, can be set in the **TEACH** menu path. B and D switching points are not available.
2. If connector pin 2 is set as an input, only the switching points for Output 1 can be set.

9-1-4 SET menu path

All function parameters of the sensor are defined in the **SET** menu path.
The Status LED is on.

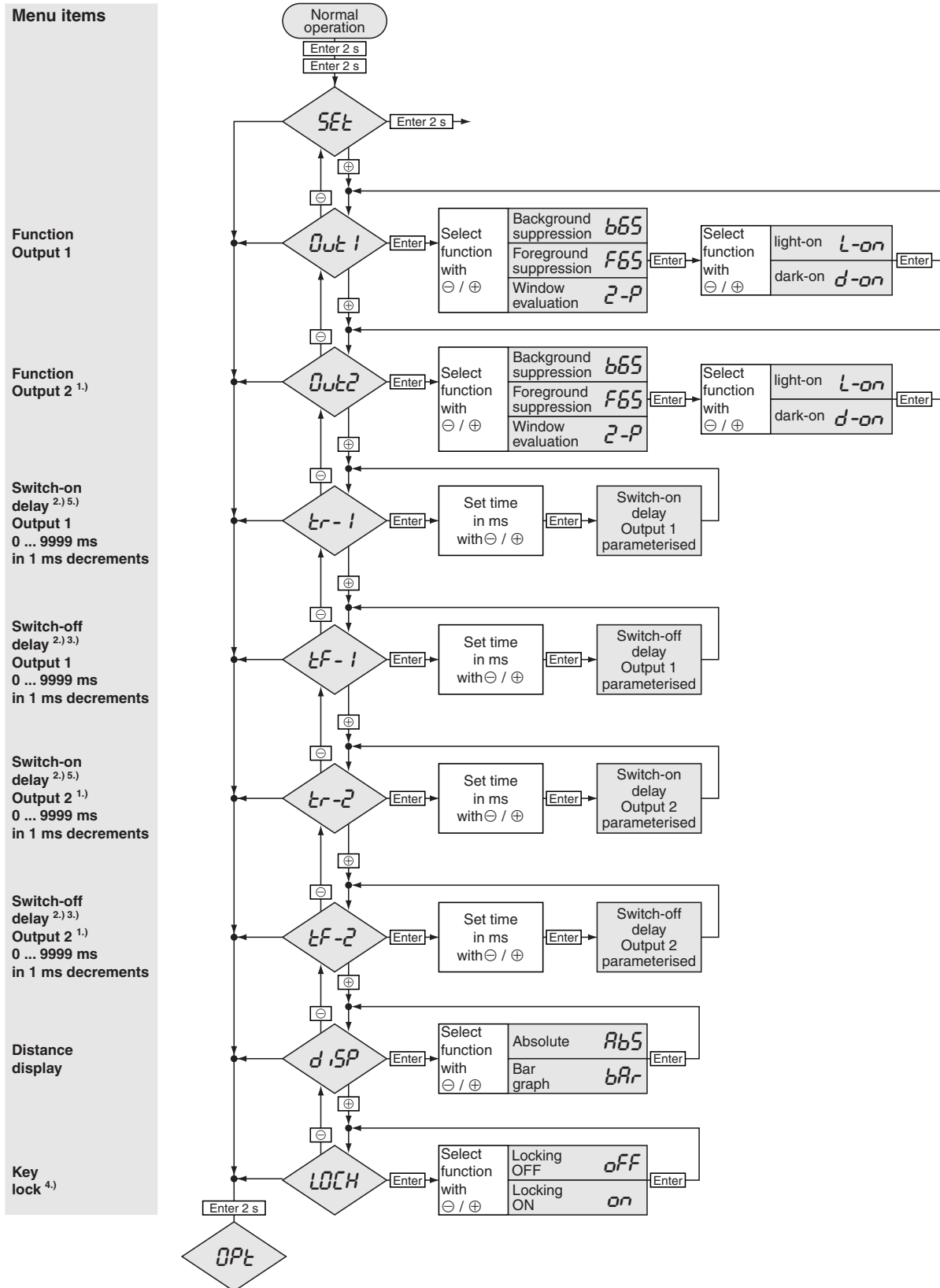

Figure 3 SET menu path

Remarks

1. If connector pin 2 is set as an input, the switch-on/off delay function can only be set for Output 1. A second switching output is not available.
2. If the switch-on/off delay is off in the **OPTIONS** menu path, the switch-on/off delay parameters do not appear in the **SET** menu path.
3. The outputs behave differently depending on the switch-off delay function that is set in the **OPTIONS** menu path.
4. The key lock becomes active again when no keys have been pressed for approx. 5 minutes.
The key lock can be temporarily cancelled by pressing the ⊖ and ⊕ keys for 4 seconds.
5. The On-delay-setting t_{r-1} or t_{r-2} are only available if the switch-on/off delay in the **OPTIONS** menu path is set to *on-1*.

9-1-5 OPTIONS menu path

All function options of the sensor are defined in the **OPTIONS** menu path.
The Status LED is on.

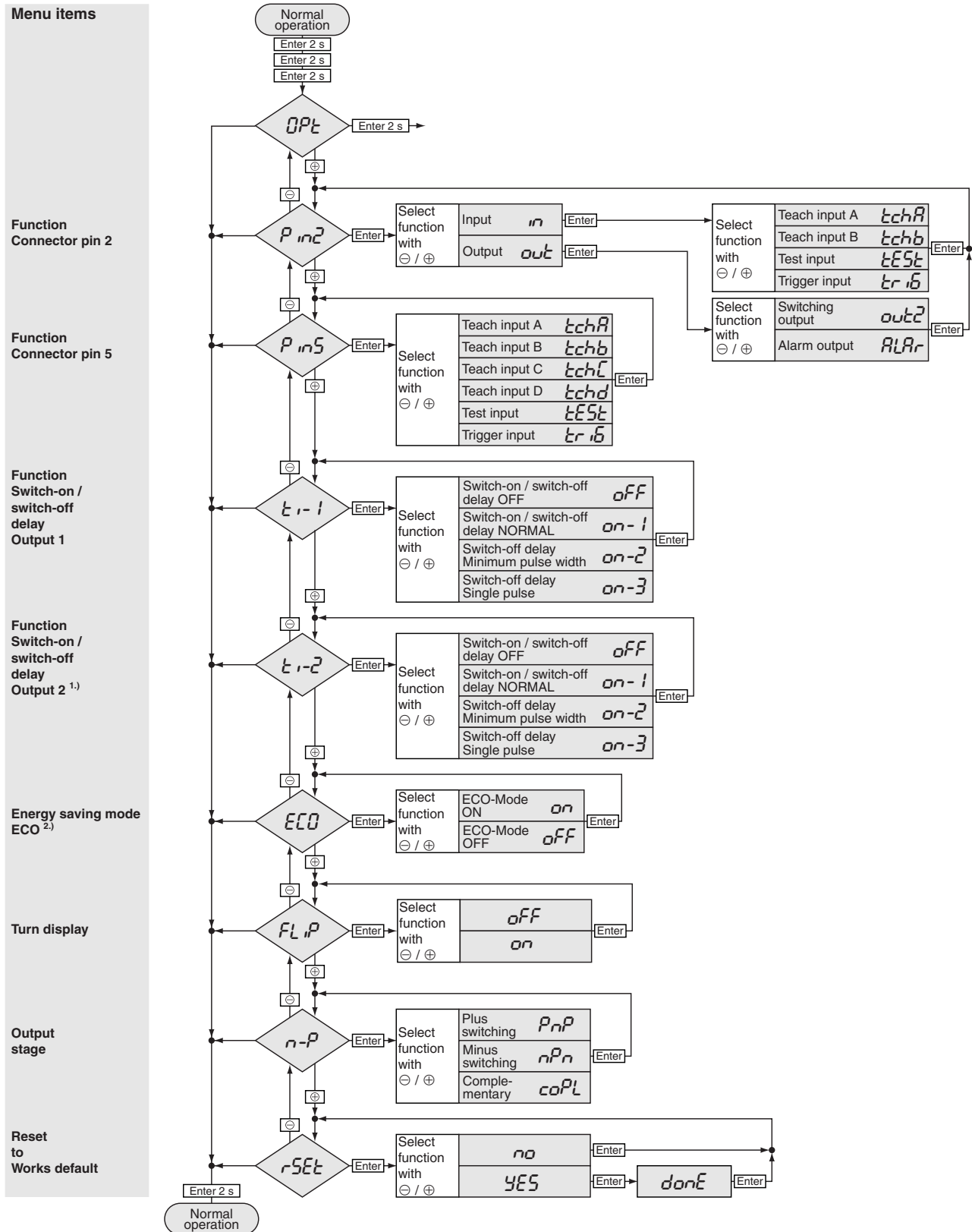

Figure 4 OPTIONS menu path

Remarks

1. If connector pin 2 is set as an input, the type of switch-on/off delay option can only be set for Output 1.
2. If the ECO energy saving mode is on, the display is switched off if no keys are pressed for about 5 minutes.
The display is switched on again when any key is pressed.

9-2 Setting the sensor with a PC

All parameters of the sensor can also be set with a PC and the **OMRON SensorSupportSoftware S³**.

The connection between the sensor and the PC is established via an optical data interface. The data interface is clipped onto the sensor and should be connected to a free COM port on the PC/laptop via the interface cable.

Data communication with the PC can be used for the following functions:

- Sensor set-up and configurations
- Real time readout
 - of the object distance
 - of switching states
 - of the stability
 - of the alarm outputs
- Monitoring and archiving the sensor data
- Updating the sensor firmware
 - A newer or customised version of the sensor's operating program can be transferred to the sensor.

 Power supply voltage must be 16 V min. for firmware update.

Refer to the separate operating instructions ABBO 0018 for further information on set-up with a PC and the **SensorSupportSoftware S³**.

SECTION 10 Maintenance and Repair

10-1 Maintenance	62
10-2 Repair	62

10-1 Maintenance



Assembly, electrical connection and maintenance may only be carried out by instructed, trained and authorised specialist personnel in accordance with applicable regulations, after de-energising the power supply and with the machine switched off.

The machine must be safeguarded against reactivation.

- ! Do not use any scratching or abrasive cleaning materials. The protective pane of the optical system might get damaged.

The sensor requires no maintenance.

- ! Remove dirt build up from the optical system and the display at regular intervals only with a soft, non abrasive fabric. Residual dirt may have influence on the switching point and display accuracy.

10-2 Repair

The sensor, the optical data interface and the alignment tool may only be repaired by the manufacturer.

Send in the sensor and the optical data interface tool to the supplier for repair along with a description of the fault.

SECTION 11
Accessories and Parts

11-1 Accessories and parts 64

11-1 Accessories and parts

Description	Article number
Universal mounting bracket	E39-EL1
Adapter bracket	E39-EL2
IR data interface, cable length 2 m	E3NT-AL232 2m
Straight cable socket, 5-pole, 2 m cable length	XS2F-D521-DG0-A
Straight cable socket, 5-pole, 5 m cable length	XS2F-D521-GG0-A
L-shaped cable socket, 5-pole 2 m cable length	XS2F-D522-DG0-A
L-shaped cable socket, 5-pole 5 m cable length	XS2F-D522-GG0-A

SECTION 12

Appendix

12-1 Error messages	66
12-2 Factory default settings	67

12-1 Error messages

The following error messages are shown on the sensor's display:

Display	Meaning
□--□	The sensor does not detect an object
---- (flashing)	Short-circuit at the output. The sensor continues normal functioning once the short-circuit at the outputs has been remedied.

12-2 Factory default settings

Parameter	Factory default settings
Mode of Output 1	Background suppression BGS
Mode of Output 2	Background suppression BGS
Output function of Output 1	Light-on
Output function of Output 2	Light-on
Output switching	PNP
Switch-on/off delay Outputs 1 and 2	OFF
Function of Connector pin 2	Output 2 (OUT 2)
Function of Connector pin 5	Teaching input (TEACH) for switching point A
Display	in m
Energy saving mode	OFF
Key lock	OFF