

CX-Server OPC Redundancy Quick Start Guide

Version 2.0

ã OMRON, 2008

All rights reserved. No part of this publication may be reproduced, stored in a retrieval system, or transmitted, in any form, or by any means, mechanical, electronic, photocopying, recording, or otherwise, without the prior written permission of OMRON.

All copyright and trademarks acknowledged.

No patent liability is assumed with respect to the use of the information contained herein. Moreover, because OMRON is constantly striving to improve its high-quality products, the information contained in this manual is subject to change without notice. Every precaution has been taken in the preparation of this manual. Nevertheless, OMRON assumes no responsibility for errors or omissions. Neither is any liability assumed for damages resulting from the use of the information contained in this publication.

Warning:	Failure to read and understand the information provided in this manual may result in personal injury or death, damage to the product, or product failure. Please read each chapter in its entirety and be sure you understand the information provided in the chapter and related chapters before attempting any of the procedures or operations given.
-----------------	---

Table of Contents

Introduction.....	4
Overview.....	5
Redundancy Levels.....	5
Fins Gateway Communications.....	5
Principles of Operation.....	5
Ethernet NIC's.....	7
Installation.....	7
Configuration.....	7
CX-Server OPC Configuration.....	8
CX-Server Project.....	8
Redundancy configuration.....	8
Device configuration.....	9
IP addresses and Subnet Masks.....	9
IP address table.....	9
PLC Programming.....	10
FB Configuration.....	10
OPC Client application.....	12
Device Names.....	12
OPC System Items.....	12
Data Read / Write.....	13
Appendix A System Diagram.....	14
Appendix B FB Configuration Example.....	15

Introduction

The purpose of this document is to act as a starter guide to creating a redundant system, with the use of CX-Server OPC and PLC function blocks (FBs). It is expected that this example would be used as a base for developing your own redundant solution using CX-Server OPC.

It is recommended to contact your local representative for further information on redundant solutions.

Overview

Redundancy Levels

CX-Server OPC and the supplied Redundancy Control function blocks (FB) support multiple levels of redundancy - device redundancy and optional network redundancy. This document assumes a full redundant system with dual networks is being configured.

Fins Gateway Communications

It is recommended to use CX-Server communications in a redundant environment. If you do choose to use Fins Gateway communications note that it does not support dual network redundancy.

Principles of Operation

In order to successfully design and configure a redundant solution it may be an advantage to understand some of the principles that are used in CX-Server OPC and the Redundancy Control function blocks. These most important of these are discussed in the following sections.

Device / Partner Relationship

A device in a redundant pair has equal status to it's partner. That is, there is no master/slave hierarchy but rather a peer-to-peer relationship. Each device communicates with it's partner (via Network Receive PLC instructions) in order to detect device and/or network failure. The Redundant Control FBs usually operate in stand-alone mode in which they have sole responsibility for deciding whether to become active or not, no input from CX-Server OPC is required.

FB / Server Relationship

CX-Server OPC communicates with the Redundancy Control FBs using Input and Output words. These are used to send commands to the device and for the device to report it's status. Refer to the section titled *FB Configuration* for the structure of these words.

CX-Server Device Relationship

In a redundant system, CX-Server OPC is connected to both devices in a redundant pair yet only a single "virtual" device is exposed to OPC clients. All OPC read requests are performed on the currently active device. To ensure data integrity and smooth changeovers, all OPC write requests are sent to both the currently active device and it's partner.

Switchover Behaviour

The following sections discuss switchover conditions and how the Redundancy Control FBs and CX-Server OPC react to them.

PLC / FB

In each device, an incrementing *Lifecycle Word* is read by its peer device in order to determine its status. If it is incrementing as expected the device is considered to be healthy. If the device is powered off, or enters program mode or fatal error, the *Lifecycle Word* is no longer incremented and so the device is considered to have failed. In this case the partner device will attempt to become active.

Note that if communications are restored and the lifecycle word of the originally active device is able to be read, the device will remain active (there is no device preference).

CX-Server OPC

The output words of all devices in the redundant system are read by CX-Server OPC. This status information is used to monitor the state of the system and to route OPC client requests to the correct (currently active) device.

If the connection to the currently active device is lost CX-Server OPC will respond according to the value of the OPC item **AutoSwitch**. If set, CX-Server OPC will make its own decision on which device is currently active. If it is not set, the **Active/InActive** flags will be used.

Network Preference

In a redundant system with dual networks the devices are monitored via both networks. In case of failure, the currently active network is changed to the secondary network. It is worth noting that CX-Server OPC will continue to monitor the status of the primary network and will switch back once communications have been restored.

Ethernet NIC's

Installation

Refer to the manufacturer's instructions for details on how to install the Ethernet NIC's.

Configuration

If dual network redundancy will be used, it is suggested that the NIC's are configured in the following way in order for Windows networking to route device communications through the correct network.

On the NIC's Internet Protocol (TCP/IP) Properties dialog, set the IP address and subnet masks like in the example below.

NIC Number	IP Address	Subnet Mask
1	10.0.10.50	255.255.255.0
2	10.0.11.50	255.255.255.0

The networks are separated by the use of different subnet identifiers in the third part of the IP address (10 or 11 in this example). It is important that the last part of the IP address is the same for every NIC, as it is used for the node number of the PC on the network(s).

CX-Server OPC Configuration

CX-Server Project

The CX-Server Project (.CDM file) is configured in the same way as in a non-redundant system; the method used for adding devices and points is no different. Note that for each redundant pair only one device (and its associated points), should be added to the project.

Redundancy configuration

The Redundancy Settings dialog is used to configure the redundant devices. In the example below there is a single redundant pair of CS1G-H PLC's which are configured to use dual network redundancy.

Node and Network Numbers

The node and network numbers entered here should match those configured in the PLC's Ethernet Bus Units.

PLC Status Location

This is the address of the Output Word of the redundancy control FB. The name of a point can also be used here.

Device	Redundancy Level	Redundancy On	Address	Network Number	Node	PLC Status Location
CJ1G-H - CPU42	1st Network		10.0.10.20	4	20	D0
	2nd Network	<input checked="" type="checkbox"/>	10.0.11.21	12	21	
Partner	1st Network	<input checked="" type="checkbox"/>	10.0.10.30	4	30	
	2nd Network	<input checked="" type="checkbox"/>	10.0.11.31	12	31	

Device configuration

The PLC's IO table and bus unit configuration (IP address and node number), should match what was entered in the Redundancy Settings dialog.

IP addresses and Subnet Masks

As with the Ethernet NIC's on the PC, subnet masks are used in combination with the IP addresses in order to split communications between the two networks.

For example, based on the Redundancy Settings dialog above, the IP address configuration of the device's Ethernet Bus Unit connected to the redundancy network would be: 10.0.11.21, and have a subnet mask of 255.255.255.0. It is important that the first 3 parts of the IP address matches the first 3 parts of the NIC's IP address.

IP address table

A number of network node / IP addresses are required to be added to each of the Ethernet Bus Units:

- The PC on which CX-Server OPC is running.
- The device's partner. This is required by the network send and receive function used in the Redundancy Control FB.
- It is also recommended to add the device's own network node and IP address in the list.

Note that in most cases the **combined** conversion option should be used.

Node	IP Address
021	010.000.011.021
031	010.000.011.031
050	010.000.011.050

PLC Programming

The supplied Redundancy Control FB can be dropped in to a CX-Programmer project to easily add redundancy control capabilities to a PLC program.

FB Configuration

There are a number of input and output parameters that require configuration. Some of them are standard to all FBs, others are used to set runtime options. The network and node number inputs variables are required by the device/partner communications functions.

Input Parameters

Many of these match the Ethernet Bus Unit settings for the devices.

EN

Standard FB input.

Enable

Included for use by future customisations of the Redundancy Control FB, to enable/disable internal parts.

InputWord

This must be the address of the PLC Status Location set in the Redundancy Settings dialog plus 4 words. It is used by CX-Server OPC and connected clients to send command messages to the device. See the section titled *OPC Output Items* for more details.

RecoveryDelay

This is used by the FB to avoid potential clashes between devices in a redundant pair. The value of this input must be different in a device and it's partner.

PartnerPrimaryNetwork

This is the network number of the partner's primary network.

PartnerPrimaryNode

This is the partner's node number on the primary network.

EnableSecondaryNetwork

In a dual network system this input should be set to **P_On**. Otherwise it should be set to **P_Off** in order to disable secondary network functionality.

PartnerSecondaryNetwork

This is the network number of the partner's secondary network.

PartnerSecondaryNode

This is the partner's node number on the secondary network.

DevicePrimaryNodeNum

This is the device's node number on the primary network.

Output Parameters

These are provided for use by the host PLC program and in the case of **OutputWord**, by CX-Server OPC.

ENO

Standard FB output.

OutputWord

This is the address of the PLC Status Location set in the Redundancy Settings dialog. It is used by CX-Server OPC and connected clients to monitor the device's redundancy related status.

RunPLC

Set to **On** if the Redundancy Control FB considers that the PLC should be active.

PartnerConnected_Primary

Set to **On** if the Redundancy Control FB is able to communicate with the partner device via the primary network.

PartnerConnected_Secondary

Set to **On** if the Redundancy Control FB is able to communicate with the partner device via the secondary network.

Internal Variables

The Specified Address of the internal variable **SourceData**, must match the PLC Status Location entered in the Redundancy Settings dialog.

Program Differences

It is worth noting that the PLC programs in a device and it's partner are identical. The only exception to this is the input variables of the Redundancy Control FB (eg **PartnerPrimaryNetwork**).

Stand Alone Operation

The Redundancy Control function blocks are solely responsible for monitoring the partner devices for failure and deciding to switch between active and inactive states. CX-Server OPC can send commands to the devices (via the **InputWord** parameter) but for purely monitoring a redundant system, this is not required.

OPC Client application

Device Names

The names of the devices exposed to an OPC client follow a simple convention; suffixes are appended to the device name set in the CDM file which refer to the virtual device's network redundancy level in addition to it's device/partner status.

With a CDM file containing a single device called *MyPLC* the following devices would be exposed to an OPC client in a redundant system with dual networks.

Name	Description
MyPLC	Configured device, first network
MyPLC_2	Configured device, second network
MyPLC_P	Partner device first network
MyPLC_P_2	Partner device, second network

OPC System Items

A number of built-in system items are exposed to OPC clients which can be used to monitor the status of any device in addition to the system as a whole. Some of the most useful ones are discussed in the following sections. Refer to the CX-Server OPC manual for a complete list of items including further descriptions.

OPC Input Items

These OPC items expose the output word of the Redundancy Control FB and can be used to monitor the state of any device in a redundant system. For example, the **Active / InActive** can be used to determine which device is currently the active device.

OPC Output Items

These OPC items expose the input word of the Redundancy Control FB and can be used to send commands to a device in a redundant system.

Note that the Redundancy Control FB will only respond to these commands if the **UseFBInput** flag is set. This is a Boolean OPC item which can be written to in the usual way.

Changing the Active Device

There are three OPC output items that allow OPC clients to decide which device in a redundant pair is active. Two of these items are quite simple; **MakeActive** causes the device to be active, **MakeInactive** causes the device to be inactive. Setting **ForceRunPLC** causes the device to be active and stay in this state until it is reset.

FB Generated Alarms

The OPC output items include two alarm items; **ProgChangeAlm** (the device's program has changed) and **PartnerFailAlm** (the device has lost peer-to-peer communications with its partner). These alarms can be acknowledged by setting the corresponding OPC input flags; **AcceptPCAlarm** and **AcceptPFAlarm**.

Monitoring Device Status

A number of the system points can be used to get a complete picture of the state of the devices in a redundant system.

Status and **StatusText** indicate the current status of a device in OPC hexadecimal and an easy to read textual representation. For example, a **Status** of 0x1c would co-respond to a **StatusText** of *OPC Quality Out of Service*. The value of the **OKConnections** OPC item co-responds to number of currently valid connections to a device (e.g. in a system with both device redundancy and network redundancy this value will normally be 4).

FatalError is a Boolean OPC item and indicates that the device has gone into a fatal error condition.

The **AutoSwitch** OPC item affects how CX-Server OPC treats a communications loss. If set, it will treat the device as inactive regardless of the **Active** and **InActive** flags. If it is not set, the redundancy is under full FB control.

Data Read / Write

In a redundant system an OPC client sees a single connected device, which in fact consists of two physical devices which are effectively duplicates of each other in terms of programs, data, I/O connectivity etc. All OPC read requests use the current active device. All OPC write requests are sent to both the active and inactive devices. This is to ensure that, in the event of a switchover, the newly active device has the same data as its partner.

Write Loading

It is worth noting that due to this single-read, double-write operation, any processing requirements and network traffic associated with OPC write requests are effectively doubled, by the introduction of partner devices and redundant systems.

Appendix A System Diagram

A diagrammatic view of the redundant system used as an example in this document.

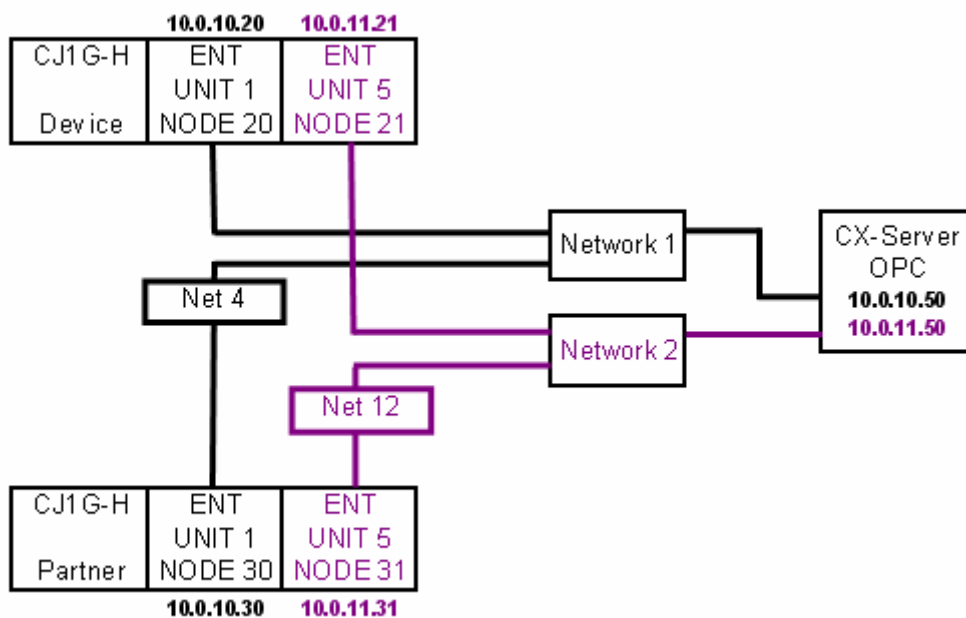

Appendix B FB Configuration Example

The table below lists example input/output values for the Redundancy Control FB of the partner device shown in the Redundancy Settings dialog screenshot.

Parameter Name	Value
EN	P_On
Enable	P_On
InputWord	D4
RecoveryDelay	#30
PartnerPrimaryNetwork	&4
PartnerPrimaryNode	&20
EnableSecondaryNetwork	P_On
PartnerSecondaryNetwork	&12
PartnerSecondaryNode	&21
DevicePrimaryNodeNum	&30
ENO	W3.00
OutputWord	D0
RunPLC	W0.00
PartnerConnected_Primary	W1.00
PartnerConnected_Secondary	W2.00